



Advanced Course

Appalachian Underground Corrosion Short Course
West Virginia University
Morgantown, West Virginia

Copyright © 2011

**APPALACHIAN UNDERGROUND CORROSION SHORT COURSE
ADVANCED COURSE**

CHAPTER 1 - PIPE-TO-SOIL POTENTIAL SURVEYS AND ANALYSIS	1-1
INTRODUCTION	1-1
CORROSION MECHANISMS	1-1
PIPE-TO-SOIL POTENTIAL MEASUREMENT	1-2
TYPES OF POTENTIAL SURVEYS	1-2
SINGLE ELECTRODE METHOD	1-3
TWO ELECTRODE METHOD	1-3
SIDE-DRAIN MEASUREMENTS	1-4
ANALYZING PIPE-TO-SOIL POTENTIAL DATA	1-4
PIPE-TO-SOIL POTENTIAL SURVEYS AND ANALYSIS	1-5
INTERPRETATION OF POTENTIALS UNDER NON-STRAY CURRENT CONDITIONS	1-6
COATED CROSS-COUNTRY PIPELINE WITHOUT CATHODIC PROTECTION	1-7
GAS SERVICE LINE	1-7
GROUNDING SYSTEM	1-8
STEEL GAS AND WATER LINES	1-8
CRITERIA FOR CATHODIC PROTECTION	1-9
WHICH CRITERION?	1-10
POTENTIAL MEASUREMENT OF -850 mV TO A Cu/CuSO ₄ REFERENCE ELECTRODE WITH CATHODIC PROTECTION APPLIED	1-10
POLARIZED POTENTIAL OF -850 mV MEASURED TO A Cu/CuSO ₄ REFERENCE ELECTRODE	1-11

100 MILLIVOLT POLARIZATION CRITERION	1-12
CRITERIA FOR SPECIAL CONDITIONS - NET PROTECTIVE CURRENT CRITERION	1-13
OTHER CRITERIA	1-14
E LOG I CURVE CRITERION	1-14
300 MILLIVOLT POTENTIAL SHIFT CRITERION	1-15
USE OF CRITERIA	1-16
CHAPTER 2 - EVALUATION OF UNDERGROUND COATINGS USING ABOVEGROUND TECHNIQUES	2-1
INTRODUCTION	2-1
SURVEY SEQUENCE	2-1
REFERENCED PROCEDURES	2-1
DEFINITIONS	2-2
SAFETY CONSIDERATIONS	2-3
PIPELINE LOCATING	2-3
DIRECT CURRENT VOLTAGE GRADIENT SURVEYS (DCVG)	2-4
ALTERNATING CURRENT VOLTAGE GRADIENT SURVEYS (ACVG)	2-7
CLOSE-INTERVAL SURVEYS (CIS)	2-8
AC CURRENT ATTENUATION SURVEYS (ELECTROMAGNETIC)	2-10
SUMMARY	2-11
CHAPTER 3 - MATERIALS FOR CATHODIC PROTECTION	3-1
INTRODUCTION	3-1
CONSIDERATIONS FOR ALL MATERIALS	3-1
GALVANIC ANODES	3-1

Prepared Backfill and Packaging	3-2
Wire and Cable Attachment	3-3
Magnesium Alloys	3-3
Zinc Alloys	3-4
Aluminum Alloys	3-4
IMPRESSED CURRENT CATHODIC PROTECTION SYSTEMS	3-5
Specifications	3-5
High Silicon Cast Iron	3-6
Graphite Anodes	3-7
Aluminum Anodes	3-7
Lead Silver Anodes	3-7
Magnetite Anodes	3-8
Mixed Metal Oxide Anodes	3-8
Platinum Anodes	3-9
Polymer Conductive Anodes	3-10
Scrap Steel Anodes	3-10
Backfill for Impressed Current Anodes	3-10
WIRE AND CABLE	3-11
CABLE CONNECTIONS AND SPLICES	3-11
SPLICE ENCAPSULATION	3-11
POWER SUPPLIES	3-12
JUNCTION AND RESISTOR BOXES	3-13
PERMANENTLY INSTALLED REFERENCE ELECTRODES	3-13
TEST STATIONS	3-14

FLANGE ISOLATORS AND DIELECTRIC UNIONS	3-15
MONOLITHIC WELD IN ISOLATORS	3-15
CASING ISOLATORS AND END SEALS	3-16
CONCLUSIONS	3-16
CHAPTER 4 - DYNAMIC STRAY CURRENT ANALYSIS	4-1
INTRODUCTION	4-1
STRAY CURRENTS	4-1
THE EARTH AS A CONDUCTOR	4-1
POTENTIAL GRADIENTS IN THE EARTH	4-2
DETECTION OF DYNAMIC STRAY CURRENTS	4-2
Interpreting Beta Curves	4-3
Determining the Point of Maximum Exposure	4-4
METHODS OF MITIGATING THE EFFECTS OF DYNAMIC STRAY CURRENT	4-4
Controlling Stray Currents at the Source	4-4
Mitigation (Drainage) Bonds and Reverse Current Switches	4-4
Sizing the Mitigation (Drain) Bond	4-5
Use of Sacrificial Anodes	4-8
Use of Impressed Current Systems	4-8
STRAY CURRENT FROM ALTERNATING CURRENT (AC) SOURCES	4-8
CONCLUSIONS	4-9
REFERENCES	4-9
CHAPTER 5 - DESIGN OF IMPRESSED CURRENT CATHODIC PROTECTION ..	5-1
INTRODUCTION	5-1

REVIEW OF IMPRESSED CURRENT SYSTEM FUNDAMENTALS	5-1
Definition	5-1
Theory of Operation	5-1
Application	5-2
Advantages and Disadvantages	5-2
INFORMATION USEFUL FOR DESIGN OF AN IMPRESSED CURRENT CATHODIC PROTECTION SYSTEM	5-2
DESIGN OF AN IMPRESSED CURRENT ANODE BED	5-3
General	5-3
Selecting an Anode Bed Site	5-3
Selecting Anode Bed Type Based on Site Selection	5-4
Distributed Anode Bed	5-4
Remote Anode Bed	5-4
Deep Anode Bed	5-4
Hybrid Anode Bed	5-5
Tests Required for Anode Bed Design	5-5
DESIGN CALCULATIONS	5-7
Existing Structures	5-7
Current Requirement	5-7
Determining the Number of Anodes	5-9
Calculating the Anode Resistance-to-Earth	5-10
Calculating Total Circuit Resistance	5-12
Sizing the Rectifier or DC Power Supply	5-13
DESIGN OF DISTRIBUTED ANODE BED	5-14
DESIGN OF DEEP ANODE BED	5-15

CONCLUSIONS	5-16
CHAPTER 6 - DESIGN OF GALVANIC ANODE CATHODIC PROTECTION	6-1
INTRODUCTION	6-1
GALVANIC ANODE APPLICATION	6-1
General Uses	6-1
Specific Uses	6-1
GALVANIC ANODE CATHODIC PROTECTION DESIGN PARAMETERS	6-1
Galvanic Anode Selection	6-1
Anode Current Efficiency	6-2
Current Requirements	6-2
Electrolyte Resistivity	6-2
Total Circuit Resistance	6-2
Anode Bed Resistance	6-2
Resistance of Interconnecting Cables	6-3
Cathode-to-Earth Resistance	6-3
Anode Life	6-3
GALVANIC ANODE DESIGN CALCULATIONS	6-4
Simplified Calculations	6-6
SPECIFICATION AND MAINTENANCE OF GALVANIC ANODE INSTALLATIONS	6-7
CONCLUSIONS	6-8
CHAPTER 7 - MIC INSPECTION AND TESTING	
INTRODUCTION	7-1

SITE SELECTION	7-1
COATING INSPECTION	7-2
MIC AND DEPOSIT SAMPLING	7-2
MIC SAMPLING AND TESTING	7-2
SUPPORTING ANALYSES	7-3
METALLURGICAL INSPECTION	7-4

May 25, 2011 Revision

To submit comments, corrections, etc. for this text, please email: curriculum@aucsc.com

CHAPTER 1

PIPE-TO-SOIL POTENTIAL SURVEYS AND ANALYSIS

INTRODUCTION

The objective of this chapter is to present the most important corrosion control measurement, the pipe-to-soil potential measurement, and the various methods that can be used to make this measurement.

This chapter will also show how pipe-to-soil potential data can be used to identify and evaluate corrosion problems as well as assist in determining the effectiveness of a cathodic protection system.

Also included in this chapter is a discussion of the criteria for cathodic protection and the applications for each.

All pipe-to-soil potential values given in this chapter will be with respect to a saturated copper/copper sulfate reference electrode (CSE). Unless otherwise noted, or in an example where lateral measurements are being taken, all potential values given will be with the reference electrode placed at grade directly over the structure being tested. Keep in mind that the pipeline potential is referenced to the electrode location not to the structure connection point. See Figure 1-1 for a typical pipe-to-soil potential measurement test setup.

Because the normal pipe-to-soil potential of steel measured with respect to a CSE is almost always negative, this chapter will present examples using potentials with negative values. Therefore, negative potentials with greater absolute values are “more negative”. For example, a potential measurement of -600 mV is “more negative” than a measurement of -400 mV.

CORROSION MECHANISMS

The corrosion of an underground or submerged metallic structure is electrochemical in nature. There are basically two different mechanisms which are responsible for this corrosion and these are termed electrolytic corrosion and galvanic corrosion.

Electrolytic corrosion, often called stray current corrosion, results from currents which are introduced into the ground from neighboring sources of direct current (DC) such as electric railways, DC powered machinery, and foreign cathodic protection systems.

Galvanic corrosion is the result of the natural electrochemical process that takes place on a buried metallic structure due to potential differences which exist between points on the same structure due to different surfaces, dissimilar electrolytes, differential aeration or the coupling of dissimilar metals. This type of corrosion is often classified into categories such as local action, long line activity, and bimetallic activity.

Both of these corrosion mechanisms can be detected and evaluated through the proper use of the pipe-to-soil potential measurement.

Pipe-to-soil potential measurements can indicate whether a structure is subject to dynamic or fluctuating stray current corrosion. Because stray currents that come from DC powered railways or machinery are rarely if ever constant, fluctuations in potential on an effected structure will indicate the presence of this type of stray current. In order to determine the degree of potential fluctuation and the

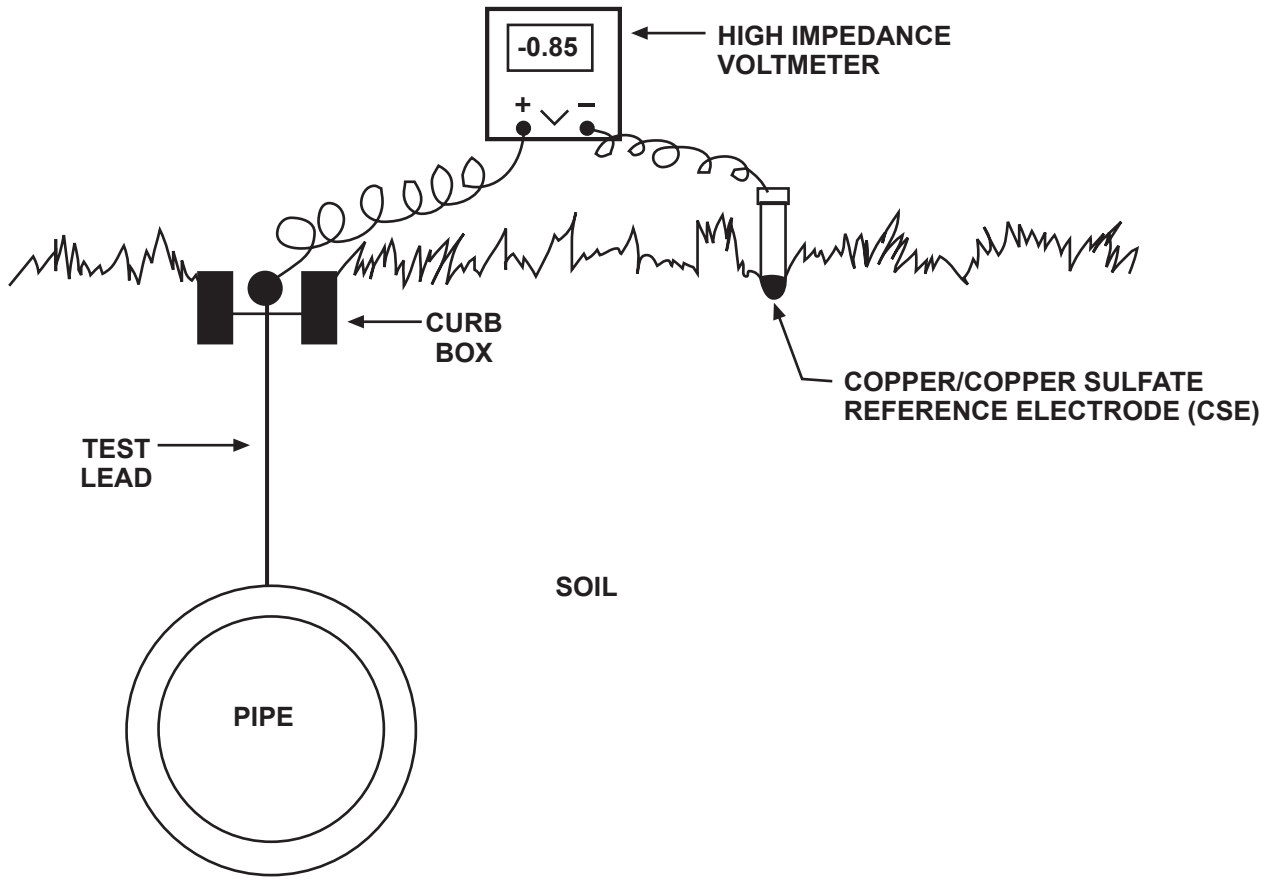

PIPE-TO-SOIL POTENTIAL MEASUREMENT

FIGURE 1-1

amount of time that the structure is effected, DC voltage recording instruments can be employed.

Non-fluctuating stray current or static stray current is not as readily apparent as the dynamic type. In this case, the interference effect from a foreign cathodic protection system will usually remain constant and unless there is existing historical potential data, or one has the opportunity to participate in cooperative interference testing, this type of stray current interference may not be immediately detected. However, there are potential measurement techniques that can detect this type of stray current interference such as lateral potential surveys, which will be discussed later in this chapter.

PIPE-TO-SOIL POTENTIAL MEASUREMENT

Before the various test methods and evaluation processes are discussed, a review of the pipe-to-soil potential measurement is required. This measurement must be obtained using a high impedance voltmeter, a calibrated reference electrode, an electrolyte present over the pipe where the reference electrode can be placed, and a method by which to contact the structure under test. A high impedance voltmeter is required in order to obtain the most accurate potential reading. The reference electrode should be filled with distilled water (or electrode gel solution) after the copper rod has been cleaned with a nonmetallic abrasive and copper sulfate crystals have been added. The electrolyte for the placement of the reference electrode should be soil or water. Concrete and asphalt should be avoided. The connection to the structure under test can be a valve, riser pipe, test station, etc., any point electrically continuous with that portion of pipe being evaluated.

The preferred polarity convention has the reference electrode connected to the negative terminal of the voltmeter and the structure connected to the positive terminal. This polarity connection will normally result in a negative value. It is important to note that consistency is

critical when recording these potential values whether it be as a negative value or a positive value. The methods and instrumentation employed for this testing are critical in order to provide meaningful data that can be properly evaluated.

TYPES OF POTENTIAL SURVEYS

A normal survey of a pipeline system in order to obtain either static or native potential values or to ascertain the effectiveness of an existing cathodic protection system might consist of measuring pipe-to-soil potentials at all available test locations such as those described previously. However, there are occasions when it is necessary to obtain additional potential measurements between test points. This is accomplished by placing the reference electrode at regular intervals over the pipeline and measuring potentials at each reference location. The spacing of the intervals will depend on the type of survey being performed and the type of detail required. This type of survey will indicate the anodic locations along an unprotected structure which will be those areas with the most negative potentials. However, these more negative potentials may also correspond to a stray current "pickup" area. In the case of a pipeline under cathodic protection, this type of survey will reveal those locations where protection might not be achieved based on an evaluation of the potential values.

In order to insure the accuracy of an over-the-line potential survey, the pipeline should be first electronically located and staked out by the survey crew. This will help to ensure that the potential measurements are taken directly over the pipeline. Just as it is important to use the proper equipment as explained earlier, it is equally important that the reference electrode be placed in clean soil devoid of rocks, weeds, or grass which could effect the electrode contact resistance and thereby effect the accuracy of the measurement. In other words, make sure to establish good cell contact with the electrolyte.

It is also important to insure that the pipeline you are testing is electrically continuous for the length of pipe to be surveyed.

Detailed over-the-line potential surveys can be conducted using various methods and test equipment which will yield a variety of useful information. The following is a description of some commonly used survey methods.

SINGLE ELECTRODE METHOD

The first method to be discussed is the single electrode survey, see Figure 1-2. This survey utilizes one CSE, a high impedance voltmeter, and a reel of test wire. An additional requirement is a point of electrical contact to the structure being tested.

There are two ways to perform this particular survey. In the first procedure, the pipeline is contacted through a test lead or other suitable connection point which is connected to a test reel. The test reel is connected to the positive terminal of a voltmeter and the testing personnel measure potentials along the pipeline at prescribed intervals, carrying and moving both the voltmeter and the reference electrode together. Once again, the reference electrode is connected to the negative terminal of the voltmeter. This polarity convention can be altered as long as the convention is consistent and the test personnel are aware of the polarity of the measured pipe-to-soil potential.

In the second procedure, the test reel is connected to the reference electrode and the voltmeter is left at the point of connection to the pipeline. This method requires two testing personnel with one at the voltmeter recording the data and the other individual moving the reference electrode along the pipeline and contacting the soil at set intervals. In cases where a long section of pipeline is to be tested or where the terrain is such that visual contact cannot be maintained, some type of communications equipment is needed in order to coordinate the timing of the readings.

It should be noted that potential readings taken

using the one electrode method may be affected by voltage drop in the pipeline and measuring circuit or by stray current interference.

The data can be recorded manually on field data sheets or electronically using a recording voltmeter or datalogger.

Figure 1-3 shows the basic components and hookups for recording the data electronically using a computerized system. In this case, the voltage measuring and datalogging equipment can be carried in a compact backpack arrangement by the operator. The operator carries one or two reference electrodes, which may be affixed to the bottom of extension rod(s), which are then "walked" forward at some specific interval, usually 2½ to 3 feet. Potential measurements are electronically recorded and stored by the instrument. The long test lead back to the connection to the pipeline at the survey starting point can be a one-time-use disposable light gauge wire. During the course of the potential survey the operator is able to electronically note distances, terrain features and landmarks as well as other pertinent information.

The electronically collected data can then be processed by a personal computer in the field or at the office. The computers can be programmed to produce a potential profile complete with identifying notes for the pipeline section surveyed. Some programs will allow for the plotting of previous survey data for comparison.

TWO ELECTRODE METHOD

Another potential survey method to be discussed is the two-electrode survey illustrated in Figure 1-4. This survey uses two CSEs, a high impedance voltmeter, and a pair of test leads. These leads can be cut equal to the span of the preselected survey distance. The survey is conducted by first measuring and recording the pipe-to-soil potential with respect to reference electrode "A" as shown in Figure 1-4. Reference electrode "B" is then placed

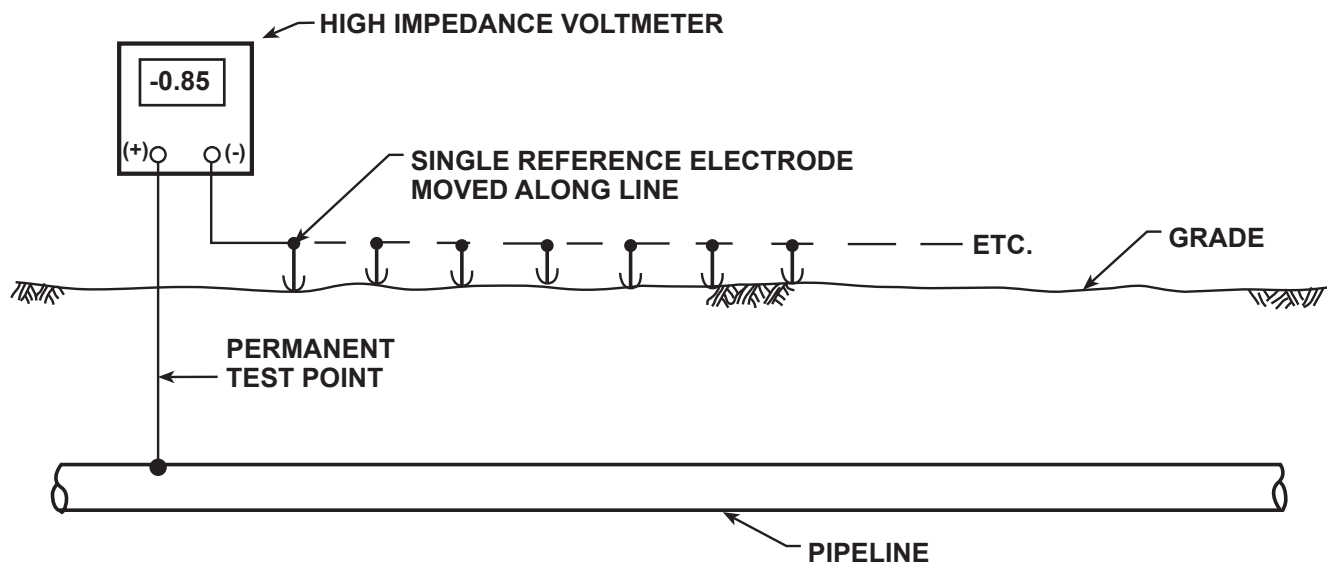

SINGLE ELECTRODE POTENTIAL SURVEY

FIGURE 1-2

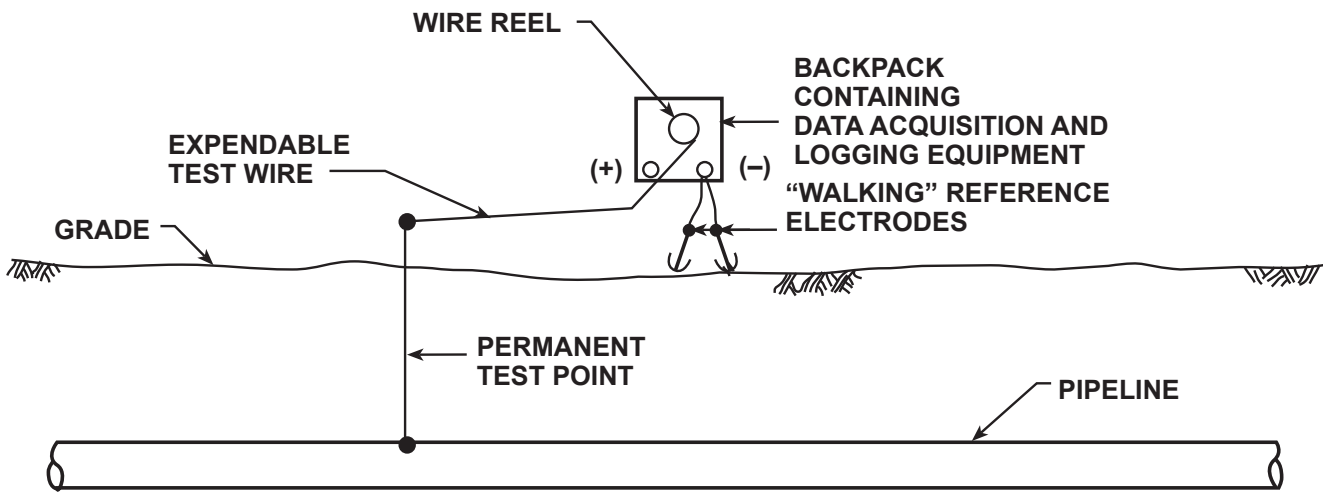

TYPICAL COMPUTERIZED POTENTIAL SURVEY

FIGURE 1-3

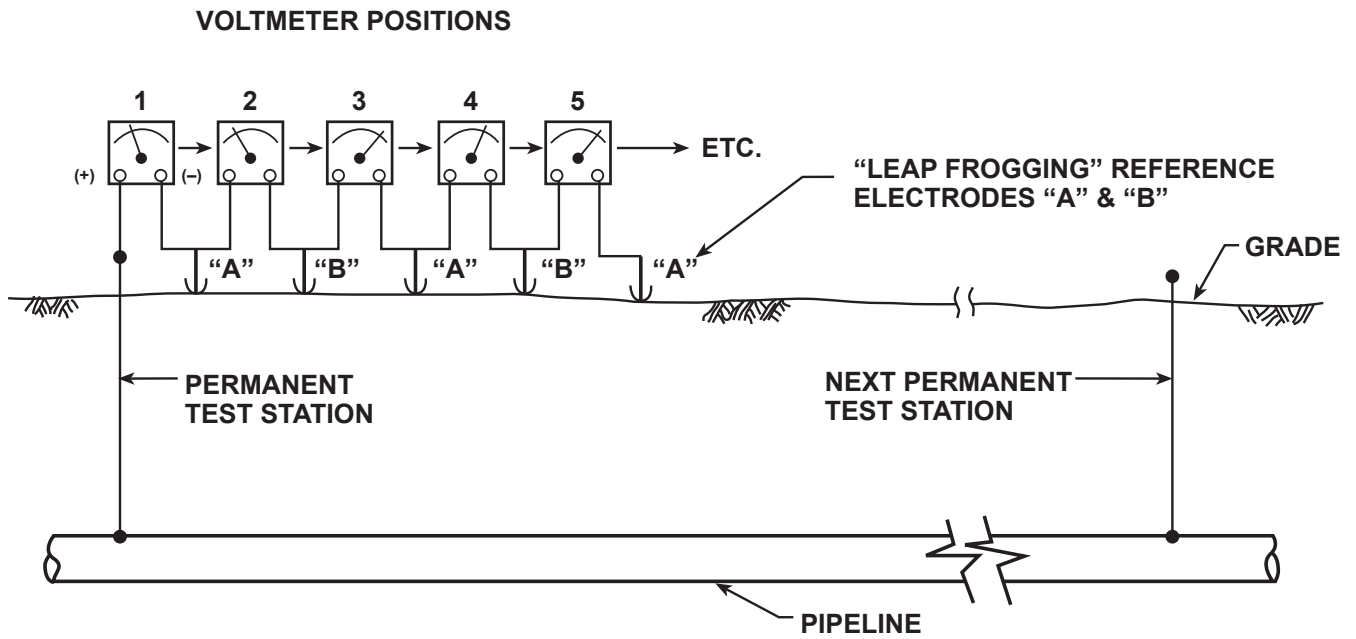

FIGURE 1-4

along and directly over the pipeline at some preselected survey interval from reference electrode "A". The potential difference between the two electrodes is then measured and numerically added or subtracted from the previous reading in accordance with the measured polarity of the forward electrode ("B" in this case). This "leap frogging" of the two electrodes is continued until the next permanent test station is reached or any other location where the pipeline can be electrically contacted.

At this juncture, the cumulative potential up to this point is compared to the actual potential measured to a CSE at this second permanent test station and adjusted as necessary. The survey then continues following the above described procedure to the next contact point.

The data should be recorded in a permanent log. See Table 1-1 for a typical recording format.

The two electrode method works well. However, it requires that a great deal of care be taken in recording the data. An error made in the calculating of potentials or the noting of polarity at any given point will cause all subsequent calculated potentials to be erroneous. In the case of an error, the calculated pipe-to-electrode potential will not correspond to the potential measured at the next contact point.

Note however, that even if there are no data errors, a discrepancy could still exist between the last calculated pipe-to-soil potential and the actual measured potential at the contact point. One possible reason is that any current flowing on the pipe will cause a voltage drop across the pipeline between the two test points which could account for the difference. Another reason for a difference could be the effect of stray current activity on the pipeline potential.

SIDE-DRAIN MEASUREMENTS

If more detailed information is desired, another method known as side-drain measurements can often be used to troubleshoot problem

areas. Side-drain measurements are conducted utilizing two CSEs and a high impedance voltmeter, as shown in Figure 1-5. The first electrode is placed directly above the pipe, in contact with the soil. The second electrode is placed in contact with the soil at a 90° angle to the pipe at a distance approximately equal to 2½ times the pipe depth. During testing, the electrode placed directly above the pipe should be connected to the positive terminal of the voltmeter and the other electrode to the negative terminal. Positive side-drain readings indicate that current is being discharged from the pipe at this point, making it an anodic area. Negative side-drain readings normally indicate that current is flowing towards or onto the pipe at this point, making it a cathodic area. The side-drain measurements should be taken typically at no more than 5-foot intervals. Tests must be made on both sides of the pipe, until the extent of the problem section has been determined.

This technique should be used with caution. Under certain conditions, a relatively strong localized anodic cell could exist on the bottom of the pipe with the top of the pipe serving as a cathode and negative side-drain readings could be measured while severe corrosion is actually occurring on the bottom of the pipe at this location.

ANALYZING PIPE-TO-SOIL POTENTIAL DATA

Upon completion of the pipe-to-soil potential survey, the compiled data is normally plotted on a graph to facilitate interpretation. Potential (V or mV to CSE) is plotted versus distance (ft).

On cathodically protected pipelines, the pipe-to-soil potential survey is used to determine if adequate levels of protection are being provided to all areas of the pipeline. Adequate levels of protection are often based on the -850 mV ("instant off," or "on" corrected for voltage drops) versus a CSE. However, the 100 mV criterion could be used if a static potential profile of the line is available.

TABLE 1-1

**Typical Data Record For Two Electrode Potential Survey
Conducted on a Cathodically Protected Pipeline**

A	B	C	D	Comments
1	--	-	-0.860 ⁽¹⁾	--
2	0.035	+	-0.895	--
3	0.021	+	-0.916	--
4	0.065	-	-0.851	--
5	0.092	-	-0.759	Unprotected Area
6	0.045	+	-0.804	Unprotected Area
7	0.063	+	-0.867	--
8	0.011	+	-0.878	--
9	0.020	-	-0.858	--
10	0.032	+	-0.890	--

Where: A = position or pipeline section
B = potential drop from electrode at last position (volts)
C = polarity of forward electrode
D = pipe to copper sulfate electrode (volts)

Note: (1) Initial value measured via direct pipeline contact at Position 1

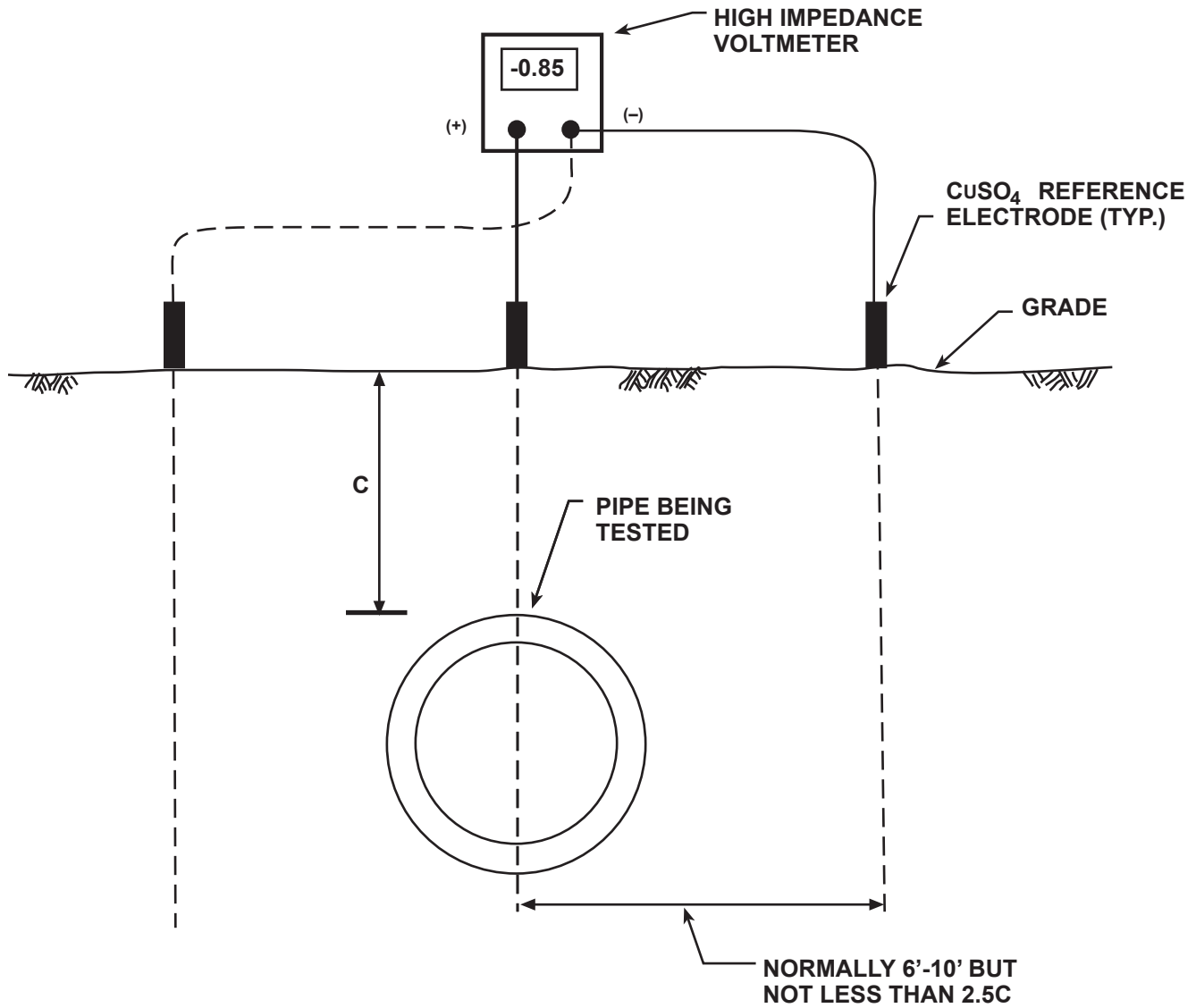

TYPICAL TEST SET UP FOR SIDE DRAIN MEASUREMENTS

FIGURE 1-5

Normally, after the survey data is plotted, the -850 mV value is red-lined on the plot. All areas below this line are considered to be inadequately protected and in need of remedial measures. Figure 1-6 shows a typical pipe-to-soil potential profile of a cathodically protected pipeline.

On pipelines which are not cathodically protected, the pipe-to-soil potential profile and surface potential surveys can be used to locate corroding areas or "hot spots" along the pipeline. Experience has shown that when a difference in pipe-to-soil potential values exist along a pipeline, corrosion occurs at, and for a given distance on either side of, the most negative or anodic points along the pipeline.

Figure 1-7 shows some typical potential and polarity changes which may be recorded at corroding or anodic areas on the pipe. The exact point of "current discharge" can be determined by resurveying the effected area and successively reducing the electrode spacing by one-half. When the exact point of maximum "current discharge" (most negative potential) has been determined, the point should be staked, and all pertinent data recorded.

Pipe-to-soil potential measurements taken over the line can be used to indicate whether or not a pipeline is being subjected to dynamic stray current corrosion. This is possible however, only if the potentials are fluctuating at the time of the survey. The two potential profile method is sometimes used to detect the effects of static stray currents on a section of pipe. The first profile is developed with the reference electrode placed directly above the pipe and the second by placing the electrode some distance laterally away from the pipe.

Dual potential profiles, over the pipe and laterally away from the pipe, are used to interpret various types of corrosion activity on unprotected pipes. It should be noted, however, that such profiles should be utilized to evaluate the effects of "long line" corrosion cells. Such profiles can sometimes overlook very small

localized corrosion cells where the anode and the cathode are located very close to each other.

PIPE-TO-SOIL POTENTIAL SURVEYS AND ANALYSIS

Figure 1-8 shows a typical potential profile on a pipe on which the corrosion activity is one of straight forward galvanic action and is not being influenced by interference currents or bimetallic corrosion. Figure 1-9 shows a typical potential profile on a pipe which is exposed to damage as a result of a rectifier unit on a crossing pipeline. In comparing these two potential profiles, it should be noted that irrespective of the condition which exists, anodic areas always exist at the locations where the "over the pipe" potentials are more negative than the "off the pipe" potentials. However, in a straightforward galvanic situation such as shown in Figure 1-8, the anodic areas occur at locations where the "over the pipe" potentials are of higher negative values than those measured in the cathodic areas. In an interference situation such as shown in Figure 1-9, the anodic areas are at those locations where the potentials (both "over" and "off" the pipe) are of lower negative values than those at the cathodic areas.

It should be noted that although a potential profile similar to that shown in Figure 1-8 almost always indicates a galvanic corrosion pattern and almost always rules out a stray current or interference situation, a profile similar to that shown in Figure 1-9 does not necessarily indicate a stray current situation. It is possible that a bimetallic corrosion condition will yield a potential profile similar to that which is encountered in an interference situation. Figure 1-10 shows a potential profile on a pipeline, a portion of which is influenced by a neighboring copper grounding system to which the pipe is connected. It can be seen that this potential profile is very similar to that shown in Figure 1-9 in that the anodic areas occur at locations of low negative potential. In some situations, it may be difficult to distinguish between an interference situation and a bimetallic one merely by analyzing the potential profiles. In

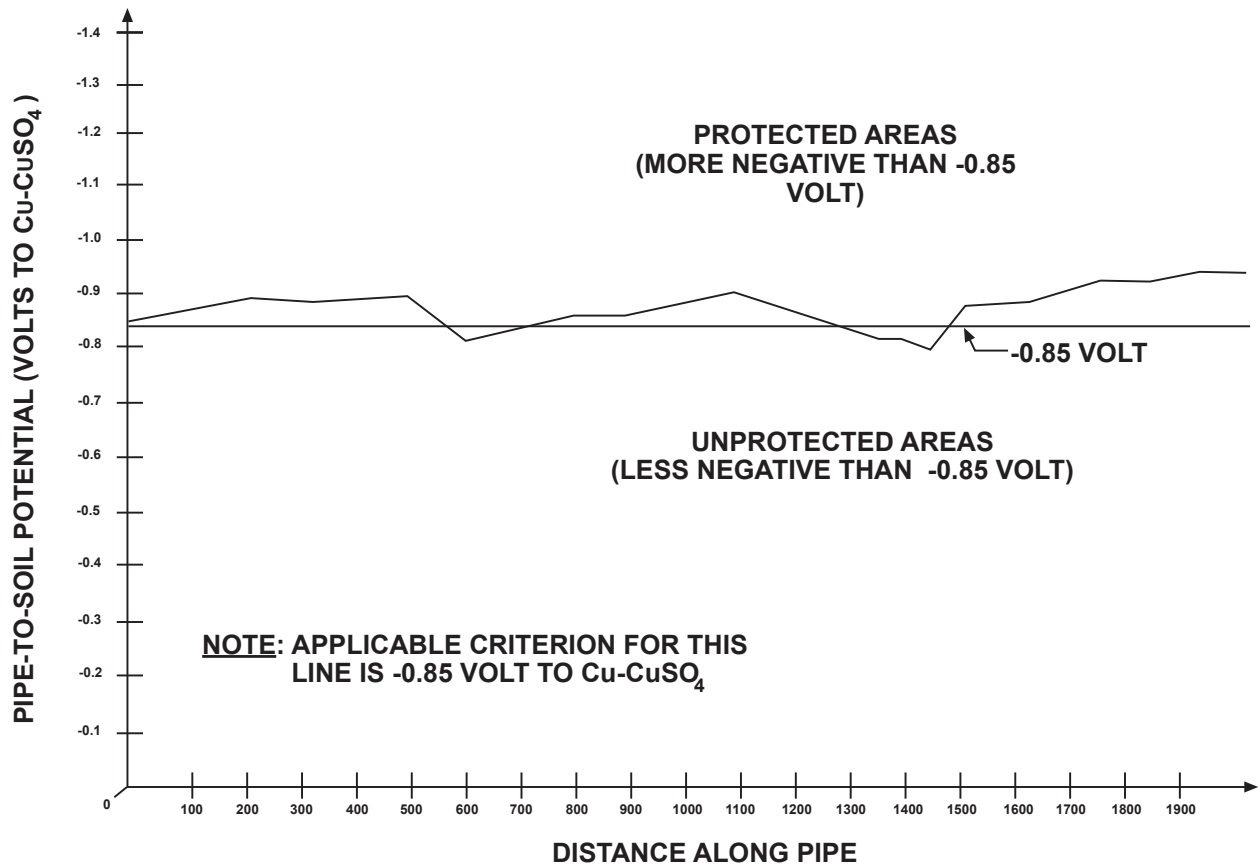

TYPICAL POTENTIAL PLOT OF A CATHODICALLY PROTECTED PIPELINE

FIGURE 1-6

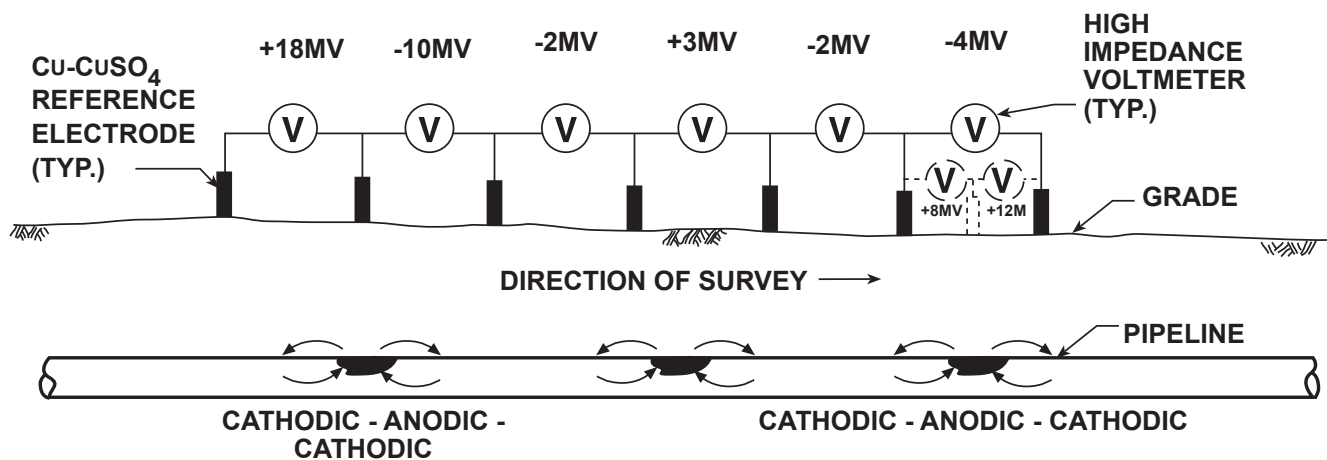

SCHEMATIC SURFACE POTENTIAL SURVEY

FIGURE 1-7

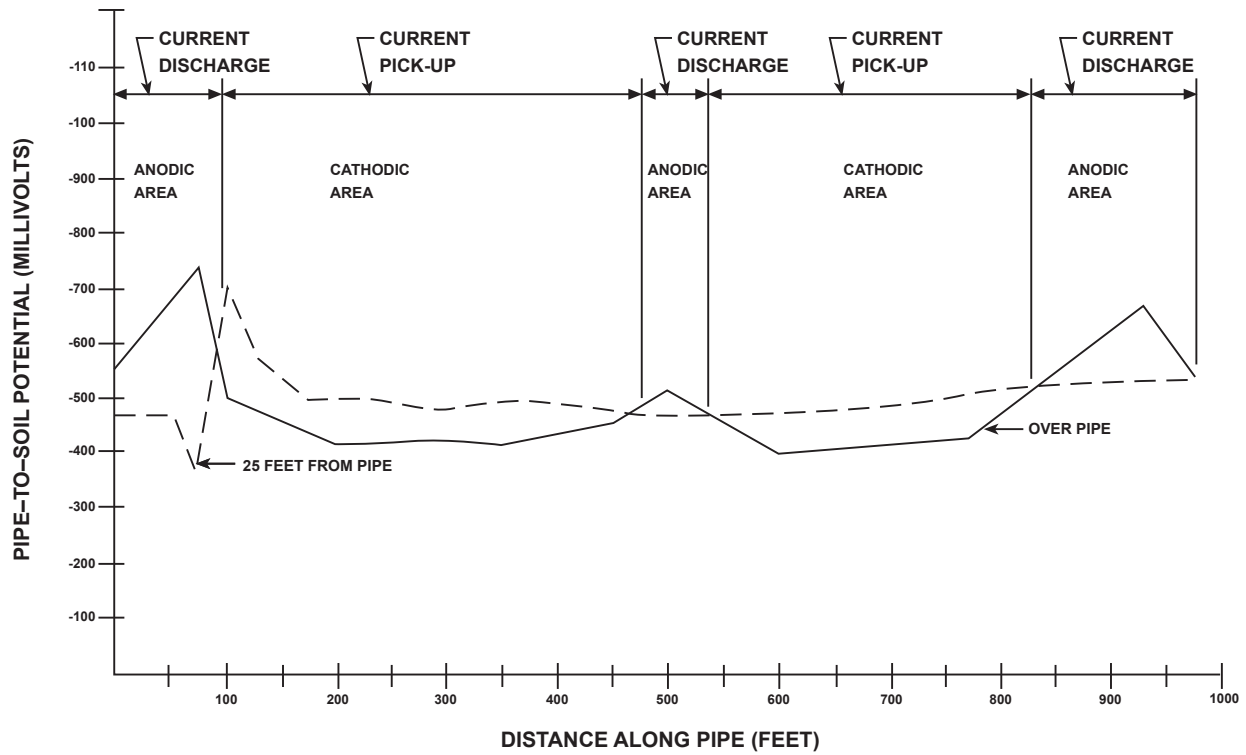

POTENTIAL PROFILE SHOWING GALVANIC CORROSION ACTIVITY

FIGURE 1-8

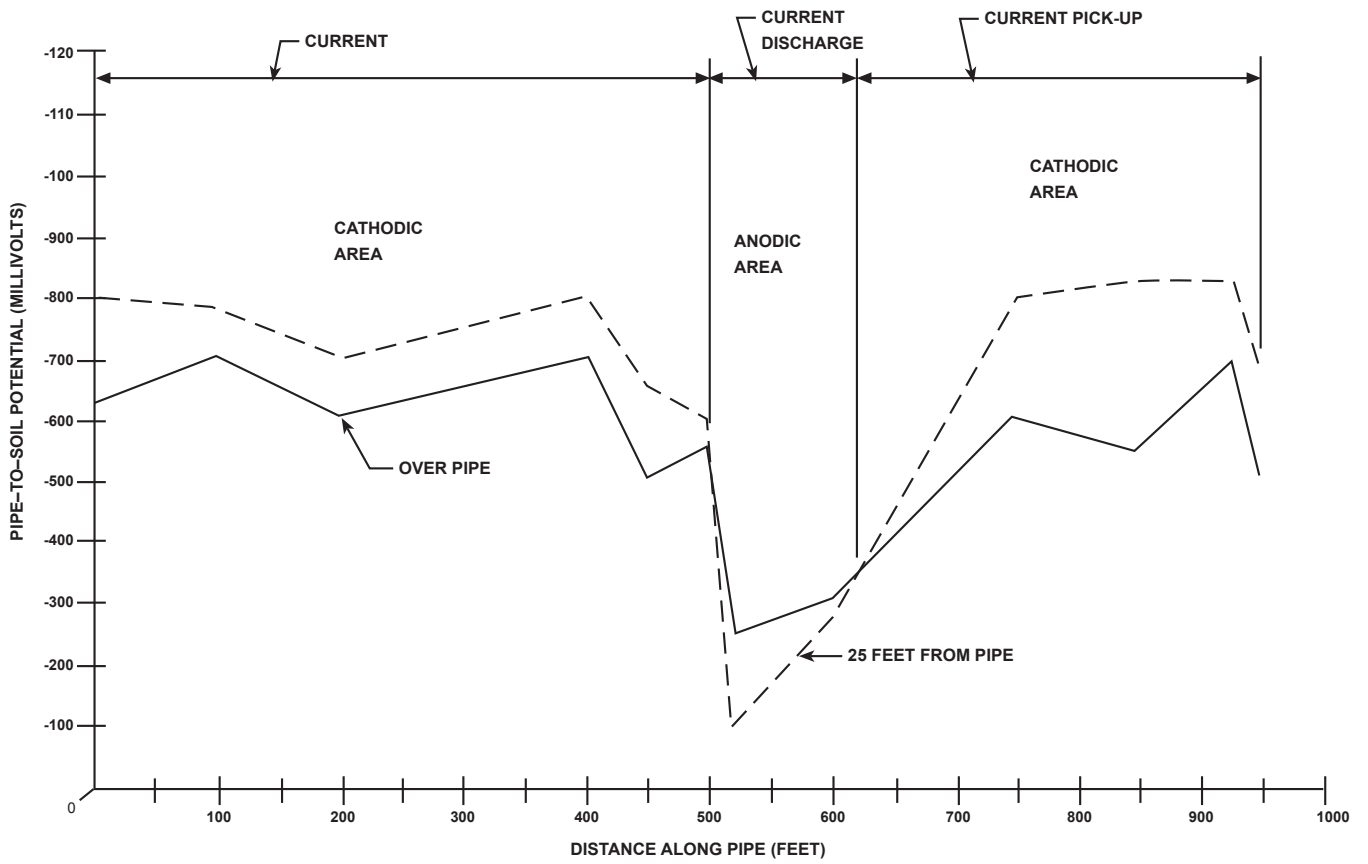

POTENTIAL PROFILE OF PIPE EFFECTED BY STRAY CURRENT INTERFERENCE

FIGURE 1-9

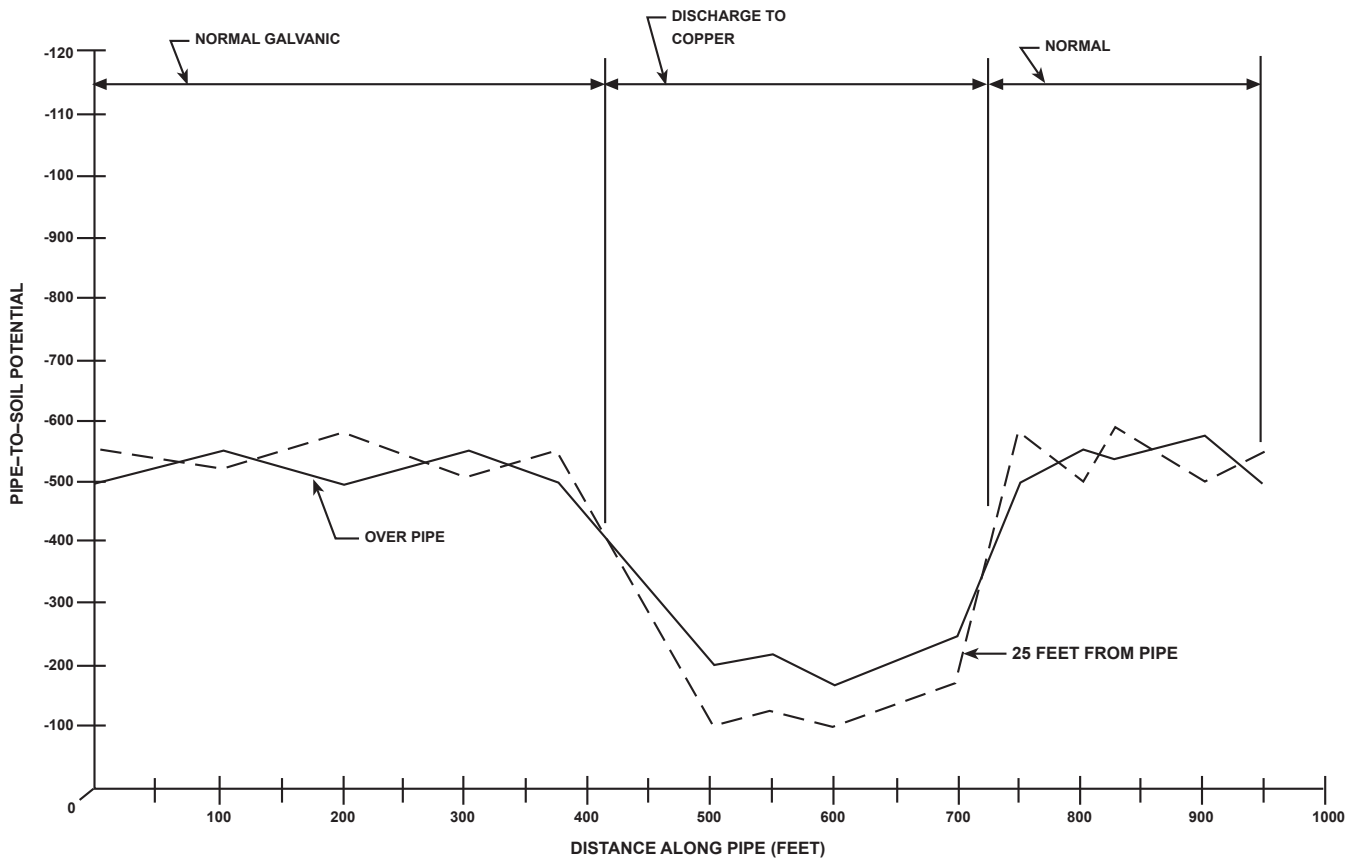

POTENTIAL PROFILE SHOWING BIMETALLIC EFFECT

FIGURE 1-10

that type of situation, a complete investigation of the conditions which exist in a given area will usually yield the information necessary to establish whether the potentials are attributable to interference or bimetallic activity.

Even without knowledge of the surrounding conditions, there are usually sufficient differences between two profiles to distinguish them. Thus, in an interference situation, the portions of the pipe immediately adjacent to the anodic area are almost always entirely cathodic. In a bimetallic situation, the profile of the pipe outside the area of bimetallic influence is one which is similar to the normal galvanic profile shown in Figure 1-8.

For the purpose of distinguishing the type of corrosion activity that is present, in the absence of a cathodic protection system, the following general rules can be given.

1. Anodic areas exist at locations where the lateral (off the pipe) measurements are less negative than the "over the pipe" measurements. Conversely, cathodic areas exist at locations where the lateral measurements are more negative than the "over the pipe" measurement. This condition always holds, irrespective of whether the corrosion activity is a result of an electrolytic or galvanic action.
2. When anodic areas coincide with areas of high negative potential, the corrosion activity is one of "straightforward" galvanic action (this does not include bimetallic activity). In a straightforward galvanic situation, the more negative the potential, the more anodic the condition will be.
3. When anodic areas coincide with areas of low negative potentials (or in severe cases, positive potentials), the corrosion activity is one of either electrolytic action or bimetallic coupling. In an electrolytic or bimetallic situation, the less negative (or more positive) the potential, the more anodic the area.

INTERPRETATION OF POTENTIALS UNDER NON-STRAY CURRENT CONDITIONS

After it has been determined that stray currents are not present, potential measurements can be used in analyzing the galvanic corrosion pattern which may exist. Surface condition of the pipe, chemical composition of the soil, and other local conditions can greatly influence static potentials along the length of a pipeline. Therefore, the more readings taken, the better the evaluation. A more comprehensive interpretation of potential measurements can be derived from the following statements.

1. The potentials of newer pipes are more negative than those of older pipes.
2. The potentials of coated pipes (organic coating such as coal tar, asphalt, plastic tape, etc.) are more negative than those of bare pipes.
3. The variation in potential with respect to distance is generally greater along a bare pipe than along a coated pipe.
4. The normal potentials taken along a bare pipe fall in the range of -500 to -600 mV. A newly installed bare pipe will have higher negative potentials, and very old bare pipe can have much lower negative potentials.
5. The normal potentials taken along a coated line fall in the range of -650 to -750 mV. A newly installed coated pipe can have higher negative potentials, and older pipe or poorly coated pipe will have less negative potentials.
6. In highly alkaline soils, the normal potentials will be less negative than those taken in neutral or acidic soils.
7. On bare pipe, there is usually a correlation between potential measurements and resistivity measurements, i.e., locations of higher resistivity soil correspond with locations of lower negative potentials.

It should be understood that all of the above statements apply primarily to steel pipelines that are in non-stray current areas and are not subject to bimetallic influences or cathodic protection. Also, where comparisons are made, such as between coated and bare pipe or between old and new pipe, it is assumed that other conditions are equal.

These statements are intended as a generalized guide for interpretation of potential measurements. They are not to be considered as scientific principles and they do not necessarily hold true under all circumstances. They are merely a summation of field experience. They are not derived from controlled experiments or rigid reasoning. Despite the apparently severe qualifications that have been applied to these statements, if they are used with care and with complete appreciation of the theory of galvanic corrosion, most corrosion problems can be evaluated successfully.

COATED CROSS-COUNTRY PIPELINE WITHOUT CATHODIC PROTECTION

The potential measurements shown in Table 1-2 were recorded during a pipe-to-soil potential survey along a portion of a well-coated, cross-country pipeline. Examining the data in the table we see that about one-half of the readings/locations fall in the range as indicated in statement 5, measurements at five of the metering and regulator stations were less negative than those given in statement 5. (The potential of -780 mV at location 31 is slightly more negative than the range given in statement 5, but as indicated in that statement, higher negative potentials are possible on newly installed, well-coated pipes.)

The low negative potentials at the metering and regulator stations prompted a more detailed investigation.

This investigation found that the isolators that had been installed at those stations were shorted, and as a result, the coated line was directly coupled to older uncoated distribution

pipings at those locations.

Statements 1 and 2 indicate that older, bare lines are of lower negative potentials than newer, coated lines. The coupling of the coated line to the bare line makes the potentials on the coated line less negative at the shorted meter and regulator stations than along the balance of the pipeline. This situation shows the importance of placing isolating flanges between new coated pipe and older bare pipe. This isolation is needed whether or not cathodic protection is provided for the coated line. If cathodic protection is not provided, the new coated pipe will be anodic with respect to the older, bare pipe. As a result, if there were no isolating flange installed between the two sections, or if the flange were shorted, the newer coated section of pipe would be subjected to accelerated galvanic corrosion attack. When using isolating flanges or devices, safety precautions must be followed to prevent a spark or arc across the isolator during a fault or power surge or static discharge. Devices exist that will maintain DC isolation while acting as a shunt under the above conditions.

GAS SERVICE LINE

The previous example shows the need for a thorough investigation of a situation where there is an apparent contradiction between the measurements taken and the statements listed. The next example illustrates this need in a slightly more complicated situation. In this example we have gas service lines in a housing development. The original service lines had been installed without coating, and failures began to appear after five years. The lines which failed were replaced with coated steel pipes, and some of the replacement pipe developed leaks within only two years of service. A potential survey conducted on the system found a range of potentials from -250 to -350 mV on the new coated replacement lines and potentials ranging from -500 to -600 mV on the older bare lines.

Examination of these data tends to indicate a contradiction to statements 1, 2, and 5. Upon

TABLE 1-2**Potential Measurements**

Test Station Location No.	Description of Location	Pipe-to-Soil Potential (millivolts)
21	Crestdale Regulator Station	-703
22	North side of Blue River on Rt. 95	-700
24	South side of Blue River	-735
26	Linden Metering Station	-542
26	Valve box approximately 7.8 miles South of Blue River	-730
28	Creek, 10.2 miles south of Blue River	-674
30	Atlantic Regulator Station	-563
31	Glendale Metering Station	-780
32	Crossing of railroad near Glendale	-506
33	Forest Park Regulator No. 1	-480
35	Forest Park Regulator No. 2	-537

closer inspection however, it was discovered that the water service lines in the development were electrically continuous with the gas service lines. Copper, being cathodic with respect to steel, will when connected to a steel pipe, cause the potential of the steel pipe to become less negative than its natural potential. As a result of area relationships (the ratio of areas of copper to steel is greater when the steel is coated than when it is bare), the effect of copper on the potential of coated steel pipe will be far greater than that on the potential of bare pipes.

GROUNDING SYSTEM

The next example involves a somewhat similar situation as the previous example, but an extensive copper electrical grounding system is involved rather than copper pipes.

A potential profile was conducted on a newly installed, underground, coated steel pipe. The over-the-line potentials were in the range of -600 to -700 mV, which seems to be in accordance with the previous statements. An off-the-line potential profile was also conducted on the line. Interestingly, the two profiles were nearly identical.

Potential profiles were also conducted along another newly installed, well coated pipeline in a similar environment. In this case, however, there was an extensive grounding system installed along the pipeline and electrically connected to it. The grounding system consisted of copper mats installed at 50 foot intervals. The potentials measured along the pipeline were considerably less negative than expected along a coated pipe; all of the potentials were less negative than -500 mV, and at some locations the potentials were less negative than -300 mV. In addition, the off-the-line potentials were considerably less negative than the over-the-pipe potentials.

These low negative potential levels and the lateral potential gradients are directly attributable to the copper grounding system and indicate that severe bimetallic (galvanic)

corrosion activity exists. In fact, the condition at this plant was so severe that leaks developed within the first year of operation despite the fact that the pipeline was extremely well-coated and had been backfilled with sand. The very good coating no doubt contributed to the rapid development of leaks on the pipeline due to the concentration of current discharge at holidays in the coating. The corrosion current was generated by the bimetallic coupling.

STEEL GAS AND WATER LINES

In the examples given thus far, it is possible that the bimetallic effect of copper could have been anticipated without having a complete knowledge of the potential pattern. The next example, however, describes a situation which is similar to a bimetallic corrosion pattern but where there is no copper present. This example involves a group of school buildings. Leaks occurred on these pipes within the first year, and these leaks were attributed to the very corrosive soil in which resistivity was less than 100 ohm-centimeters. However, potential measurements taken on the gas and water lines were all in the range of -350 to -450 mV. If the corrosion activity was one of straightforward galvanic action resulting from the corrosiveness of the soil, these potentials would be considered as very cathodic and, therefore, not indicative of a very corrosive condition. Therefore, it was difficult to reconcile the very severe corrosion history with the apparent cathodic potentials.

Because the soil at this location was very alkaline, somewhat lower potentials than normal would be expected. However, the very low negative potentials at this site could not be entirely attributed to the alkaline soil. More detailed investigation found that the low potentials on the gas and water lines were caused by the radiant heat piping under each of the buildings. Although the radiant heat lines were also steel, they were installed in concrete, and the normal potential of steel in concrete is approximately -200 mV, versus the normal -500 to -600 mV potential of steel in earth. The electrical coupling of the gas and water lines in

the soil to the radiant heat lines in the concrete (there were common structural connections in the boiler room) made the potential on the gas and water lines less negative than normal. These gas and water lines thus behaved as the anode in a mechanism which is similar to a bimetallic couple. The conditions which made this couple particularly severe were the low resistivity soil, the proximity of the gas and water lines to the radiant heat lines, and the fact that the area of the gas and water lines was small compared to the area of the radiant heat lines. This area relationship was made still worse by the fact that the gas and water lines were coated.

The examples given show the manner in which pipe-to-soil potential measurement can be used in analyzing a corrosion problem. These examples further show the need for learning as much about the structure under investigation as possible and about any other structures in the area. The remaining part of this chapter deals with the current NACE criteria for cathodic protection of steel and cast iron structures and some of their applications.

CRITERIA FOR CATHODIC PROTECTION

Cathodic protection criteria are listed in NACE Standard Practice SP0169-2007 "Control of External Corrosion on Underground or Submerged Metallic Piping Systems".

Paragraph 6.1.1 of SP0169-2007 states "This section lists criteria and other considerations for CP that indicate, when used either separately or in combination, whether adequate CP of a metallic piping system has been achieved."

SP0169-2007 lists three (3) main criteria for the cathodic protection of steel and cast iron structures. These criteria are as follows:

1. A negative (cathodic) potential of at least 850 mV with the CP applied. This potential is measured with respect to a saturated copper/copper sulfate reference electrode contacting the electrolyte. Voltage drops other than those across the structure-

to-electrolyte boundary must be considered for valid interpretation of this voltage measurement.

2. A negative polarized potential of at least 850 mV relative to a saturated copper/copper sulfate reference electrode.
3. A minimum of 100 mV of cathodic polarization between the structure surface and a stable reference electrode contacting the electrolyte. The formation or decay of polarization can be measured to satisfy this criterion.

SP0169-2007 also states "It is not intended that persons responsible for external corrosion control be limited to the criteria listed below. Criteria that have been successfully applied on existing piping systems can continue to be used on those piping systems. Any other criteria used must achieve corrosion control comparable to that attained with the criteria herein."

Some examples of other criteria that have been used in the past are:

- Net Current Flow
- E-log I Curve
- 300 mV Shift

The criteria listed for steel and cast iron, as well as the criteria given for other metals, require pipe-to-soil potential measurements. When these criteria are to be applied in a particular situation and potential measurements are taken, a number of questions that are not always precisely answerable arise:

1. Which criterion or criteria are applicable to the particular corrosion mechanism?
2. Where should the reference electrode be placed to obtain valid readings?
3. How many readings are required to obtain an accurate representation of the entire pipeline or piping network?

WHICH CRITERION?

The selection of the criterion to use should be governed not merely by what is most convenient for the user. It should be recognized as a function of the particular corrosion mechanism being considered.

POTENTIAL MEASUREMENT OF -850 mV TO A Cu/CuSO₄ REFERENCE ELECTRODE WITH CATHODIC PROTECTION APPLIED

Of the three criteria listed above, the -850 mV criterion with cathodic protection applied has historically been the one most widely used for determining if an acceptable degree of cathodic protection has been achieved on a buried or submerged metallic structure. In the case of a steel structure, an acceptable degree of protection is said to have been achieved when at least a -850 mV potential difference exists between the structure and a CSE contacting the soil directly above and as close to the pipe as possible.

Some sources indicate that this criterion was developed from the fact that the most negative native potential found for coated steel was -800 mV. Therefore, the assumption was made that if sufficient current is applied to raise the potential of the entire structure to a value more negative than the open circuit potential, then the effects of corrosion will be mitigated. A potential of -850 mV with respect to a saturated copper/copper sulfate reference electrode was therefore adopted.

A potential of -850 mV or more negative, with the protective applied, to a CSE placed in contact with the soil directly over or adjacent to the steel structure would be an indication that adequate protection is being achieved at that point on the structure as long as any voltage drops (IR drops) across the electrolyte or through the metallic return path are taken into account. The wording for this particular criteria does state that voltage drops other than those across the structure-to-electrolyte boundary must be considered. Consideration is then defined as:

- “Measuring or calculating the voltage drop(s)”
- “Reviewing the historical performance of the cathodic protection system”
- “Evaluating the physical and electrical characteristics of the pipe and its environment”
- “Determining whether or not there is physical evidence of corrosion”

Voltage drops can be reduced by placing the reference electrode as close to the pipe surface as possible. It should be noted that this means “electrically” close, not just “physically” close. A reference electrode placed physically close to a well coated pipe is not electrically close to it and voltage drops are not reduced.

The voltage drop can also be eliminated by interrupting all sources of cathodic protection current and measuring the “off” potential. The instantaneous “off” potential should be free of voltage drop error. Comparison of the “on” and “off” potentials and noting the difference between them will indicate the approximate voltage drop included in the potential measurement when the measurement is made with protective current applied. This “instant off” or polarized potential will be discussed in more detail when the second listed criterion is analyzed.

Voltage drops are more prevalent in the vicinity of an anode bed or in areas where dynamic stray currents are present. Unusually high resistivity soil will also cause high voltage drops. In areas where dynamic stray currents are present, an instantaneous reading may be impossible to accurately record and therefore meaningless. The use of voltage recording instruments is recommended so as to obtain potential values over a 24-hour period, or at least during the known period of highest stray current activity. Often times it is possible to obtain fairly stable potentials of the piping system once the DC transit system stops operating in the early morning hours if recording

instruments are left in place overnight. These potentials can provide a base-line from which to evaluate other measurements.

The -850 mV criterion with cathodic protection applied is the one which is almost always used in areas with significant dynamic stray current activity. It is generally accepted that if the potential of the structure to a CSE remains more negative than -850 mV at all times, even if there are substantial fluctuations in potential with time, then the pipe can be considered protected at that particular test point. It is possible that the amount of test points surveyed and the frequency at which those surveys are performed may have to increase in heavy stray current areas due to ever-changing conditions.

Limitations of the -850 mV Potential to a Cu/CuSO₄ Reference Electrode With Cathodic Protection Applied Criterion

A limitation of this criterion for insuring total protection is that potentials can vary widely from one area of the underground structure to another as a result of coating damage, interference effects, etc. This suggests the possibility of potentials being less negative than -850 mV in sections of the pipe between two consecutive test locations. Also, the voltage drop component in the potential measurement has to be considered unless the “instant off” or polarized potential of -850 mV is used. In many cases, removal of the voltage drop component or testing for polarized potentials may be difficult, particularly when it is not possible to remove and/or interrupt all sources of cathodic protection current. Piping systems protected by multiple galvanic anode installations is an example of a situation in which interrupting all sources of cathodic protection current may be impractical.

More negative potentials than -850 mV can of course be maintained at all test points, which could insure a greater degree of protection between test points. However, economics is a factor to consider; higher potentials may result in a higher power consumption. Additionally, in this situation, care has to be exercised to insure

that the polarized potential of the pipeline does not reach values at which coating damage could occur due to hydrogen evolution at the surface of the pipeline.

Although this accepted criterion can be, and is, widely used for all types of structures because of its straightforward approach and simplicity, its most economical use is in the case of coated structures. Use of this criterion to protect an old bare structure could require substantially higher protective current than if one of the other criterion were used.

Another limitation of this criterion is due to the requirement that potential readings be taken with the reference electrode contacting the electrolyte directly over or adjacent to the pipeline to minimize voltage drop. In cases of river crossings, road crossings, etc., where the electrode cannot be properly placed, an alternative criterion may have to be used.

POLARIZED POTENTIAL OF -850 mV MEASURED TO A Cu/CuSO₄ REFERENCE ELECTRODE

As discussed in the previous criteria section, one method of considering the voltage (IR) drop across the electrolyte is to measure the structure potential with all current sources “off”. The potential that is then measured would be the polarized potential of the structure at that particular test location. A polarized potential is defined in Section 2 of SP0169-2007 as, “The potential across the structure/electrolyte interface that is the sum of the corrosion potential and the cathodic polarization”. The difference in potential between the static or native potential and this polarized (instant off) potential would be the amount of polarization that has occurred due to the operation of the cathodic protection system. In the same section of SP0169-2007 polarization is defined as, “The change from the open-circuit potential as a result of current across the electrode/electrolyte interface.”

Limitations of the Polarized Potential of -850 mV Measured to a Cu/CuSO₄ Reference Electrode Criterion

Polarized potentials well in excess of -850 mV should be avoided for coated structures in order to minimize the possibility of cathodic disbondment of the coating. SP0169-2007 also points out that, "Polarized potentials that result in excessive generation of hydrogen should be avoided on all metals, particularly higher strength steel, certain grades of stainless steel, titanium, aluminum alloys, and prestressed concrete pipe."

100 mV POLARIZATION CRITERION

The 100 mV polarization criterion, like the -850 mV polarized potential, is based on the development of polarization. This causes the structure to exhibit a more negative potential than in its native state.

Measurement of the polarization shift can be determined by either measuring its formation or decay. Determination of the amount of polarization is normally made during the polarization decay (positive shift) period subsequent to de-energizing the cathodic system, or in the case of galvanic anodes, when they are disconnected. When cathodic protection system is de-energized, there is an immediate rapid drop of potential. The polarization decay does not include this drop. The potential of the structure after this initial rapid drop is recorded and used as a basis for determining the polarization shift. To obtain the total polarization shift, the final potential after polarization decay has taken place is measured and subtracted from the potential read immediately after the cathodic system has been turned off or disconnected. If this total shift is 100 mV or more, the structure is considered to be cathodically protected.

One drawback of this method is that the time required for full depolarization could take from hours to days for a coated structure to several weeks for a bare structure. This could make this method very time consuming and also might

leave the structure unprotected for an extended period of time. Normally however, the bulk of the depolarization will take place in the initial phase of the polarization decay; therefore it may not be necessary to wait the full decay period except in those cases in which the total actual polarization shift of the structure is relatively close to 100 mV. If, during the early phase of polarization decay measurement, the potential drops 100 mV or more, there is no real need (unless the actual value is desired) to wait for further de-polarization. If, on the other hand, the potential drop in the initial phase of the decay period is only on the order of 50 to 60 mV, it may be doubtful that the 100 mV shift will occur. In this case, a determination should be made as to whether a longer wait for total de-polarization is required and justifiable.

In order to determine the formation of polarization on a pipeline/structure, it is first necessary to obtain static or native potentials (before the application of cathodic protection current) on the structure at a sufficient number of test locations. Once the protection system is energized and the structure has had time to polarize, these potential measurements are repeated with the current source interrupted. The amount of polarization formation can then be determined by comparing the static potentials with the "instant off" potentials.

Applications of the 100 mV Polarization Criterion

In many cases, the cost of the power required to achieve the 100 mV polarization decay criterion may be less than that required to meet either the -850 mV potential with cathodic protection applied criterion or the -850 mV polarized potential criterion. Further, the polarized potential corresponding to 100 mV of polarization may be less negative than -850 mV. This criterion takes into account only the polarization film on the pipe surface and is independent of any voltage (IR) drops in the soil or at the structure electrolyte interface. This criterion should not be used in areas subject to stray currents because any outside interference would tend to break down the polarization at the

point of discharge. The results obtained under these conditions could be misleading. Corrosion personnel must determine the effectiveness of this criterion in areas of stray current activity.

The 100 mV polarization criterion is mostly used on poorly coated or bare structures and in some instances could be useful in large pipe networks as in compressor and regulating stations where the cost of a cathodic protection system to achieve either a -850 mV “on” potential or a -850 mV polarized potential may be prohibitive. However, in an economic analysis, the additional cost of conducting future periodic surveys has to be taken into account; as the use of the 100 mV criterion is somewhat more complicated and costly than the use of the -850 mV criteria with the cathodic protection applied.

This criterion can be used on metals other than steel where there could be some question as to what specific potential to use as an indication of protection. This criterion is often used for those installations where it is impractical to meet either of the -850 mV criterion.

In piping networks, where new pipe is coupled to old pipe, it may be good practice to use the -850 mV polarized potential criterion for the new pipes and the 100 mV polarization criterion for the older pipes.

Limitations of the 100 mV Polarization Criterion

The limitations for the 100 mV polarization criterion are as follows:

- Interrupting all DC current sources is not always possible.
- Stray current potential variations can make this criterion difficult to measure.
- If dissimilar metals are coupled in the system, protection may not be complete on the anodic metal.

- The only additional limitation is related to the time required for the pipe to depolarize. In some cases, adequate time may not be available to monitor the polarization decay of the pipe to the point where the criterion could have been met.

CRITERIA FOR SPECIAL CONDITIONS - NET PROTECTIVE CURRENT CRITERION

This criterion is listed in Section 6 of SP0169-2007 under a special conditions section to cover those situations for bare or ineffectively coated pipelines where it appears that long line corrosion activity is the primary concern.

This protection criterion is based on the premise that if the net current at any point in a structure is flowing from the electrolyte to the structure, there cannot be any corrosion current discharging from the structure to the electrolyte at that point. The principle is based on first locating points of active corrosion and then measuring current flow to or from the structure.

Some pipeline companies use the side drain method for application of this criterion on the basis that if the polarity of the voltage readings on each side of the structure indicates current flow towards the structure, then the structure is receiving protective current. If the electrode located over the pipe is positive with respect to the other two electrodes, then current is discharging from the pipe to the electrolyte and corrosion is taking place.

The above statement is considered correct as long as there are no outside sources of influence such as other pipelines or other gradient sources such as stray currents. In cases where other gradient sources exist, the results could be misleading. The results might also be questionable in areas with high resistivity surface soil, for deeply buried pipelines, or where local corrosion cell exists.

Applications of the Net Protective Current Criterion

This criterion is normally used on uncoated

structures. The “side drain’ surface method is normally used in cases of single isolated pipelines to obtain an indication of whether the pipeline was receiving cathodic protection. If the electrodes that are placed perpendicular to the pipeline (remote) are positive in relation to the electrode over the pipeline, it was assumed that current is flowing toward the pipe.

In cases where there are sources of outside gradients, it may be difficult to evaluate the results of these tests properly.

Limitations of the Net Protective Current Criterion

The use of this criterion is to be avoided in areas of stray current activity because potential variations could interfere with its use. Also, extreme care must be taken in common pipeline corridors because other gradient sources may exist that could result in erroneous or misleading measurements.

Even though the results indicate a net current flow towards the pipe/structure, that net current flow is indicative only of what is happening at the specific point of test and does not represent what may be happening at other points on the pipeline/structure. Pipeline companies that use the side drain method for application of this criterion, normally require that tests be conducted at close intervals (2 to 20 feet along the pipeline).

OTHER CRITERIA

The two criteria listed below have been used in the past and are presented for information.

E-LOG I CURVE CRITERION

The E-Log I technique in itself is not so much a criterion of protection as it is a means of determining the correct amount of cathodic protection current required for a structure. Being complicated in application, the E-log I criterion is limited to specialized applications where other methods may be inadequate.

Applications of the E-Log I Curve Criterion

The E-Log I Curve criterion is not generally used by itself to evaluate existing cathodic protection systems. Its primary use is to determine the potential value, measured with respect to a reference electrode, which will give a specific minimum current value required for protection. This potential value is to be at least as negative (cathodic) as that originally measured at the beginning of the Tafel segment of the E-log I curve.

Once the current value and the potential to a remote electrode have been established, future surveys consist of checking the current output of the cathodic protection system and the potential of the structure to a remote electrode. It is important that the reference electrode be located in the same place where it was located during the E-Log I tests. Because the test method involved is rather elaborate, the use of this method is generally limited to structures where conventional means of determining current requirements would be difficult. Examples of such structures are pipeline river crossings, well casings, piping networks in a concentrated area, and in industrial parks.

Limitations of the E-Log I Curve Criterion

The main limitation of this technique is that testing is elaborate, thus making it relatively slow in comparison to that required for other criteria. Future tests are relatively simple, however. The remote reference electrode has to be located exactly at the same locations where it was placed during the E-Log I tests. Because the E-Log I curve is time dependent, there is no guarantee that a repeat E-Log I curve will yield the same minimum potential or current for protection as an earlier curve.

Using this criterion in areas where stray currents are present could result in erroneous results as the stray currents may affect the readings and make obtaining a good polarization curve impossible due to the fluctuations in the structure potential.

300 mV POTENTIAL SHIFT CRITERION

As opposed to working toward a certain minimum potential value to a reference electrode as discussed in some of the previous sections, the 300 mV potential shift criterion is based on changing the potential of the structure in the negative direction by a specified minimum amount. The minimum potential shift for steel, as used in the past is 300 mV. Any stable reference electrode may be used with this criterion because the method consists of measuring a potential shift and is independent of the actual potential of the electrode. Determination of the voltage shift is made with the protective current applied.

The development of this criterion appears to have been largely empirical or experimental in nature. Although 300 mV is the Figure commonly used at this time, other values such as 200 or 250 mV have also been used in the past. There were, however, two considerations that supported this criterion, recognizing that corrosion prevention still may not be 100% complete.

The first consideration was that 300 mV may be greater than the driving potential of most of the galvanic cells on a structure to be protected. By shifting the structure in the negative direction by 300 mV, the majority of the cells should be overcome.

The second consideration was based on tests conducted by Marcel Pourbaix. His work showed that if a protective potential applied to a structure is made more negative by equal increments starting from the natural or static potential, the first increment would yield the greatest reduction in corrosion rate and subsequent increments would result in progressively smaller reductions in the corrosion rate per increment. Experience indicated that the 300 mV shift encompassed sufficient reduction in the rate of corrosion to make it a somewhat effective criterion for practical applications.

Later evaluation of this criterion by a NACE

committee concluded that the actual measurements or shift was not representative of what was occurring on the surface of the structure. This is due to the fact that when a cathodic protection system is energized, an immediate shift of potential, due to a voltage (IR) drop, will be seen. In this particular application this voltage drop value is included in the measured shift.

Applications of the 300 mV Potential Shift Criterion

This criterion has been used for entire structures and also for hot-spot protection. It is mainly used for bare steel structures which have undergone a slow uniform corrosion rate due to their age. These structures/pipes normally have a natural potential range from about -200 mV to -500 mV as a result of oxidation products developing on the external surfaces. This criterion has also been used on some coated pipelines where soil conditions alter the natural or static potential of the steel to -500 mV or lower. In this case, the 300 mV shift may also be easier to attain than achieving a potential reading of -850 mV, and could be expected to stop the majority of corrosion.

The 300 mV potential shift criterion is almost always more applicable to impressed current systems than galvanic anode systems. The reason is that the native state potential may be such that a limited number of galvanic anodes will not produce the required change of potential on the structure to be protected.

Limitations of the 300 mV Potential Shift Criterion

The 300 mV potential shift in some instances is impractical to use and in other cases, may not correctly indicate the level of cathodic protection achieved. Some galvanic cells may still be active even after the 300 mV shift is obtained and there could be areas between adjacent structure to electrolyte readings where the 300 mV shift is not being attained. Furthermore, a pipeline subject to stray currents could have positive potentials with respect to a

CSE even after the pipe potential is shifted in the negative direction by 300 mV. If the potential of the structure is fluctuating more than the shift required, this criterion cannot be valid.

If the steel structure is coupled to a more noble metal, a 300 mV shift might indicate that much of the adverse effect produced by the dissimilar metal union has been overcome, but it would not necessarily indicate that complete cathodic protection is being provided to the steel structure/pipeline itself.

USE OF CRITERIA

It must be noted that there will be situations or conditions where a single criterion cannot be used to evaluate the effectiveness of a cathodic protection system and it is necessary to employ a combination of criteria.

There will also be situations when the application of the criteria listed may be insufficient to achieve protection. Some examples pointed out in the SP0169-2007 are situations where the presence of sulfides, bacteria, elevated temperatures, acid environments, and/or dissimilar metals increase the amount of current required for protection. At other times values less negative than those listed may be sufficient. SP0169-2007 lists examples such as a pipeline encased in concrete or dry or aerated high resistivity soil.

REFERENCES

1. NACE Standard Practice SP0169-2007 "Control of External Corrosion on Underground or Submerged Metallic Piping Systems", NACE International, Houston, Texas

CHAPTER 2

EVALUATION OF UNDERGROUND COATINGS USING ABOVEGROUND TECHNIQUES

INTRODUCTION

This chapter describes the indirect inspection methods intended for use as part of the External Corrosion Direct Assessment (ECDA) process for detecting coating flaws and determining cathodic protection levels on buried pipelines. These methods are often more laborious than surveys completed as part of normal daily operating practices as a result of the requirement for precise data set alignment. Standard pipeline surveys generally investigate data trends over time or pipeline distance, while ECDA surveys look for small data variations over short distances.

This chapter describes the methods of conducting the following surveys for above grade indirect inspections. Other inspection methods can and should be used as required by the unique situations along a pipeline. The techniques described herein are not intended to illustrate the only methods by which these tools can be applied.

- *Pipeline Locating* is used to establish the location and centerline of the pipeline.
- *Direct Current Voltage Gradient (DCVG) Surveys* are used to locate and size coating holidays.
- *Alternating Current Voltage Gradient (ACVG) Surveys* are used to locate and size coating holidays.
- *Close-Interval Surveys (CIS)* are used to determine cathodic protection (CP) levels, electrical shorts to other structures, static

stray current conditions, and large coating holidays.

- *Alternating Current (AC) Attenuation Surveys* are used to assess coating quality and to detect and compare coating anomalies.

SURVEY SEQUENCE

The sequence in which the surveys are conducted is crucial to optimizing the survey techniques and data analysis. Coating holiday surveys (DCVG and ACFG) and AC attenuation surveys should be completed prior to a CIS survey. With surveys completed in this manner, pipe to electrolyte potentials can be measured directly above the coating holiday indications found using the DCVG or ACFG method.

Some ECDA surveys require existing CP systems to be turned off, the rectifier outputs increased, or systems disconnected. Structure potentials should be measured and recorded at sufficient locations to demonstrate that the pipeline has returned to the original level of polarization prior to completion of additional surveys that may be influenced by these actions. The structure potentials should be measured before and after these activities have taken place.

REFERENCED PROCEDURES

Additional information regarding the techniques cited in this chapter can be found in the latest revisions of the following documents:

- NACE/CEA 54277, Specialized Surveys for Buried Pipelines 1988
- NACE Standard TM0497, Measurement Techniques Related to Criteria for Cathodic Protection on Underground or Submerged Metallic Piping Systems
- NACE Standard SP0169, Control of External Corrosion on Underground or Submerged Metallic Piping Systems
- NACE Standard SP0177, Mitigation of Alternating Current and Lightning Effects on Metallic Structures and Corrosion Control Systems

DEFINITIONS

- a) Anomaly: Any deviation from nominal conditions in the external wall of a pipe, its coating, or the electromagnetic condition around the pipe.
- b) Cathodic Protection (CP): A technique to reduce the corrosion of a metal surface by making the surface the cathode of an electrochemical cell.
- c) Close-Interval Survey (CIS): A method of measuring the potential between the pipe and earth at regular intervals along the pipeline.
- d) Corrosion: The deterioration of a material, usually a metal that results from a reaction with its environment.
- e) Disbonded Coating: Any loss of adhesion between the protective coating and a pipe surface as a result of adhesive failure, chemical attack, mechanical damage, hydrogen concentrations, surface preparation and application problems, etc. Disbonded coating may or may not be associated with a coating holiday.
- f) ECDA Region: A section or sections of pipeline that have similar physical characteristics and operating history and in which the same indirect inspection tools are used.
- g) Electrolyte: A chemical substance containing ions that migrate in an electric field. For the purposes of this chapter, electrolyte refers to the soil or liquid adjacent to and in contact with a buried or submerged metallic piping system, including the moisture and other chemicals contained therein.
- h) Electromagnetic Inspection Technique: An aboveground survey technique used to locate coating defects on buried pipelines by measuring changes in the magnetic field that are caused by the defects.
- i) External Corrosion Direct Assessment (ECDA): A four-step process that combines pre-assessment, indirect inspections, direct examinations, and post assessment to evaluate the impact of external corrosion on the integrity of a pipeline.
- j) Fault: Any anomaly in the coating, including disbonded areas and holidays.
- k) Holiday: A discontinuity (hole) in a protective coating that exposes the structure surface to the environment.
- l) Indication: Any deviation from the norm as measured by an indirect inspection tool.
- m) Indirect Inspection: Equipment and practices used to take measurements at ground surface above or near a pipeline to locate or characterize corrosion activity, coating holidays, or other anomalies.
- n) IR Drop: The voltage difference between the On and Off pipe to soil potential.
- o) Microbiologically Influenced Corrosion (MIC): Localized corrosion resulting from the presence and activities of microorganisms, including bacteria and fungi.

- p) Pipe-to-Electrolyte Potential: See Structure-to-Electrolyte Potential.
- q) Pipe-to-Soil Potential: See Structure-to-Electrolyte Potential.
- r) Region: See ECDA Region.
- s) Structure-to-Electrolyte Potential: The potential difference between the surface of a buried or submerged metallic structure and the electrolyte that is measured with reference to an electrode in contact with the electrolyte.

area. Remote lightning strikes can create hazardous voltage surges that travel along the pipeline.

- Use caution when stringing test leads across streets, roads, and other locations subject to vehicular and pedestrian traffic. When conditions warrant, use appropriate barricades, flagging, and/or flag persons.
- Observe appropriate Company safety procedures, electrical codes, and applicable safety regulations.

SAFETY CONSIDERATIONS

Appropriate safety precautions, including the following, should be observed when making electrical measurements.

- Be knowledgeable and qualified in electrical safety precautions before installing, adjusting, repairing, removing, or testing impressed current cathodic protection equipment.
- Use properly insulated test lead clips and terminals to avoid contact with an unanticipated high voltage (HV). Attach test clips one at a time using the single-hand technique for each connection.
- Use caution when long test leads are extended near overhead high-voltage alternating current (HVAC) power lines, which can induce hazardous voltages onto the test leads. Refer to NACE Standard SP0177 for additional information about electrical safety.
- Use caution when performing tests at electrical isolation devices. Before proceeding with further tests, use appropriate voltage-detection instruments or voltmeters with insulated test leads to determine whether hazardous voltages, both AC and DC, may exist.
- Avoid testing when thunderstorms are in the

PIPELINE LOCATING

The pipeline must be located and marked to ensure that subsequent measurements are made directly above the pipeline. An inductive or conductive pipe locating device can be used. The pipe should be located within six (6) inches perpendicular of the pipe centerline and survey flags or paint marks placed directly above the pipeline every 100 feet using a slack chain distance technique or a measuring wheel. Slack chain stationing error shall be no more than 2% +/-.

The locating flags/paint marks can be numbered using a permanent marker by writing the flag number directly on the flag or painting the flag number on the ground. Numbering of the 100 foot stations will ensure that the different indirect survey techniques will be perfectly aligned by using the flag locations as the point of alignment.

The pipeline should be stationed beginning with 0+00 at the initial ECDA region and should progress in increasing station numbers in the direction of gas/product flow. The pipeline stationing should be reset to 0+00 at each following ECDA region start. As an alternative, actual pipeline as-built stationing can be used. With this method, the actual pipeline stationing is used for the initial start of the ECDA region and stationing continued until the end of the ECDA region.



**PIPELINE LOCATING CREW CLEARING PATH AND MARKING
PIPELINE CENTERLINE**

FIGURE 2-1



**PIPELINE LOCATION STATIONING FLAGS NUMBERED FOR PRECISE
DATA ALIGNMENT**

FIGURE 2-2

DIRECT CURRENT VOLTAGE GRADIENT SURVEYS (DCVG)

Direct current voltage gradient (DCVG) surveys are used to evaluate the coating condition on buried pipelines. Voltage gradients arise as a result of current pickup or discharge at coating holidays. In a DCVG survey, the DC signal is created by interrupting the pipeline's CP current or a temporary CP current, and the voltage gradient in the soil above the pipeline is measured. Voltage gradients are located by a change in the interrupted signal strength at grade.

DCVG is the only method that can be used to approximate the size of a coating holiday. DCVG signal strength is not always proportional to holiday size, as the orientation of the holiday and other factors affect the measured signal.

DCVG surveys are capable of distinguishing between isolated and continuous coating damage. The shape of the gradient field surrounding a holiday provides this information. Isolated holidays, such as rock damage, produce fairly concentric gradient patterns in the soil. Continuous coating damage, such as disbanded coatings or cracking, produces elongated patterns.

The DCVG system consists of a current interrupter, an analog or digital voltmeter, connection cables, and two probes with electrodes filled with water. The interrupter is used to interrupt current from an existing rectifier unit, galvanic anode system, or a temporary CP system installed for the purpose of the DCVG survey.

An analog voltmeter must have a needle with the ability to deflect in both the positive and negative directions from the zero point, which assists in determining the direction the current is flowing in the soil. Digital voltmeters must be sufficiently sensitive to measure 1 mV changes between the two reference probes and have the ability to indicate the direction of current flow in the soil. The voltmeter should have the ability to adjust the input impedance for use in high

resistance contact situations.

The current interrupter is installed in series with the current source and set to cycle at a fast rate with the "on" period less than the "off" period. A common interruption cycle is 0.3 seconds on and 0.7 seconds off. This short cycle allows for a quick deflection by the analog voltmeter needle.

DCVG surveys can be performed with impressed current CP systems energized. Sacrificial anodes and bonds that are not disconnected show up as anomalies. Sacrificial anodes and bonds to other structures are usually disconnected to prevent signal loss and enhance current flow down the pipeline under investigation.

The IR drop is measured at the test stations in the proximity of the DCVG survey. It is desirable to have a minimum of 100 to 400 mV of IR drop in soil environments and more IR drop when surveying on asphalt/concrete, in the section of pipeline to be surveyed. If at the estimated daily survey section limits there is not a 100 to 400 mV IR drop, then the current output of the CP current source should be increased to achieve the desired result. If the output cannot be increased, then the section of pipe with the 100 to 400 mV IR drop is the only section that can be surveyed using that CP current source. Alternative CP current sources may need to be temporarily installed in order to achieve the desired IR drop. It is desirable to have as large an IR drop value as can be achieved. This will enable the surveyor to detect small holidays distant from the CP current source.

A surveyor walks along the pipeline such that the probes can be used in a walking stick fashion. One probe is always kept near the pipeline center line while the other is held approximately five (5) feet away perpendicular to the pipe. The voltmeter is read when both probes are in contact with the soil.

If possible, the pipeline under investigation should be electrically isolated from other



ANALOG DCVG METER

FIGURE 2-3



**DCVG SURVEYOR MEASURING VOLTAGE GRADIENT
ABOVE PIPELINE**

FIGURE 2-4



DCVG SURVEY COMPLETED ON WET ASPHALT IN MAJOR CITY

FIGURE 2-5

parallel metallic structures by disconnecting electrical bonds, negative drains to rectifiers, etc. In pipeline right of ways with multiple electrically continuous pipelines or metallic conduits/structures, variations in the survey technique must be considered. For example, if parallel pipelines (metallic structures) are less than ten (10) feet from the pipeline under investigation, then the perpendicular probe should be placed at half the distance between the two pipelines, however, difficulties may be encountered with current flow to the parallel metallic structure. The perpendicular probe must be placed on the side of the investigated pipeline without a parallel pipeline (metallic structure). If the pipeline under investigation has pipelines (metallic structures) on either side, then the probe should be placed perpendicular, but not above or in close proximity to the parallel pipeline (metallic structures).

If the voltmeter indicates a coating holiday, additional measurements should be made to confirm the coating holiday is on the pipeline under investigation and not the parallel pipeline. These tests include gradient measurements on both sides of the pipeline and parallel with the pipeline under investigation to confirm the coating holiday location.

When parallel metallic structures or right of way conditions do not allow sufficient room for placement of the probe to the side of the pipeline, an alternate method of DCVG can be conducted. Place both probes directly above the pipe centerline approximately five to ten feet apart from one another and measure the voltage gradient in this manner. Leap frog the rear probe to the forward position and repeat the process continuing along the right of way directly above the pipe. Care must be taken to pinpoint the maximum deflection or indication when completing the survey in this manner. The exact location of the indication requires moving the probes at closer spacings once the coating holiday is detected.

When a coating holiday is approached, a noticeable signal swing can be observed on the

voltmeter at the same rate as the interrupter switching cycle. The amplitude of the swing increases as the coating holiday is approached and decreases after it has been passed. Current flow from the interrupted current source to the pipeline indicates a possible coating holiday while current flow away from the pipeline indicates current flow past the pipeline.

When a coating holiday is found, additional gradient measurements can be beneficial to confirm its location and that the indication is not current traveling past the pipeline. These gradient measurements can be made on both sides of the pipe and parallel with the pipe on each side of the assumed coating holiday.

A straight-line attenuation effect is assumed between test station locations to calculate the signal strength at intermediate coating holiday locations. In order to calculate the coating holiday size (%IR), the difference between the on and off potentials at each test station, valve, or other above grade appurtenance must be measured and recorded.

One reference electrode is placed at the base of the test station or other electrical contact point, in contact with the soil while the second electrode porous tip contacts the test station wire or other properly cleaned electrical contact point. The maximum analog needle deflection is the test station IR drop or difference between the on and off potentials when using a digital voltmeter.

The distance between test stations or points of electrical contact must be determined from the pipeline stationing and used in the calculations for the signal attenuation.

An example of the attenuation calculations can be seen below:

$$\text{On potential} = -1.45 \text{ V}$$

$$\text{Off potential} = -0.95 \text{ V}$$

$$\begin{aligned} \text{Signal Strength} &= 1.45 - 0.95 \text{ V} \\ &= 0.5 \text{ V or } 500 \text{ mV} \end{aligned}$$

The estimated signal strength can be exemplified by using the data presented in Figure 2-6.

Estimated signal strength at defect:

$$\begin{aligned}
 &= 200 \text{ mV} + \left[\frac{1500}{500 + 1500} (300 - 200) \right] \text{ mV} \\
 &= 200 \text{ mV} + 75 \text{ mV} \\
 &= 275 \text{ mV}
 \end{aligned}$$

Precisely locating a coating holiday is achieved by marking the approximate location of the holiday at the area where the maximum amplitude is indicated. Near the approximate coating holiday location and offset from the line by approximately 10 ft, the probes are placed along the voltage gradient to obtain a null (zero) on the meter. A right-angle line through the center of the probe locations passes over the coating holiday epicenter, as shown in point A in Figure 2-7. This geometrical procedure repeated on opposite sides of the pipeline locates the exact point above the holiday.

A survey flag, wooden stake, paint mark, or lathe is often placed at the indication epicenter and identified by a unique indication number using a permanent marker or paint.

After the epicenter of the coating holiday has been detected, a series of continuous lateral (perpendicular) readings are measured moving toward remote earth. Lateral readings near the holiday yield maximum voltage differences where gradients are at a maximum. Readings at remote earth are considered to be achieved when one has a 1 mV deflection. The summation of these readings is commonly referred to as the over-the-line-to-remote-earth voltage. The expression “percentage IR” has been adopted to give a relative indication size.

For instance, if a series of lateral millivolt readings to remote earth are as follows, 25, 15, 6, 4, 3, 1, 1, 0, the percentage IR can be calculated as follows:

$$\begin{aligned}
 \text{Over the line to remote earth voltages} &= 25 + 15 + 6 + 4 + 3 + 1 + 1 \text{ mV} \\
 &= 55 \text{ mV}
 \end{aligned}$$

$$\begin{aligned}
 \text{Percentage IR} &= \frac{\text{Over the line to remote earth voltage} * 100\%}{\text{Signal Strength}} \\
 &= \frac{55 * 100}{275} \\
 &= 20\%
 \end{aligned}$$

The percentage IR is used to develop a coating condition classification system to prioritize coating damage.

Once an indication is located, its size or severity is estimated by measuring the potential lost from the holiday epicenter to remote earth. This potential difference is expressed as a fraction of the total potential shift on the pipeline (the difference between the “on” and “off” potential, also known as the IR drop) resulting in a value termed % IR. DCVG survey readings can be broken into four groups based on approximate size as follows:

Category 1: 1% to 15% IR - Indications in this category are often considered of low importance. A properly maintained CP system generally provides effective long-term protection to these areas of exposed steel.

Category 2: 16% to 35% IR - These indications are generally considered of no serious threat and are likely to be adequately protected by a properly maintained CP system. This type of indication may be slated for additional monitoring. Fluctuations in the levels of protection could alter the status at these points as the coating further degrades.

Category 3: 36% to 60% IR - The amount of exposed steel in such an indication indicates it may be a major consumer of protective CP current and that serious coating damage may be present. As in Category 2 indications, this type of possible coating holiday may be slated for monitoring as fluctuations in the levels of CP could alter the status as the coating further degrades.

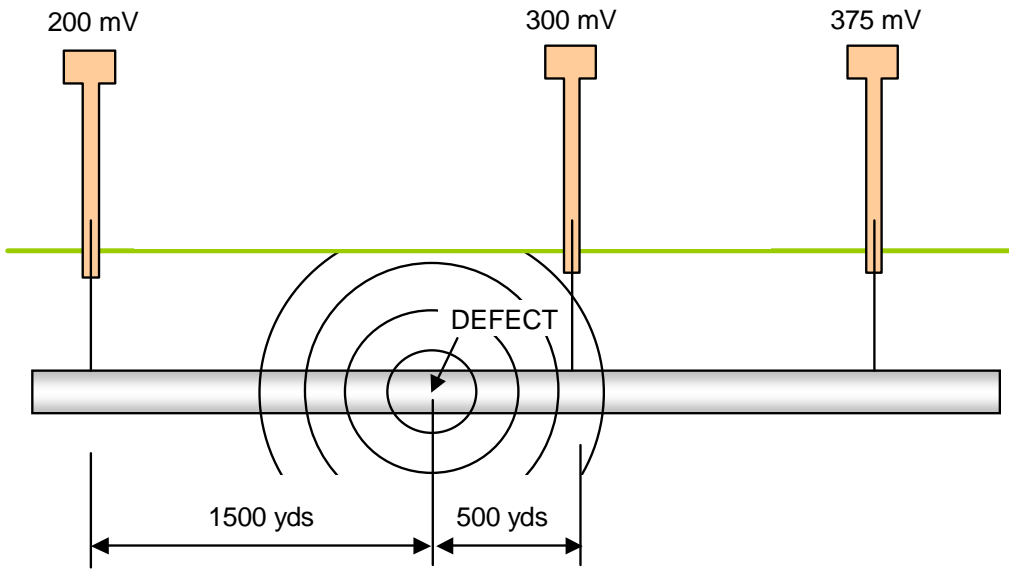

DCVG SIGNAL STRENGTH

FIGURE 2-6

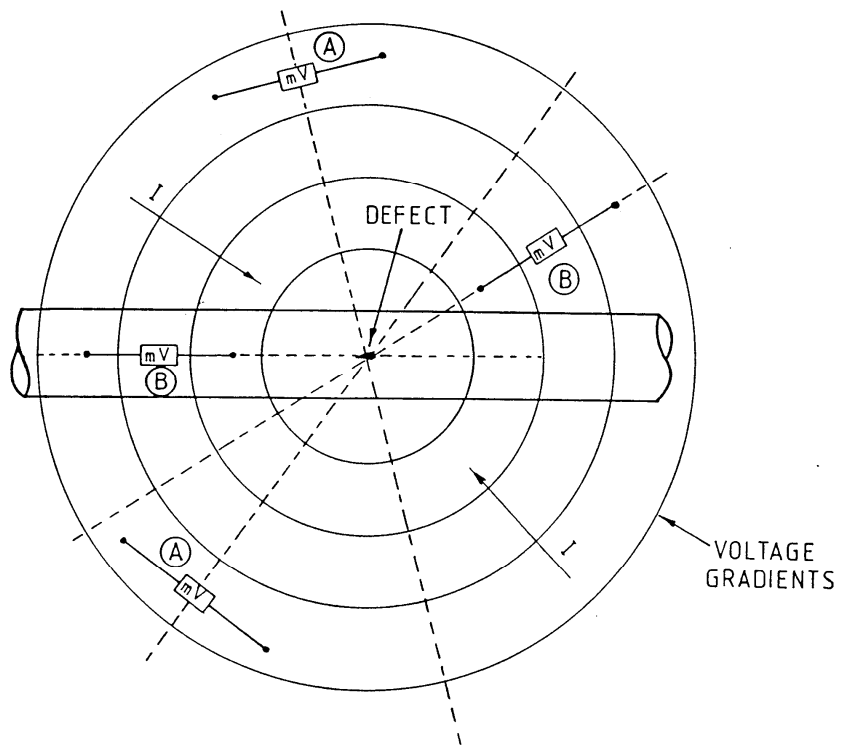

DCVG VOLTAGE GRADIENTS

FIGURE 2-7

Category 4: 61% to 100% IR - The amount of exposed steel indicates that this indication is a major consumer of protective CP current and that massive coating damage may be present. Category 4 indications typically indicate the potential for serious problems with the coating.

These example categories are empirical in nature and are based on the results of prior exploratory excavations at holiday locations determined by DCVG surveys.

ALTERNATING CURRENT VOLTAGE GRADIENT SURVEYS (ACVG)

Alternating current voltage gradient (ACVG) surveys are used to evaluate the coating condition on buried pipelines. Voltage gradients arise as a result of current pickup or discharge at coating holidays. In an ACGV survey, the AC signal is created by a low frequency transmitter connected to the pipeline and the voltage gradient in the soil above the pipeline is measured. Voltage gradients are located by a change in the signal strength at grade.

ACVG signal strength is not always proportional to holiday size, as the orientation of the holiday and other factors affect the measured signal.

ACVG surveys are capable of distinguishing between isolated and continuous coating damage. The shape of the gradient field surrounding a holiday provides this information. Isolated holidays, such as rock damage, produce fairly concentric gradient patterns in the soil. Continuous coating damage, such as disbanded coatings or cracking, produces elongated patterns.

The ACGV system consists of a commonly employed, commercially available battery/AC powered signal-generating unit that provides a 937.5-Hz AC signal with a maximum output of 750 mA or a 4-Hz AC signal with a maximum output of three amperes. A handheld receiver unit is tuned to detect the signal frequency from the transmitter and block other signals. There are two probes which connect to the receiver and are in contact with the soil.

An AC current attenuation survey may be performed with impressed current CP systems energized, however by turning off the rectifier and using the positive and negative leads at the rectifier station, the signal-generation capabilities of the equipment can be maximized. Sacrificial anodes and bonds that are not disconnected show up as anomalies. Sacrificial anodes and bonds to other structures are usually disconnected to prevent signal loss and enhance current flow down the pipeline.

The signal generator (transmitter) is connected to the pipeline and appropriately grounded to earth. A constant AC signal is produced and transmitted along the pipe. The transmitter is energized and adjusted to an appropriate output. Typically, the largest attainable current output is chosen to maximize the length of pipe that can be surveyed. An impressed current anode bed or magnesium anode can be used to establish an electrical ground.

The receiver consists of a handheld, symmetrical, multi-axis antenna array. The electromagnetic field radiating from the pipeline is measured by the detector.

The detector is used to measure the attenuation of the signal current that has been applied to the pipe. An electrical current, when applied to a well coated buried pipeline, gradually decreases as distance increases from the point of current application. The electrical resistivity of the coating under test and the surface area in contact with the soil per unit length of pipe are the primary factors affecting the rate of decline and the frequency of the signal.

The two probes must be connected to the receiver unit and plugged in. Survey intervals should be no greater than ten (10) feet in those areas deemed to have coating holidays.

The operator walks above the pipeline centerline placing the contact probes into the soil above the pipe and measuring the voltage gradient and direction. Probes are placed parallel to the pipe. The receiver unit will "point" in the direction of a coating holiday. The



ACVG SURVEY ABOVE PIPELINE LOCATING COATING HOLIDAYS

FIGURE 2-8

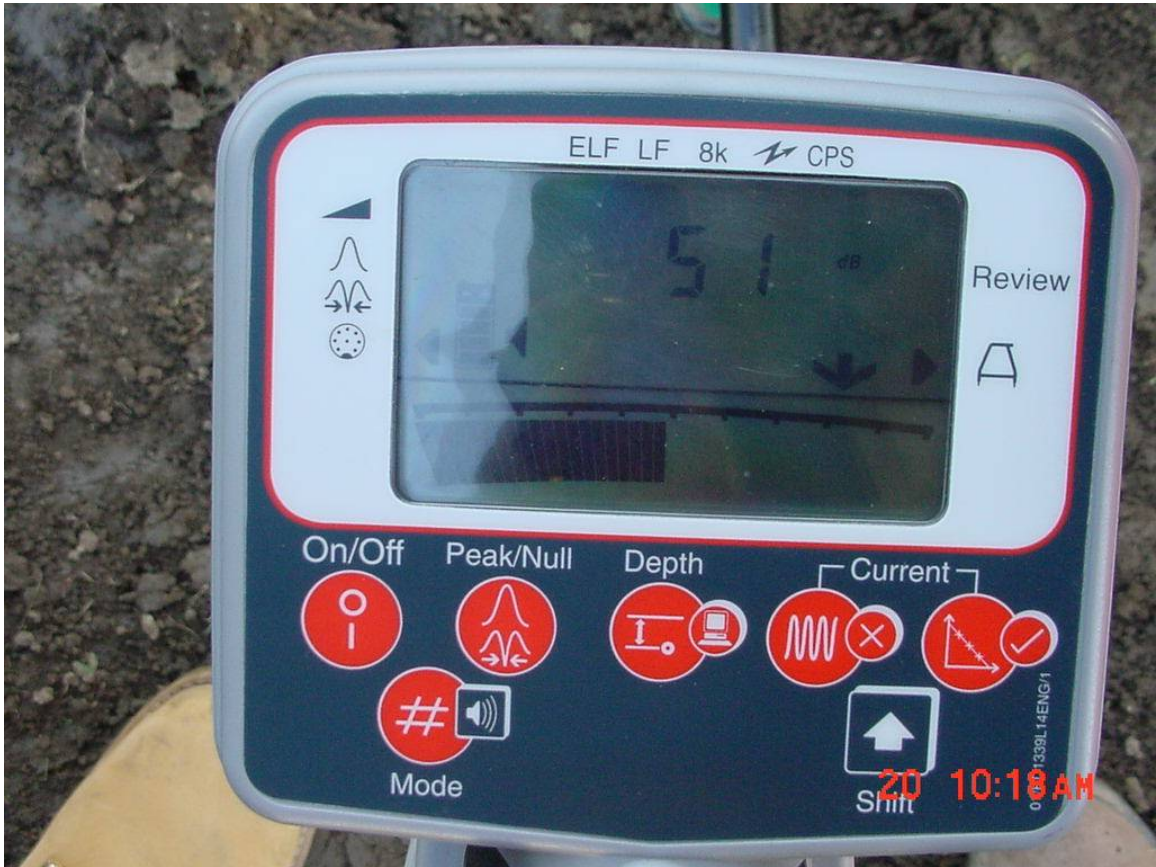

AC CURRENT ATTENUATION RECEIVER FACE

FIGURE 2-9

magnitude will increase as the holiday is approached.

The survey continues until the receiver indicates that the coating holiday has been passed (signal magnitude decreases and direction arrow reverses direction) at which point the operator reverses direction and shortens the interval between readings.

When the holiday is centered between the two probes, the magnitude will be zero and the direction arrows will not indicate a consistent current direction.

The probe assembly can be used to the side of the pipe (perpendicular to the pipe) to confirm the coating indication location. The holiday location is indicated by the maximum signal magnitude with the probes placed perpendicular to the pipe.

Either store the data in the receiver unit or record the information in the project field book.

CLOSE-INTERVAL SURVEYS (CIS)

CIS is used to measure the potential difference between the pipe and the electrolyte. Data from close interval surveys are used to assess the performance and operation of the CP system. CIS can also be used to detect coating holidays.

While other indirect inspection tools may be better suited to detect coating holidays, CIS also aid in identifying:

1. Interference,
2. Shorted casings,
3. Areas of electrical or geologic current shielding,
4. Contact with other metallic structures, and
5. Defective electrical isolation joints.

On and off potential surveys are used to

evaluate CP system performance in accordance with the NACE pipeline CP criteria as found in SP0169. On and Off surveys measure the potential difference between the pipe and the electrolyte as the CP current source(s) is switched on and off.

On and Off surveys rely on electronically synchronized current interrupters at each CP current source, bond, and other current drain point that influences the pipeline potential in the survey area. The ratio of the On-to-Off interruption cycle should be long enough for readings to be made but short enough to avoid significant depolarization. A three second On, one second Off cycle period or similar can be used to maintain pipeline polarization over time and allow accurate Off potentials to be recorded.

The copper sulfate reference electrodes (CSE) are placed directly over the pipeline, typically at 2.5 to 5 foot intervals such that both On and Off potentials can be measured and recorded at each reference cell location.

The accuracy of the on and off data can be verified by recording a continuous datalog (waveprint) at test stations or points of electrical contact such as valves or risers. This data log will illustrate proper interrupter synchronization and the effects of pipeline depolarization during the survey should it take place. The continuous data log should measure and store the potentials at a minimum time period as the total current interruption cycle. Waveprints can also be reviewed to confirm the point at which the Off potential should be recorded by the CIS datalogger. In addition, the waveprints can be analyzed to determine the affects of:

Inductive potential spiking,

Interrupter synchronization drift,

Stray DC and AC earth currents.

CIS equipment includes, at a minimum, several high input impedance data loggers/voltmeters, sufficient current interrupters for the project,



**CLOSE-INTERVAL SURVEY TECHNICIAN WITH DATALOGGER,
REFERENCE ELECTRODE, AND WIRE DISPENSERS**

FIGURE 2-10

copper sulfate reference electrodes, small gauge CIS wire (30 AWG), wire dispenser, and pipe/cable locating equipment (See above section on pipe locating).

Standard current interrupter units include 30, 60, or 100 ampere AC and DC interruption capacity, AC or battery-powered units, with electronic synchronization and Global Position Satellite (GPS) timing.

Prior to the CIS, a rectifier influence survey may be completed to determine the CP current sources which must be interrupted for the accurate measuring of Off potentials. These include company rectifiers, galvanic anode systems, foreign company rectifiers, and electrical bonds to foreign company structures. Individually, each CP current source should be tested. A current interrupter is used to interrupt the CP current source suspected of influencing the CIS pipeline segment. Typically, a slow interruption cycle is used such as a ten second On, five second Off period. Pipe-to-electrolyte potentials are measured at the furthest test points suspected of influence from the suspect CP current source.

Test points are monitored moving away from the suspect CP current source. Once a 10 mV or less difference between On and Off pipe to electrolyte potential is observed, the influence of the CP current source is deemed no longer significant for analysis of the pipe CP levels.

Several test points beyond the location where the influence of the CP current source is deemed to terminate should be tested to confirm the end of the influence from the suspect CP current source.

To start the CIS, a current interrupter is installed in series in either the AC or DC circuits of all of the current sources in the CP current sources identified. Current interrupters maintain interruption synchronization. All interrupters must be synchronized together. Interrupters should be programmed such that they are interrupting no longer than the anticipated survey duration each day. When no field

surveying is taking place, the interrupters should be programmed to turn off in order to minimize the affects of depolarization.

A 30, 32, or 34 AWG gauge insulated wire is electrically connected to a test station test wire, valve, or other electrically continuous pipeline appurtenance and one terminal of the voltmeter. The other terminal of the voltmeter is attached to the reference electrode.

The pipeline is located with a pipe locator prior to collecting data to ensure that the reference electrode is placed directly over the pipeline (See Pipe Locating Section).

Industry standard copper sulfate reference electrodes (CSE) should be used for potential measurements. See NACE Standard TM0497. Reference electrodes should be calibrated with an unused control reference electrode daily, the results of which should be recorded in the project field book. The control reference electrode should be a recently charged electrode not used to gather data in the field. To calibrate the CSE, the ceramic porous electrode tips are placed tip to tip to measure the voltage difference between the two electrodes or both tips are immersed in a container of potable water. A digital voltmeter on the millivolt scale is used to measure the voltage difference. If the voltage difference between the two electrodes exceeds 5 mV, the field electrode should be emptied, cleaned properly, and recharged with unused distilled water and copper sulfate crystals. If the voltage difference remains greater than 5 mV, the field electrode should be disposed of properly and not used to collect data.

A datalogger can be placed at the suspected midpoint of each day's CIS progress for later analysis of the CIS data. The datalogger should measure and record the pipe-to-electrolyte potential continuously during each day's survey. The datalogger should be programmed to record the pipe potential at a rate of one reading per second or greater. The datalogger should be installed and turned on prior to the start of CIS each day and should run until after

the completion of CIS each day. The data can be retrieved from the datalogger each day and analyzed for the existence of dynamic stray currents, de-energizing of a CP source, or improper current interrupter operation.

On and Off pipe-to-electrolyte potentials are then measured and recorded typically at 2.5 to 5 foot intervals using a high-input impedance voltmeter/datalogger. The datalogger should have the ability to adjust the time during the Off cycle at which the handheld datalogger stores the Off potential value due to the possibility of inductive/capacitive spiking. The datalogger should be programmed such that the On and Off pipe to electrolyte potentials are measured and stored from a time period beyond the spiking as determined by the waveprints discussed above.

Pipe-to-electrolyte potential measurements should be measured and recorded at each test station and foreign pipeline crossing from each test wire within accessible test stations. Near ground (NG), metallic IR Drop (IR), and far ground (FG) On and Off pipe-to-electrolyte potential measurements should be made at each point of pipeline connection.

If the Off metallic IR drop exceeds 5 mV, the survey should be halted and an investigation made to determine the source of the error. Possible sources for this error include interrupter malfunction, stray currents, and unknown foreign rectifiers or electrical bonds.

AC pipe to electrolyte potentials can be measured at each point of pipeline connection and recorded in the project field book or within the CIS data stream.

On and Off casing to electrolyte potentials should be measured at each casing, either by monitoring the test wire attached directly to the casing pipe or by temporary electrical connection to the casing vent.

When a stationing flag is encountered, a flag comment or code is entered into the data logger for later computer graphing and stationing

purposes. When a numbered flag is encountered, the flag number can also be entered into the data stream.

All permanent landmarks should be identified and entered into the data logger during the survey. These include pipeline markers, test points, fences, casing vents, creeks, and road names.

Upon completion of the survey, all CIS wire should be retrieved. Flags can be left in place until the final ECDA process/surveys are completed and deemed appropriate for final removal.

AC CURRENT ATTENUATION SURVEYS (ELECTROMAGNETIC)

AC current attenuation surveys are used to provide an assessment of the overall quality of the pipe coating within a section or as a comparison of several sections. A current is applied to the pipeline, and coating damage is located and prioritized according to the magnitude and change of current attenuation. AC current attenuation surveys may be performed with impressed current CP systems energized, however by turning off the rectifier and using the positive and negative leads at the rectifier station, signal-generation capabilities of the equipment can be maximized. Sacrificial anodes and bonds that are not disconnected show up as anomalies. Sacrificial anodes and bonds to other structures are usually disconnected to prevent signal loss and enhance current flow down the pipeline.

Commonly employed, commercially available battery-powered signal-generating units include units that provide a 937.5-Hz AC signal with a maximum output of 750 mA or a 4-Hz AC signal with a maximum output of three amperes. A handheld receiver unit tuned to detect the signal from the transmitter and block other signals is used to pick up the signal.

The signal generator is connected to the pipeline and appropriately grounded to earth. A constant AC signal is produced and transmitted



AC CURRENT ATTENUATION TRANSMITTER

FIGURE 2-11



**TECHNICIAN MEASURING AC CURRENT ATTENUATION
WITH RECEIVER**

FIGURE 2-12

along the pipe. The transmitter is energized and adjusted to an appropriate output. Typically, the largest attainable current output is chosen to maximize the length of pipe that can be surveyed. An impressed current anode bed or magnesium anode can be used to establish an electrical ground. If operating rectifiers are interfering with the signal, then turn the units off.

Signals are measured using the receiver unit. The receiver consists of a handheld, symmetrical, multi-axis antenna array. The electromagnetic field radiating from the pipeline is measured by the detector. The detector is used to measure the attenuation of a signal current that has been applied to the pipe. An electrical current, when applied to a well-coated buried pipeline, gradually decreases as distance increases from the point of current application. The electrical resistivity of the coating under test and the surface area in contact with the soil per unit length of pipe are the primary factors affecting the rate of decline and the frequency of the signal.

The logarithmic rate of decline of the current (attenuation), which is effectively independent of the applied current and marginally affected by seasonal changes in soil resistivity, provides an indication of the average condition of the pipe coating between two given points on the date of the survey. Changes in attenuation provide a comparative change in coating condition between survey sections. Such comparative changes can indicate “better” coating (i.e., fewer anomalies or a small single anomaly) or “worse” coating (i.e., more anomalies or a larger single anomaly).

Survey intervals are typically 100 feet at the pipeline locating flags. The measured current value is recorded in the project field book or the transmitter for later analysis. The receiving unit must remain upright and perpendicular to the pipe when taking the measurements. When readings are suspect, stay on peak mode and check both the peak and null readings and verify pipe depth. Take multiple readings in one location if data accuracy is questionable. The

accuracy of the readings may be affected by distortions in the AC signal caused by other underground piping and conduits, traffic control signaling, or vibrations due to passing vehicles.

Survey data are analyzed after the survey to determine which survey intervals exhibit reduced coating quality.

SUMMARY

The indirect above ground inspection techniques discussed in this chapter are used to identify and define coating faults and in turn those areas where corrosion activity may have occurred or may be occurring. Two or more of these inspection techniques should be used when conducting this indirect inspection testing so that different types of data can be compared and analyzed to determine whether there is any correlation. The effectiveness of the testing techniques employed will depend on factors such as operator experience, pipeline/coating/CP circuit conditions, depth of pipe, and type of cover at grade.

Should significant coating damage be indicated from these tests, the pipeline should be excavated and examined for possible corrosion damage and the appropriate remedial actions should be taken.

ACKNOWLEDGMENT

This chapter was written by Kevin T. Parker and was edited by the AUCSC Curriculum Committee.

CHAPTER 3

MATERIALS FOR CATHODIC PROTECTION

INTRODUCTION

This chapter will discuss common materials used for underground cathodic protection installations. Some of the materials have established track records and some are new with very little known about the long term life effects in a particular environment. For our purposes, we will define "long term" as any material with a successful application record in underground use of more than 20 years.

Knowledgeable persons in the corrosion control industry must have a grasp of the advantages and limitations of a product and how the product relates to any given application. Furthermore, they must be able to convey in writing, the specifics of how the product is to be manufactured or supplied to assure that it will conform to predetermined design life criteria. The object of this chapter is to fit the right type of materials with the structure to be protected at the lowest possible cost per year of predetermined service life.

CONSIDERATIONS FOR ALL MATERIALS

Material must be selected for each application with the following interrelated items considered:

1. Design criteria
2. Life required
3. Capacity or rating of material selected
4. Economics
5. Environment - both underground and above grade

Specifying materials, when requisitioning or purchasing, the following should be checked:

1. Specify materials completely.
2. Make sure that complete specifications are on the purchase order.
3. Check material received to ensure that it conforms to the original specifications.

Usage:

1. Follow the manufacturer's recommendations and instructions.
2. Use compatible components.
3. Use the proper tools.
4. When a problem or question arises, ask the manufacturer or distributor for assistance.

GALVANIC ANODES

Galvanic anodes consist primarily of magnesium, zinc, and aluminum, with each type having different metallurgical compositions within each metal group. These subtle differences in metallurgy can have a profound effect on the long term operational characteristics of the system. A successful galvanic system must have a more negative potential than the structure it is designed to protect. This is referred to as the driving potential difference and is controlled by the negative electrical values of each metal in a given environment and affected by the resistance of the electrolyte through which the current, generated by the anode, must flow. Anode driving potential is not affected by resistance of electrolyte. Figure 3-1 shows a

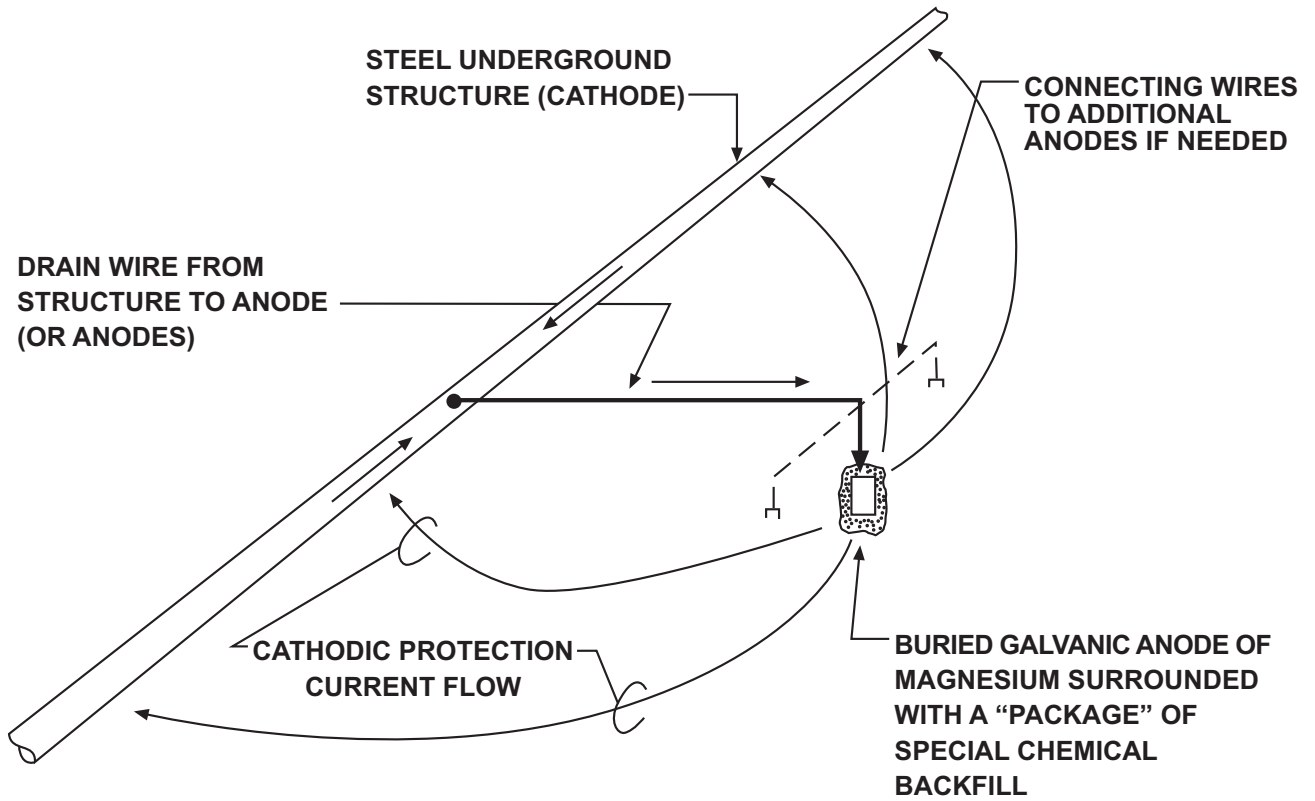

TYPICAL GALVANIC ANODE INSTALLATION

FIGURE 3-1

schematic diagram of a typical galvanic anode installation.

Table 3-1 shows the metals used for galvanic anodes, the alloys of each metal, the open circuit potential, and the number of ampere hours of capacity per pound of metal for each type. Impurities and grain size will cause wide ranges in potential, current efficiency values, and consumption rates, which are expressed in pounds per ampere year (lb/A-y).

These are representative values derived from literature provided by various manufacturers. In most cases, magnesium is preferred for soils and fresh water. Zinc is generally limited to use in sea water, brackish water, sea mud, and soils with resistivities below 1,500 ohm-cm. Aluminum is generally limited to sea water, brackish water, and sea mud environments.

The important point to consider for maximum service life is the cost per ampere hours of current capacity, once it has been established that the driving potential is sufficient for the cathode metal and the resistivity of the electrolyte in the circuit. When working in the higher resistivity soils, long slender anodes have a lower resistance to earth than the shorter anodes which are available. This means that the circuit resistance for the limited driving voltage available from a galvanic anode will be less, and as a result, more current output will be obtained. To say it in another way, the same amount of anode material (such as a 20 lb. magnesium anode) in a given soil resistivity environment will produce more current if it has been cast in a long, slender shape than it will if cast in a short and more stocky shape. This will result in the longer shaped anode having a shorter life expectancy - although this "shorter" life expectancy may be fully adequate for applications in higher resistivity soils. The anode installation design for a particular situation will take the resistivity of the environment into account and will balance current requirements against desired life to determine the size, number, and weight of anodes needed.

Prepared Backfill and Packaging

Most magnesium and zinc anodes used in soils require the use of a prepared backfill around the anode for the following reasons:

- It increases the effective surface area which lowers the anode to earth contact resistance.
- The bentonite clay absorbs and retains moisture.
- The gypsum provides a uniform, low resistance environment.
- The sodium sulfate (a depolarizing agent) minimizes pitting attack and oxide film formation on the anode.
- It provides uniform environment directly in contact with anode to assure even consumption.

Today, the most commonly used backfill for magnesium and zinc consists of:

75% Hydrated Gypsum ($\text{CaSO}_4 \cdot 2\text{H}_2\text{O}$)
20% Bentonite Clay
5% Sodium Sulfate

When properly combined, these elements will provide a uniform resistance of 50 ohm-cm backfill when measured by the ASTM G-58 Soil Box Test Method and corrected for temperature variations. Most reputable anode fabricators will test and document the resistance values for each batch of backfill. As a historical side note, zinc was formerly thought to perform better in a backfill of 50% gypsum and 50% bentonite. Over the years it has been determined that zinc may passivate if sodium sulfate is not used in the backfill.

To keep the backfill uniformly around the anode, the anodes with the lead wire attached are placed in cloth bags or cardboard boxes and the prepared backfill is then added. Cloth bagged anodes are usually encased within a layered paper bag for resistance to short

TABLE 3-1

Capabilities and Consumption Rates

Type	Potential* (- volts)	Amp Hours per lb.	Consumption (lb/A-yr)
Magnesium			
H-1 AZ-63 Alloy	1.4 - 1.5	250 - 470	19 - 36
High Potential Alloy	1.7 - 1.8	450 - 540	16 - 19
Zinc			
ASTM B418-01			
Type I (saltwater)	1.1	354	24.8
Type II (soil)	1.1	335	26.2
Aluminum			
Mercury Alloys	1.10	1250 - 1290	6.8 - 7.0
Indium Alloys	1.15	1040 - 1180	7.4 - 8.4

* Copper/Copper Sulfate Reference Electrode - Open circuit practical values as shown

periods of inclement weather and handling damage. Prior to backfilling, the paper bag is removed and discarded, permitting the cloth bag containing the backfill to absorb moisture, allowing the anode to start putting out current soon after installation. During transportation and/or handling the anodes may shift in the prepared backfill. This may result in uneven consumption of the anode, reduction of current output and premature failure of the anode. This condition should be avoided by careful specification of transportation packaging and field handling precautions. Anodes packaged in cardboard boxes or bags with centralizing devices may tend to reduce anode shifting.

Wire and Cable Attachment

Wire used to connect the anode to the structure is usually a No. 12 AWG solid copper, single conductor, with TW (30 mils PVC), THW (45 mils PVC), or THHN insulation.

THHN is a new insulation for anode use and short term accelerated testing has found, that under normal current flow conditions, it will provide satisfactory performances. It uses a 15 mil PVC insulation jacketed with 4 mils of nylon, but no field testing has been done to determine if the reduced PVC thickness will handle fault current and lightning surges. It is known that nylon absorbs moisture and eventually breaks down when subjected to immersion in water.

Proper attachment of the wire or cable to the anode core is critical for two reasons. First, the connection must be electrically sound to minimize internal resistance; second, it must also be strong enough to support the weight of the packaged anode if it is lifted by the lead wire. The lead wire is usually silver soldered to the core with a 50% silver, 50% tin compound. Next, the connection must be primed and covered with an inert thermoplastic electrical potting compound to prevent water migration to the connection.

When anodes are used as grounding cells, and are required to carry more amperes of current, the cable may be larger (i.e., No. 8 AWG, No. 6

AWG, or No. 2 AWG stranded, single conductor with high molecular weight polyethylene (HMWPE) insulation).

Zinc anodes do not have a recessed core, so the cable should be crimped and silver soldered to the extended rod core and coated with a piece of heat shrinkable polyethylene tubing or several laps of electrical tape to protect the connection.

Magnesium Alloys

Magnesium anodes are produced in a wide variety of sizes and shapes to fit design parameters. They may be cast in molds or extruded into ribbon or rod shapes, with steel spring, perforated strap or wire cores as shown in Figure 3-2. The core is important because it should extend 85 percent or more through the anode to reduce the internal circuit resistance. Table 3-2 shows some of the common weights and corresponding dimensions for bare and packaged anodes. Chemical composition is shown in Table 3-3.

Several alloys are available and their respective potential values will be an important part of the calculations for a cathodic protection design based on driving potential and current efficiency (See Table 3-3). Design of galvanic cathodic protection systems is covered in Chapter 6.

Element	Effects*
Aluminum	Properties of H-1 (AZ-63) alloys are not affected by variations between 5 - 7%; high potential alloy current capacity is decreased if aluminum is >0.01%.
Zinc	Current capacity of H-1 and AZ-63 is slightly decreased if >3.0%.
Manganese	The detrimental effect of iron on current capacity of all magnesium alloys is offset by adding manganese. The

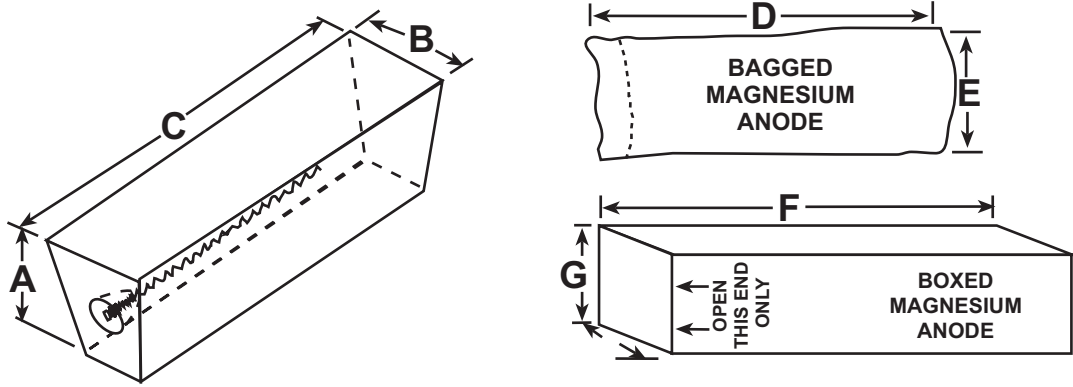

BARE AND PACKAGED MAGNESIUM ANODES

FIGURE 3-2

TABLE 3-2**Magnesium Anode Dimensions and Weights**

Nominal Dimensions (Inches) - See Figure 3-2								
Alloy	A	B	C	D	E	F	G	Packaged Weight (lbs)
1 AZ63	3.2	Rd	2	6	6	-	-	3.6
3 H.P./AZ63	3	3	6	8	6	-	-	9
5 H.P./AZ63	3	3	10	12	5	-	-	12
6 H.P./AZ63	3	3	10	-	-	12.5	5	14
9 H.P./AZ63	3	3	13.5	17	6	-	-	27
12 AZ63	4	4	12	18	7.5	-	-	32
17 H.P.	3.5	3.5	25.5	30	6	-	-	42
17 AZ63	3.5	3.5	28	-	-	32	5.5	45
20 H.P.	2	2	60	-	-	71	4.5	65
32 H.P./AZ63	5.5	5.5	21	25	8	-	-	72
32 H.P./AZ63	5.5	5.5	21	-	-	24	7.5	70
40 H.P.	3.5	3.5	60	64	6	-	-	105
48 H.P.	5.5	5.5	32	36	8	-	-	106
50 AZ63	7	7	15	24	10	-	-	110
60 H.P.	4	4	60	64	5.75	-	-	130

Magnesium Extruded Ribbon and Rods

Size (Inches)	Weight (lb/ft)	Core (Inches)
$\frac{3}{8} \times \frac{3}{4}$	0.24	0.125
0.750	0.36	0.125
0.840	0.45	0.125
1.050	0.68	0.125
1.315	1.06	0.125
1.561	1.50	0.125
2.024	2.50	0.125

* Data were compiled from literature provided by various vendors and may vary slightly.

TABLE 3-3**Composition of Magnesium Alloy**

Element	AZ63B (H1A)	AZ63C (H1B)	AZ63D (H1C)	M1C (High Potential)
Aluminum (Al)	5.3 - 6.7%	5.3 - 6.7%	5.0 - 7.0%	< 0.01%
Zinc (Zn)	2.5 - 3.5%	2.5 - 3.5%	2.0 - 4.0%	-
Manganese (Mn)	0.15 - 0.7%	0.15 - 0.7%	0.15 - 0.7%	0.5 - 1.3%
Silicon (Si)	< 0.10%	< 0.30%	< 0.30%	< 0.05%
Copper (Cu)	< 0.02%	< 0.05%	< 0.10%	< 0.02%
Nickel (Ni)	< 0.002%	< 0.003%	< 0.003%	< 0.001%
Iron (Fe)	< 0.003%	< 0.003%	< 0.003%	< 0.03%
Others (each)	-	-	-	< 0.05%
Others (total)	< 0.30%	< 0.30%	< 0.30%	< 0.30%
Magnesium (Mg)	Balance	Balance	Balance	Balance

Performance Characteristics*

	AZ63B (H1A)	AZ63C (H1B)	AZ63D (H1C)	M1C (HP)
Potential (Volts to Cu/CuSO ₄)	-1.60	-1.55	> -1.40	-1.75
Theoretical Amp-hours/lb	1000	1000	1000	1000
Actual Amp-hours/lb	450 - 580	300 - 470	250 - 470	400 - 540
Current Efficiency (%)	45 - 58	30 - 47	25 - 47	40 - 54
Actual Consumption (lb/A-yr)	18 - 15	33 - 19	35 - 19	19 - 16

* Using ASTM Standard G97-97 "Standard Test Method for Laboratory Evaluation of Magnesium Sacrificial Anode Test Specimens for Underground Applications".

	manganese surrounds the iron particles and decreases their local cathodic effect.
Iron	Detrimental to current capacity; controlled by adding manganese in molten state.
Silicon	Decreases current capacity of H-1 (AZ-63) if >0.1%.
Nickel	Greatly decreases current capacities of all alloys if >0.001%.
Copper	Decreases current capacity if >0.02%.
Others	Not commonly found in amounts that are detrimental.
Lead (Pb)	Decreases current capacity if >0.04%.
Tin (Sn)	Decreases current capacity if >0.005%.

* Data provided by Dow Chemical U.S.A.

The purchaser should request a verifiable spectrographic analysis of any anode purchase to assure that the alloy falls within the predetermined range of acceptable impurities. The anodes should be identified by heat number and date of manufacture. The chemical analysis should detail the heat number, the date of manufacture, a listing of the impurities with the percentages of each, and be signed by a technically qualified person.

Anode current capacity and oxidation potential may be measured using ASTM Standard G97-97 "Standard Test Method for Laboratory Evaluation of Magnesium Sacrificial Anode Test Specimens for Underground Applications".

Zinc Alloys

Zinc anodes are used in low resistance soils where driving potential is not a major factor in

system design. They are available in a variety of sizes and shapes including bracelet anodes for marine pipelines, docks and piers, hull anodes for marine vessels, and in ribbon form for use in utility ducts and for AC mitigation. Zinc is not recommended in environments where carbonates or bicarbonates are found, or where the temperature of the electrolyte is over 120° F. Under these situations zinc becomes cathodic, rather than anodic, to steel and its use should be avoided. Tables 3-4 and 3-5 show some common zinc anode sizes and compositions respectively.

When used strictly as an anode, zinc is well suited for low resistivity environments such as sea water, salt marshes, and brackish water. Zinc normally becomes impractical for protecting large bare areas when the resistivity of the electrolyte exceeds 1,500 ohm-cm.

Zinc anodes are also used as grounding cells for AC mitigation and electrical protection of isolators. Figure 3-3 shows two zinc anodes used in a grounding cell installed across an isolating flange.

Zinc anodes are also used as stationary reference electrodes.

Aluminum Alloys

Aluminum has been generally limited to applications of sea water and chloride rich environments such as offshore petroleum platforms, marine pipelines and onshore oil production separation equipment using a saltwater tank. There are two common alloy families. One uses mercury, the other uses indium, to reduce the passivating effect of the oxide film that forms on aluminum. Compositions are shown in Table 3-6.

The mercury alloys are effective in high chloride environments where chloride levels are consistently greater than 10,000 ppm. Sea water has an average chloride level of 19,000 ppm.

Indium alloys are effective in waters containing

TABLE 3-4**Zinc Dimensions and Weights**

Weight (lbs)	Height	Width	Length	Core (dia.™)
Bare Zinc Anodes				
5	1.4	1.4	9	0.250
12	1.4	1.4	24	0.250
18	1.4	1.4	36	0.250
30	1.4	1.4	60	0.250
30-A	2.0	2.0	30	0.250
45	2.0	2.0	45	0.250
60	2.0	2.0	60	0.250
Zinc Ribbons				
2.4	1.0	1.250	--	0.185
1.2	0.625	0.875	--	0.135
0.6	0.500	0.563	--	0.130
0.25	0.344	0.469	--	0.115

TABLE 3-5**Zinc Alloy Compositions**

Element	ASTM B418-01 Type I (sea water)	ASTM B418-01 Type II (soil)
Aluminum	0.1 - 0.5%	< 0.005%
Cadmium	0.025 - 0.07%	< 0.003%
Iron	< 0.005%	< 0.0014%
Lead	< 0.006%	< 0.003%
Copper	< 0.005%	< 0.002%
Others	—	0.1%
Zinc	Balance	Balance

TABLE 3-6**Aluminum Alloy Composition and Performance**

Element	Mercury Family Al/Hg/Zn	Indium Family Al/In/Zn
Zinc (Zn)	0.35 - 0.60%	2.8 - 6.5%
Silicon (Si)	0.14 - 0.21%	0.08 - 0.2%
Mercury (Hg)	0.035 - 0.060%	---
Indium (In)	---	0.01 - 0.02%
Copper (Cu)	0.004% max	0.006% max
Iron (Fe)	0.10% max	0.12% max
Aluminum (Al)	Balance	Balance
Performance		
Consumption (lb/Ay)	6.8 - 7.0	7.4 - 8.4
Ampere hours/lb	1250 - 1290	1040 - 1180
Potential - Ag/AgCl	1.05	1.10
- Cu/CuSO ₄	1.10	1.15

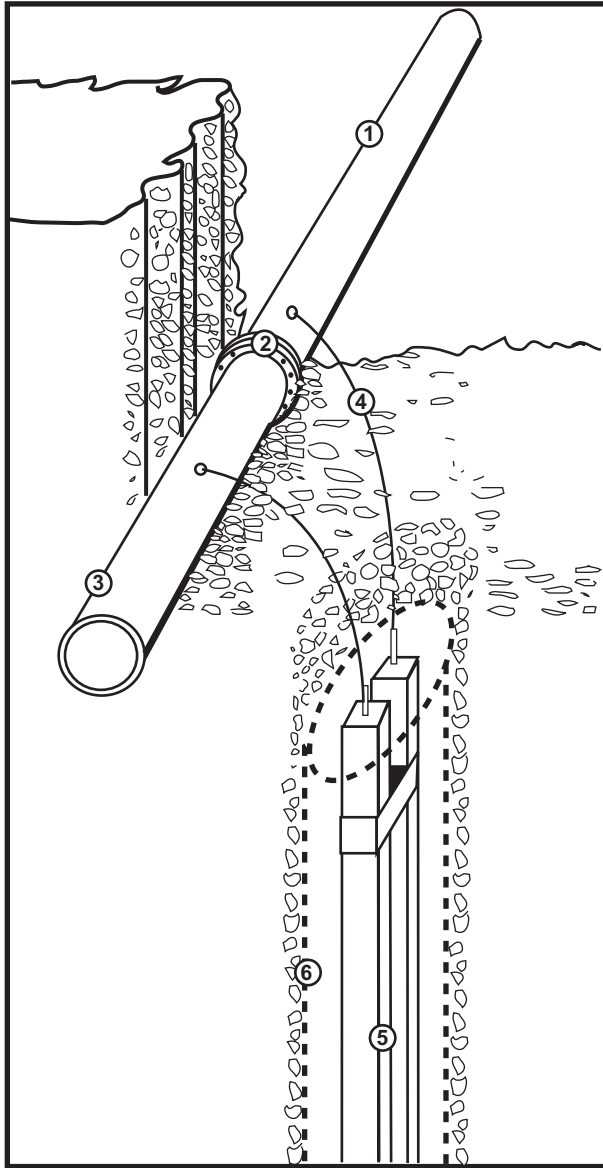

TWO UNIT ZINC GROUNDING CELLS

FIGURE 3-3

1,000 ppm or more of chlorides.

The mercury alloy is used in free flowing sea water and its principle advantage is the high number of ampere hours of capacity. Refer to Table 3-6. Its primary disadvantages are that it cannot be used in brackish water, in silt/mud zones, or at elevated temperatures. Under high humidity atmospheric storage conditions some grades have been known to degrade and become totally unusable prior to installation. There is some controversy also concerning the long term environmental effects of this alloy in sea water.

The indium alloy is used in free flowing sea water, brackish water, silt/mud zones, and at elevated temperatures. Its basic limitation is a reduction in ampere hours of capacity.

Aluminum anodes have a variety of standard cores such as pipe, strap, bar, end type, side type, etc. The type of core must be specified. Cores should never be galvanized prior to pouring the anode.

On major projects it is advisable to monitor the quality control process and inspect the finished materials prior to shipment.

Just as with the magnesium, it is important that a certified analysis accompany each anode heat.

The purchaser should request a verifiable spectrographic analysis of any anode purchase to assure that the alloy falls within the predetermined range of acceptable impurities. The anodes should be identified by heat number and date of manufacture. The chemical analysis should detail the heat number, the date of manufacture, a listing of the impurities with the percentages of each, and be signed by a technically qualified person. Some manufacturers identify each anode with a stamp or tag, others may label each pallet of bare anodes with an identity number painted on the side.

IMPRESSED CURRENT CATHODIC PROTECTION SYSTEMS

Unlike galvanic systems, impressed current systems utilize an external power source such as a rectifier, electrically connected to less soluble anodes. The anodes are connected to the positive terminal of the rectifier and the circuit is completed by attaching the negative terminal to the structure to be protected. Refer to Figure 3-4 for the components in an impressed current system.

An impressed current system is used to protect large bare and coated structures and structures in high resistivity electrolytes. Care must be taken when employing this type of system so that cathodic coating damage and the potential for the development of stray currents adversely affecting other foreign structures, are minimized.

Prior to the 1970's there were only three types of anodes primarily used for impressed current anode beds: high silicon cast iron, graphite and scrap steel. As technology progressed, so did the materials used for impressed current anodes. When installation and operating costs are assessed, very few anodes can be used universally for any type of application and still achieve a desirable design life.

In most soils, anodes evolve oxygen and the anode oxidizes as the current is discharged. In chloride containing soils or water, anodes evolve chlorine gas which forms hydrochloric acid, and the anodes can breakdown chemically. Some anodes perform well in the presence of oxygen and others in the presence of acids.

Specifications

It goes without saying that if corrosion personnel do not effectively detail the type of anode construction they expect, they will probably get less than they expected. The following are minimum details to address in an anode specification.

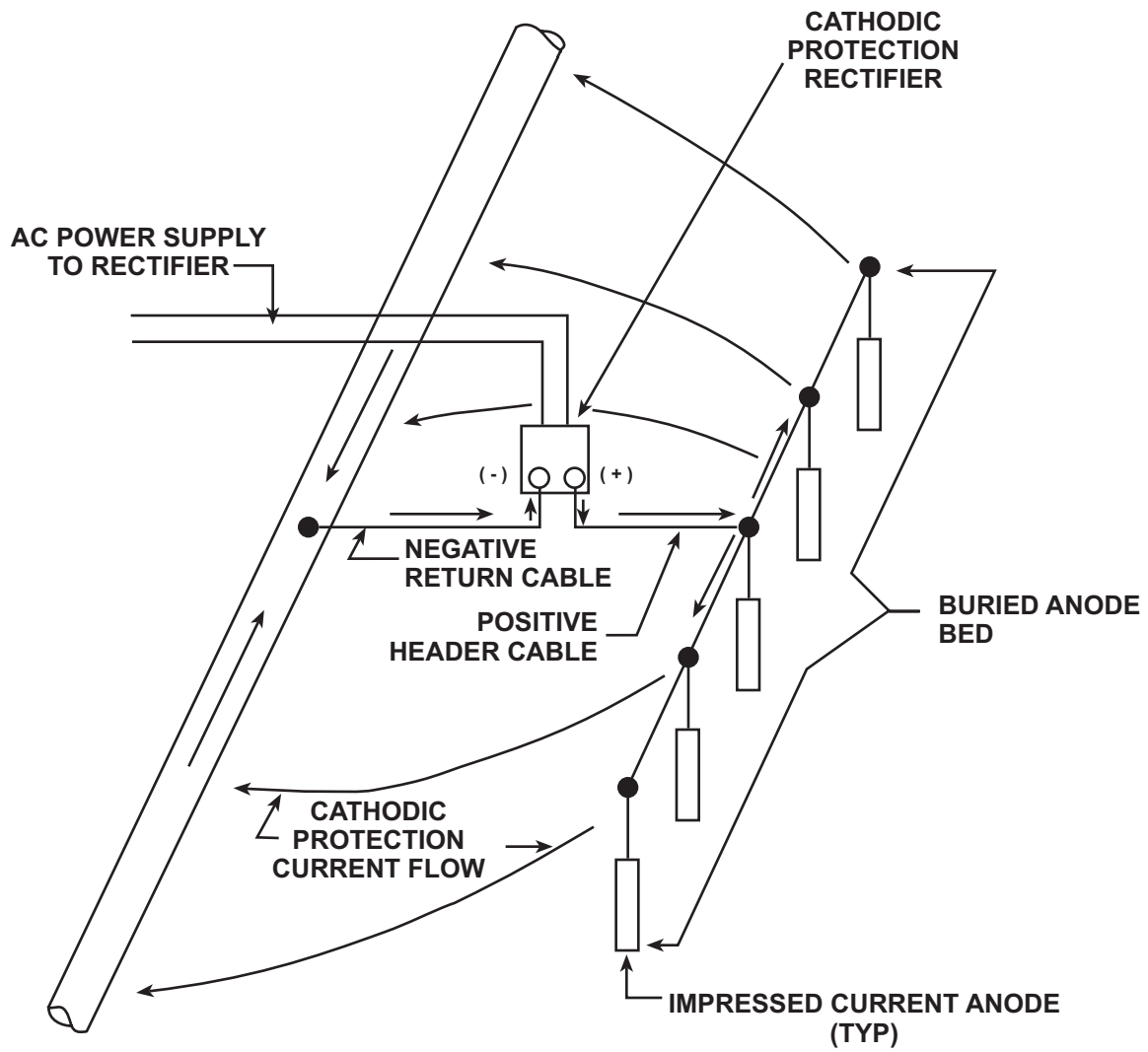

TYPICAL IMPRESSED CURRENT CATHODIC PROTECTION SYSTEM

FIGURE 3-4

1. Anode Size - composition, dimensions and weight, within 2%.
2. Cable - size, type, insulation/thickness, length.
3. Type of Connection - end, center, <0.02 ohms resistance.
4. Termination - epoxy cap, full encapsulation, shrink cap.
5. Packaging - bare, canister size/gauge, backfill type, weight.
6. Palletizing - size, padding, number per pallet.
7. Options - lifting rings, centering devices.

The sections of the specification covering the various types of impressed current anodes should include additional information on construction methods.

High Silicon Cast Iron

The typical alloy for cast iron anodes is ASTM A518 Grade 3. Table 3-7 shows the metallurgical composition of this alloy.

The principal reason for the good performance of cast iron anodes is the formation of a silicon oxide (SiO_2) film on the anode surface, reducing the rate of oxidation, and retarding the consumption rate. Chromium is added to produce a chlorine resistant alloy and improve its life in chloride containing soils and water.

Cast iron anodes have good electrical properties and the resistivity of the alloy is 72 micro ohm-cm at 20° C. In soils, the anodes are usually backfilled with metallurgical or calcined petroleum coke breeze to increase the effective anode surface area and provide uniform consumption. By increasing the diameter or length of a cylindrical anode, the anode to electrolyte resistance is lowered. Increasing the length has a greater effect than increasing the diameter.

The high tensile strength of the anode is an asset in some circumstances, but it is brittle and subject to fracture from severe mechanical and thermal shock.

Cast iron anodes are manufactured in a wide variety of dimensions, shapes and weights. Refer to Table 3-8 for a description of the various sizes.

Solid cast iron anodes have the lead wires attached at the end as shown in Figure 3-5. The connection is encapsulated with epoxy or a heat shrinkable cap to protect it from electrical discharge.

Current typically discharges from conventional end connected anodes at a greater rate (3:1) from the area of the cable connection than from the body of the anode. This causes an exaggerated attack, called "end effect". A connection in the center of a tubular anode, suitably sealed at each end, has been demonstrated to be effective against this rapid loss of the anode at the cable connection. See Figure 3-6.

Testing of chromium bearing tubular anodes in artificial sea water has shown the consumption rate to be about 0.7 pounds per ampere year at a discharge rate of 3.5 amps per square foot of anode surface area. No data has been provided for soil or mud conditions but consumption in these environments could double or triple the consumption rate.

Tubular anodes range in size from 2.187" to 4.750" in diameter, and from 46 pounds to 175 pounds in weight, with surface area ranging from 50 percent - 170 percent greater than conventional rod type anodes. The anode cable connection strength should be tested to be equal to the breaking strength of the cable without any change in the 0.004 ohms or less connection resistance.

Thus, for the following cable sizes, connection pull test values should be:

TABLE 3-7**Cast Iron Composition
ASTM A518 Grade 3**

ELEMENT	COMPOSITION
Silicon	14.2 - 14.75%
Carbon	0.70 - 1.10%
Manganese	1.50% max
Molybdenum	0.20%
Chromium	3.25 - 5.00%
Copper	0.50% max
Iron	Balance

TABLE 3-8**Typical Cast Iron Rod Anode Dimensions**

NOMINAL WEIGHT lbs (kgs)	NOMINAL DIAMETER in (mm)	NOMINAL LENGTH in (mm)	NOMINAL AREA ft² (m²)
1.0 (.5)	1.1 (28)	9 (230)	.22 (.02)
5.0 (2.3)	2.0 (51)	9 (230)	.39 (.04)
9.0 (4.1)	2.5 (64)	9 (230)	.50 (.05)
26 (12)	1.5 (38)	60 (1520)	2.0 (.19)
43 (20)	2.0 (51)	60 (1520)	2.6 (.24)
44 (20)	2.0 (51)	60 (1520)	2.6 (.24)
60 (27)	2.0 (51)	60 (1520)	2.7 (.25)
110 (50)	4.0 (102)	60 (1520)	4.0 (.37)
220 (100)	4.5 (114)	60 (1520)	5.5 (.51)

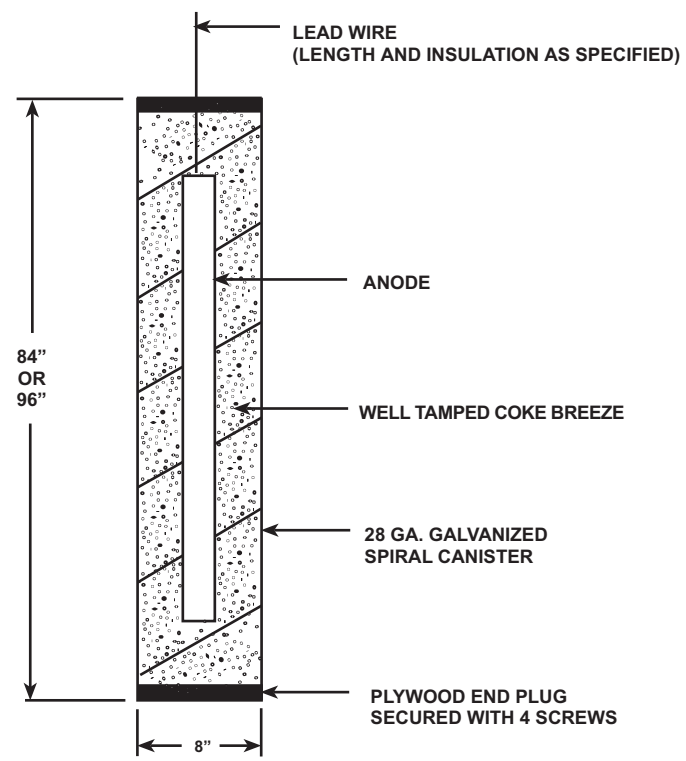
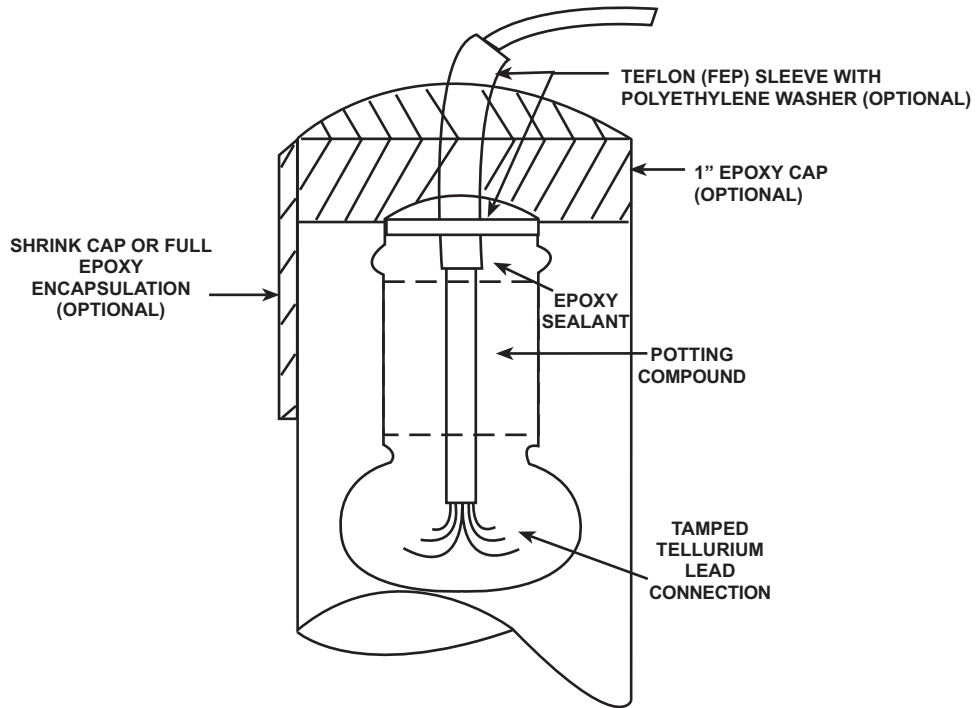

TYPICAL CAST IRON ANODE LEAD WIRE CONNECTION AND PACKAGING

FIGURE 3-5

NOMINAL WEIGHT lbs (kgs)	NOMINAL DIAMETER in (mm)	NOMINAL LENGTH in (mm)	NOMINAL AREA ft ² (m ²)
31 (14)	2.6 (66)	41 (1067)	2.4 (.22)
50 (23)	2.6 (66)	60 (1520)	3.5 (.33)
46-50 (21-23)	2.2 (56)	84 (2130)	4.2 (.39)
63-70 (29-32)	2.6 (66)	84 (2130)	4.9 (.46)
85-95 (39-43)	3.8 (97)	84 (2130)	7.0 (.65)
110-122 (50-55)	4.8 (122)	84 (2130)	8.8 (.82)
175-177 (79-80)	4.8 (122)	84 (2130)	8.8 (.82)
230 (104)	4.8 (122)	84 (2130)	8.8 (.82)
260 (118)	6.7 (170)	76 (1981)	11.4 (1.06)
270 (122)	6.7 (170)	84 (2130)	12.3 (1.14)

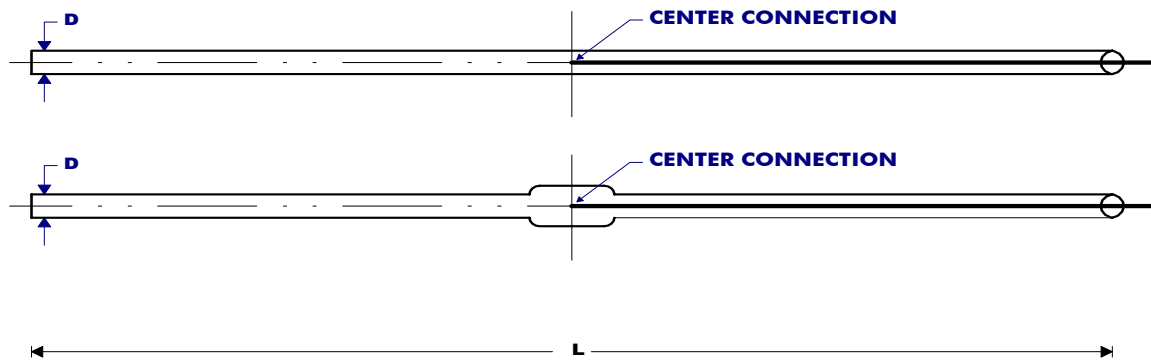

TYPICAL TUBULAR ANODE DIMENSIONS

FIGURE 3-6

Connection Strength	Cable Break Strength
No. 8 - 799 pounds	525 pounds
No. 6 - 1258 pounds	832 pounds
No. 4 - 1980 pounds	1320 pounds

Graphite Anodes

Graphite rods have been used as an impressed current material for many years. The basic configurations consist of round or square rods, manufactured from a slurry of powdered petroleum, coke and coal tar resin. The coal tar is used as a bonding agent to hold the graphite particles together and then baked at high temperatures to fuse the mixture. This process increases the resistance to oxidation and subsequent breakdown.

There are many types of graphite compositions and the type used for cathodic protection anode beds is one of the most porous. Graphite cathodic protection anodes should have a specific gravity of 1-6 grams/cc minimum. The porosity allows moisture penetration to migrate to the connection, causing failure at the cable connection. The porosity is reduced by impregnating the rods with filler of linseed oil, micro-crystalline wax, or phenolic based resin.

There is controversy concerning the best type of filler and even whether a filler really reduces moisture penetration over long periods of time. Whatever filler is used, it should be applied by a method that assures complete penetration of the cross-section of the graphite anode. In soils, graphite anodes must be backfilled with metallurgical or calcined petroleum coke breeze to increase the effective anode surface area and provide a uniform low consumption rate.

Anode to lead connection is just as critical as with cast iron. See Figure 3-7. Both end and center connections are available. Additional specification details should include:

1. Type of connector - lead, brass, molten, compression.

2. Connection depth/diameter - 3", 4", 5", centered.
3. Connection sealant - thermoplastic, thermosetting (epoxy).
4. Cable sealant - TFE tubing, shrink cap, encapsulation.
5. Impregnation - wax, linseed oil, resin.
6. Sizes - 3" x 30" - 2 sq. ft., 3" x 60" - 4 sq. ft., 4" x 40" - 3.5 sq. ft., 4" x 80" - 7 sq. ft.

Graphite should not be operated at current densities exceeding one ampere per square foot in soil with coke breeze backfill. For optimum life in soils, most engineers design graphite anodes for a maximum density of 0.20 amperes per square foot, or one ampere per 3" x 60" rod. If current densities are within these ranges, the consumption rate will be approximately 2 pounds per ampere year (Ay). Exceeding these limits causes the material to become mushy and less conductive, due to chemical breakdown of the crystal boundary.

As with cast iron, graphite is brittle and may be easily damaged during transportation, either bare or packaged. Special handling and padding is necessary to prevent cracking and breaking.

Aluminum Anodes

Occasionally aluminum is used as an impressed current anode for protecting the interior of water tanks, particularly where ice destroys the anodes annually. The consumption rate of 9 pounds per ampere year may limit the cost effectiveness on the basis of cost per year of service compared to other anode systems. There are also several proprietary systems using other anode materials that will withstand icing.

Lead Silver Anodes

Lead alloy anodes are only used in free flowing sea water applications and may employ various metals such as antimony lead, tin, and 1 or 2% silver. Commonly supplied in rod or strip form of

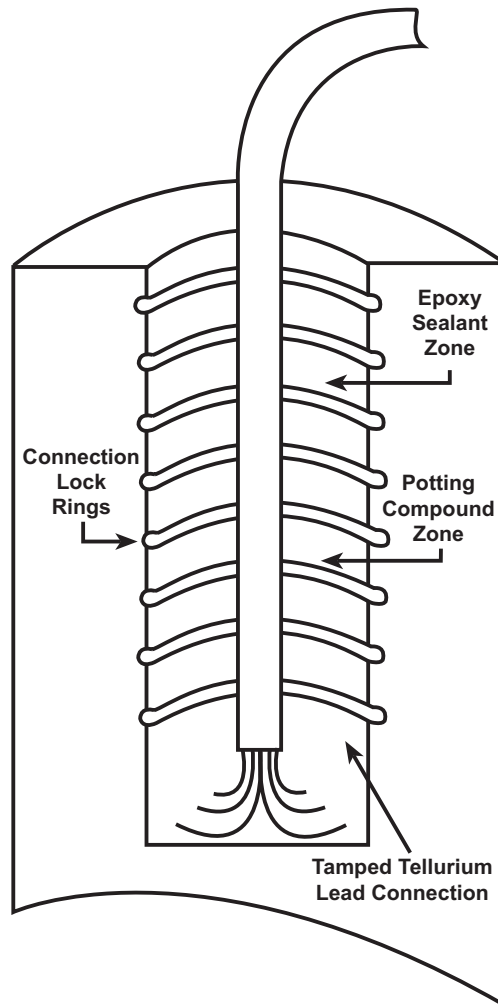

**TYPICAL GRAPHITE ANODE
LEAD WIRE CONNECTION**

FIGURE 3-7

1.5" diameter by 10" long, they have been used extensively in Europe with a 2% silver alloy, which doubles its life.

Upon initial start up, the consumption rate is about three pounds per ampere year and eventually a black, passive film of lead peroxide forms to extend the life of the anode, resulting in consumption of about 0.2 pounds per ampere year. Normal current density ranges from 3 to 25 amps per square foot. In silting or low chloride conditions, this oxide film does not form and the anode is consumed rapidly.

Cable connections are made by drilling a hole and silver soldering the lead wire at the base of the hole. The connection cavity is then filled with epoxy to prevent moisture penetration.

Installation is accomplished by hanging the anodes from a structure, dock or pier in a perforated fiberglass pipe or by a support device to maintain its position. This support is important to prevent ice damage and keep the anodes from coming in contact with mud or silt.

Magnetite Anodes

Magnetite (Fe_3O_4), a European inspired anode, is itself an iron based corrosion product. Therefore, there is little or no corrosion involved during current discharge, but the relatively small surface area is better suited to brackish or sea water applications than soil.

The anodes are manufactured and shipped direct from the factory with the lead wire attached and distributors splice extra wire to meet user requirements. The material is brittle and a factory installed lead wire attachment to the internal wall of the anode is critical. Figure 3-8 shows the anode construction.

Some applications have involved offshore platforms, power plants, and limited underground use. As of this writing, there is limited background information on the use and success of this anode.

Mixed Metal Oxide Anodes

Mixed metal oxide anodes were developed in Europe during the early 1960's for use in the industrial production of chlorine and caustic soda. The first known use of the technology for cathodic protection use occurred in Italy to protect a sea water jetty in 1971. These anodes exhibit favorable design life characteristics while providing current at very high density levels. The oxide film is not susceptible to rapid deterioration due to anode acid generation, rippled direct current, or half wave rectification, as is common with other precious metal anodes.

The composition of the anode consists of a titanium rod, wire, tube or expanded mesh (refer to Figure 3-9) with the oxide film baked on the base metal. Sometimes these anodes are referred to as dimensionally stable, ceramic or linear distributed anodes.

For oxygen evolution environments such as soils, the anode oxide consists of ruthenium crystals and titanium halide salts in an aqueous solution that is applied like a paint on the base metal and baked at 400 to 800° C forming a rutile metal oxide. After baking, the rutile develops a matte black appearance and is highly resistant to abrasion.

For chlorine evolving environments such as sea water, the oxide consists of an aqueous solution of iridium and platinum powder that is also baked at high temperatures to achieve a desirable film.

Some manufacturers produce variations of the oxide films specifically for chloride or non-chloride electrolytes and they are not interchangeable.

Normally, titanium will experience physical breakdown around 10 volts, but the oxide film is so highly conductive (0.00001 ohm-cm resistivity) that the current is discharged from the oxide rather than the base metal even with a rectifier voltage of 90 volts in soils. This is in contrast to the insulating titanium dioxide film

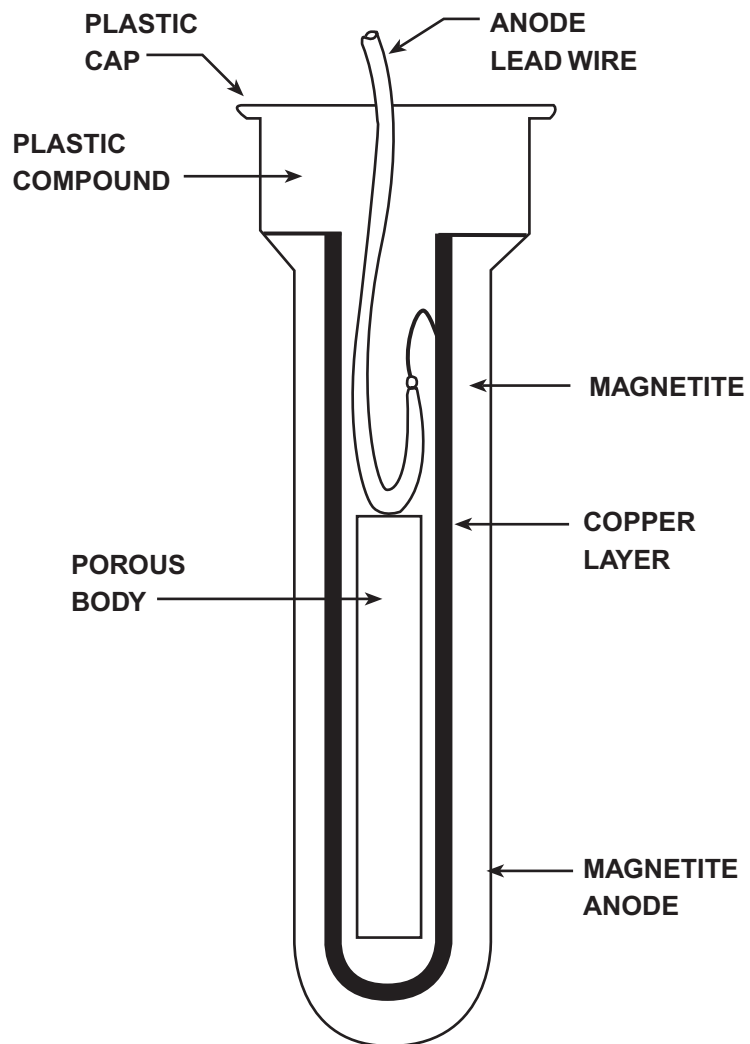

TYPICAL MAGNETITE ANODE

FIGURE 3-8

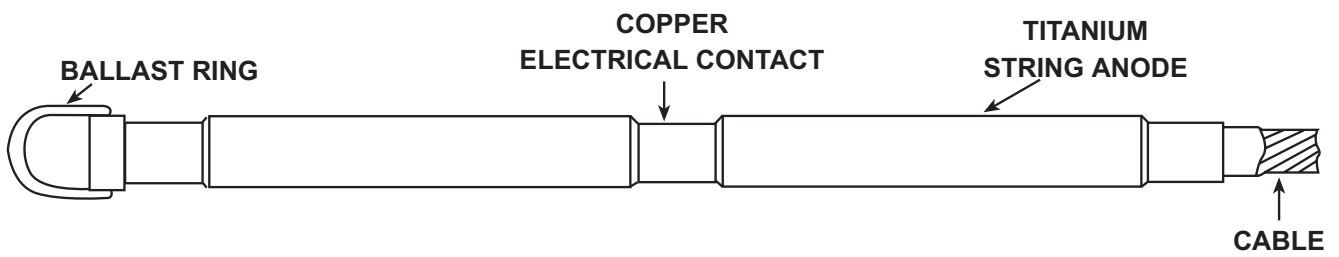
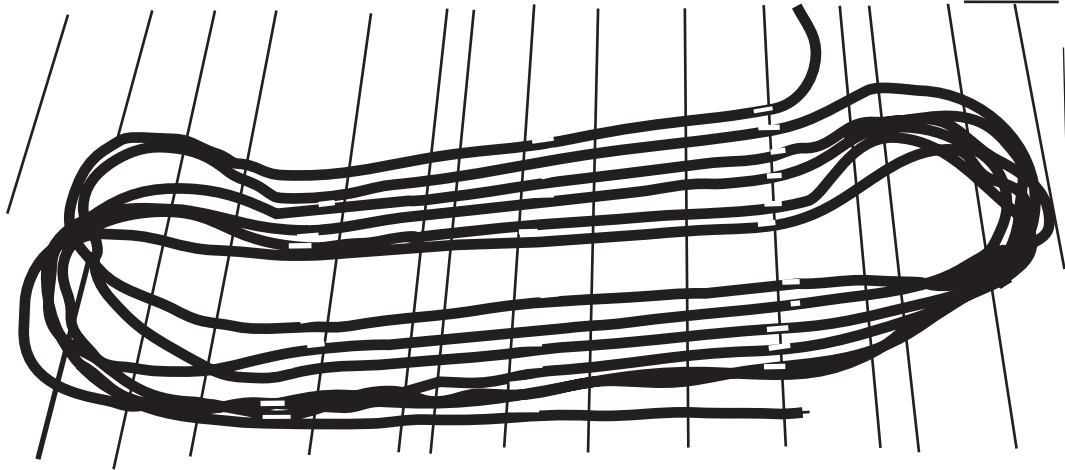

MIXED METAL ANODE

FIGURE 3-9

that naturally forms on the surface of bare titanium. When the mixed metal oxide film has been consumed, the insulating titanium dioxide film will cover the anode and not allow current to discharge unless the applied voltage is greater than 10 volts in sea water or 50 to 70 volts in fresh water.

The maximum recommended current densities for various electrolytes are:

Soil, Mud, Fresh Water	9.0 amps/ft ² (20 years)
Sea water	55.7 amps/ft ² (15 years)

Anodes in soil or mud must be backfilled with fine, low resistance, calcined petroleum coke breeze for maximum life and performance. Even when the anode is pre-packaged with petroleum coke, conservative engineering judgment would dictate that the anode package be surrounded with metallurgical coke, prior to finishing the backfilling with native soil. Consumption rates at these densities range from 0.5 mg/Ay in sea water to 5 mg/Ay in coke breeze, fresh water and sea mud.

As with any anode, the connection must be constructed so as to be moisture proof, water tight and have no more than 0.001 ohm resistance.

Advantages of mixed metal oxide anodes:

- Lightweight and Unbreakable
- Dimensionally Stable
- Negligible Consumption Rate
- High Current Density Output
- Inert to Acid Generation
- Cost Effective

Mixed metal oxide anodes are available in a variety of shapes including wire, rods, tubes and mesh.

Platinum Anodes

Platinum can be used as an anode coating for many types of cathodic protection installations.

Structures in a vast array of environments such as underground, offshore, concrete, power plants, and the internal surfaces of piping, tanks and machinery have utilized platinum for cathodic protection systems. In sea water, platinum has a low consumption rate, 0.00018 pounds per ampere year, so only a small amount is needed for a twenty-year anode life. In soil and fresh water, the consumption may range up to 0.005 pounds per ampere year depending on the resistivity of the electrolyte and the amount of coke breeze surrounding the anode in soil applications. Pure platinum, by itself, would be too expensive. Therefore, it is normally coated over noble base metals such as titanium and niobium. When anodes are in the form of wire and rods, there may be a copper core to increase the conductivity for lengths in excess of 25 feet since titanium and niobium are relatively poor electrical conductors compared to copper. Wire anodes for use in deep anode beds, and packaged anodes for surface anode beds are manufactured. Figure 3-10 shows different types and sizes of platinum anodes.

The passive film on titanium starts to break down at 10 volts, anode to cathode potential, therefore, these anodes are limited to low resistance environments such as sea water. Niobium has a break down voltage of 120 volts, anode to cathode potential, and is used in higher resistivity electrolytes.

Current densities range from 50 amps per square foot in soils to 500 amps per square foot in sea water, with a platinum thickness of 300 micro inches, depending on the anode surface area and the method of coating application. Platinum has been coated on base metals using many techniques including sputtered electrode position, cladding, and metallurgically bonded.

In metallurgically bonded anodes, the metals are compressed together in an oxygen free vacuum. This provides an oxide free, low resistance bond between the metals.

Cladding involves wrapping a thin sheet of

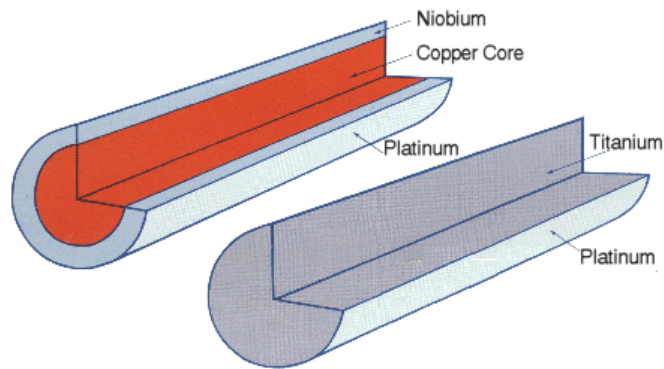

20% Niobium

Diameter Inches	Nb Thickness Inches	Resistance microhm/ft	Pt Thickness μ -in (2X)*
.750	.038	22	300 (600)
.500	.025	50	200 (400)
.375	.019	89	150 (300)
.250	.013	201	100 (200)
.188	.009	356	75 (150)
.125	.006	806	50 (100)

40% Niobium

Diameter Inches	Nb Thickness Inches	Resistance microhm/ft	Pt Thickness μ -in (2X)*
.375	.038	113	150 (300)
.250	.025	256	100 (200)
.188	.019	453	75 (150)
.125	.013	1025	50 (100)
.093	.010	1822	38 (75)
.063	.007	4102	25 (50)
.031	.0035	16,408	12.5 (25)

100% Titanium

Diameter Inches	Ti Thickness Inches	Resistance microhm/ft	Pt Thickness μ -in
.750	Solid	468	300
.500	Solid	1054	200
.375	Solid	1874	150
.250	Solid	4215	100
.188	Solid	7454	75
.125	Solid	16,862	50

* Double Platinum Thickness

PLATINUM ANODES

FIGURE 3-10

platinum around a rod and spot welding the platinum to the base metal at the overlap area.

Electrodeposition techniques plate a film of platinum on the base metal.

Thermal decomposition and welded techniques exhibit the same problems as cladding, and as of the late 1980's are rarely used.

Each process has its advantages and disadvantages and the corrosion worker should evaluate them for each application.

The anode to cable connection is critical and improper connections will result in very early premature failure. Users should assure that the anodes are manufactured in compliance with their specifications by skilled personnel under the guidance of established quality control methods.

The major disadvantage to platinum is poor resistance to anode acid evolution in static electrolytes, rippled direct current, and half wave rectifiers. Use of a 3-phase transformer rectifier in sea water systems has been known to double the life of platinum anodes by reducing the ripple in the DC output.

Very rapid deterioration will occur if the anode is driven at current discharges exceeding the manufacturer's limitations. In underground applications, platinum anodes have had only limited success as of this writing.

Polymer Conductive Anodes

In 1982, a new anode material was test marketed to provide a small amount of current in restricted spaces such as internal pipe surfaces, heat exchangers, utility ducts, and areas shielded from conventional anode bed current.

The material resembles electrical cable but actually consists of a stranded copper conductor with an extruded, conductive polyethylene (see Figure 3-11). This concept is used in underground concentric power cables

as a conductive shield around the ground wires. The polymer contains carbon granules which discharge the current. The anode should be backfilled in carbonaceous coke breeze for maximum life.

An optional plastic mesh is available, to separate the anode from the cathode in restricted spaces, preventing electrical shorting between the anode and cathode. Currently the material is available in four different diameters and the current output ranges from 3 to 9 milliamperes per linear foot.

Scrap Steel Anodes

For operating companies who have access to scrap pipe or old rails, this type of anode may be economical if properly installed. If pipe is used, multiple lead wire connections are made at close intervals and carefully coated at each location to prevent premature connection failure. The major cost of the system is in labor, welders and heavy construction equipment necessary to install the components. If an existing abandoned line is used, the costs may be less, depending on depth and number of lead wire connections required.

A major disadvantage in the use of scrap steel anodes is the high consumption rate of 20 lb/A-yr.

Backfill for Impressed Current Anodes

Special carbonaceous backfill is used to surround most impressed current anodes in soil to reduce the anode bed resistance and extend the anode life. The only exception applies to anodes used in photovoltaic power supply systems, where magnesium anode backfill is used due to the high back EMF voltage encountered with carbonaceous backfill.

Coke breeze is conductive and transfers current from the anode to the interface of native soil. Some types pass the current more efficiently by more electronic conductance and others are less efficient and current passes electrolytically.

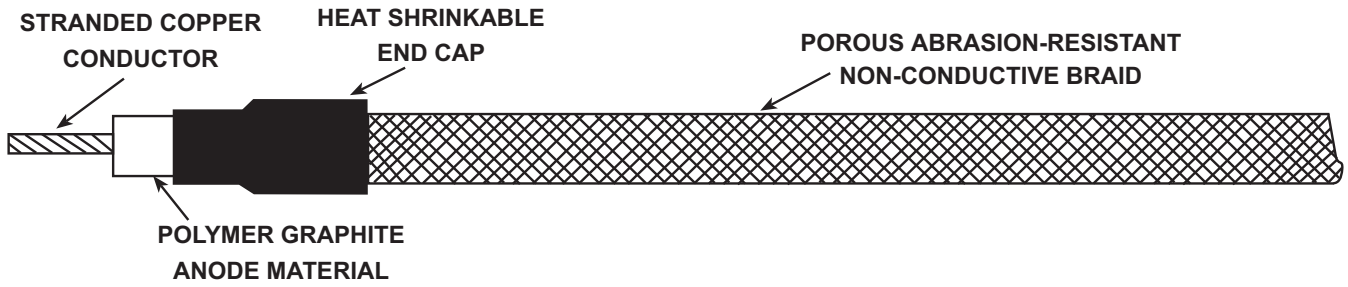

POLYMER ANODE

FIGURE 3-11

The first type is metallurgical coke breeze, derived as a waste by-product of coking (heating) coal, associated with steel production. The composition and particle size of coke may greatly enhance the life of an anode and should be considered at the design stage. Most often the particle size is about 0.375" ($\frac{3}{8}$ ") and smaller for surface anode bed backfill. The smaller the particle size, the greater the compaction and conductivity. Metallurgical coke should not exceed 50 ohm-cm when measured using ASTM G-58 Soil Box Test Method, temperature corrected. The carbon, iron, copper, sulfur content and weight per cubic foot are important values to analyze prior to installation. Refer to Table 3-9. Metallurgical coke breeze is available bagged or bulk and is often used in prepackaged impressed current anodes.

Calcined petroleum coke consists of finely screened particles of coke that are typically derived as a waste by-product of crude oil refining. It consists predominately of round carbon granules and is much more conductive than metallurgical grades of coke. The resistance should be less than 2 ohm-cm using ASTM G-58 Soil Box Test Method, temperature corrected. Since resistance values are low, high current density is less prone to gas generation and the incidence of gas blocking in deep anode beds using a 92 percent carbon content coke is rare. Some grades incorporate a surfactant, similar to detergent, to reduce water tension and promote pumping and compaction in deep anode beds.

WIRE AND CABLE

Conductors typically used for underground service are made of solid or stranded copper, rated at 600 volts, with a variety of insulation materials designed for the type of electrical and chemical exposure to be encountered (see Table 3-10).

Conductors are rated on their ampacity under certain temperature and service conditions (see Table 3-11). Insulation values also vary depending on wet or dry conditions. The

following data are general in nature, covering the most common types, and specification data should be obtained directly from manufacturers pertaining to their product.

CABLE CONNECTIONS AND SPLICES

Most connections to structures are made with an exothermic welding process which thermally bonds the conductor to the structure. Other methods may change the temper of the conductors causing them to become brittle and damage the insulating properties of the cable insulation.

Exothermic welding uses a graphite mold to contain the mixture of copper alloy and magnesium starter powder. After igniting the powder with a flint gun, the powder becomes molten and drops on the cable and structure. The slag on the connection is removed by lightly striking the weld with a chipping hammer after cooling. Figure 3-12 shows a typical set-up for an exothermic weld.

Structures that contain certain types of flammable substances may require the use of grounding clamps to make the cable attachment.

Special attention should be given to coating any attachment or cable splice to prevent bi-metallic corrosion attack. The coating should be solvent free to prevent deterioration of the insulation.

Splicing cables together may involve exothermic welding, high compression crimpits, or split bolts as shown in Figure 3-13. Split bolts may loosen with age and are generally used for magnesium anode header cable splices only.

SPLICE ENCAPSULATION

There are many methods available for moisture proofing cable splices:

1. Hand wrapping
2. Epoxy mold encapsulation
3. Shrink tubing and sleeves

TABLE 3-9**Coke Breeze Composition**

Type	Bulk Density (lb/cu ft)	Porosity (%)	Carbon (lb/cu ft)
Metallurgical	45	48.0	32.51
Petroleum, calcined			
Delayed	48	59.5	47.76
Fluid	54	56.7	49.93
	70	44.0	64.73
	74	40.8	68.53

TABLE 3-10**Wire And Cable Insulation Designations**

Designation	Insulation	Thick (in)	Cable Size	Specification
HMWPE	High Molecular Weight Polyethylene	.110 .125	No 8 - No 2 No 1 - 4/0	D-1248, Type 1 Class C, Cat. 5
TW	Polyvinyl Chloride (PVC)	.030 .034 .060	No 14 - No 10 No 8 No 6-No 2	U.L. Standard 83 (60° C wet/dry)
THW	Polyvinyl Chloride (PVC)	.045 .060	No 14 - No 10 No 8 - No 2	U.L. Standard 83 (75° C wet/dry)
THHN	PVC/Nylon Jacket (.0004" Nylon)	.015 .020	No 14 - No 12 No 10	U.L. Standard 83 (90° C dry)
THWN	PVC/Nylon Jacket (.004" Nylon)	.015 .020	No 14 - No 12 No 10	U.L. Standard 83 (75° C wet)
PVF/HMWPE	Polyvinylidene (.020") HMWPE jacket (.065")	.085	No 8 - No 2	Kynar™ ASTM D-257
ECTFE/HMWPE	Ethylene Chlorotriflora-ethylene (.020") HMWPE jacket (.065")	.085	No 8 - No 2	Haylor™

TABLE 3-11**Conductor Ampacities And Resistances
NACE Corrosion Engineer's Reference Book**

Size AWG	Ampacity* (Copper)	Resistance (Ohms/1000 ft @ 25° C)
No. 16	6	4.18
No. 14	15	2.62
No. 12	20	1.65
No. 10	30	1.04
No. 8	50	0.652
No. 6	65	0.411
No. 4	85	0.258
No.2	115	0.162
No. 1	130	0.129
No. 1/0	150	0.102
No. 2/0	175	0.0811
No. 3/0	200	0.0642
No. 4/0	230	0.0509
250 MCM	255	0.0423
300 MCM	285	0.0353
350 MCM	310	0.0302
400 MCM	335	0.0264
500 MCM	380	0.0212

* Ampacity based on THW and HMWPE insulation

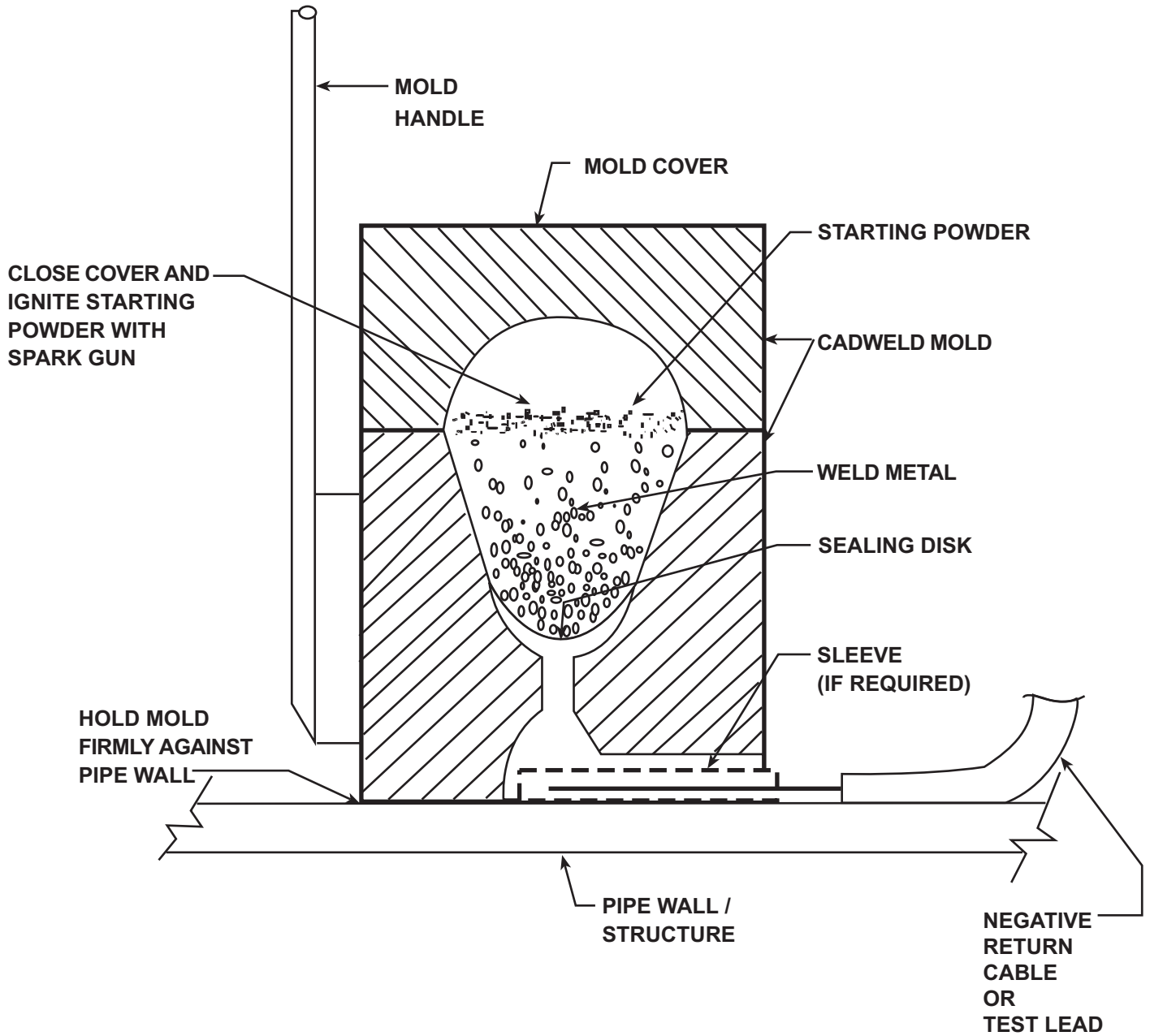

TYPICAL EXOTHERMIC WELD PROCESS

FIGURE 3-12

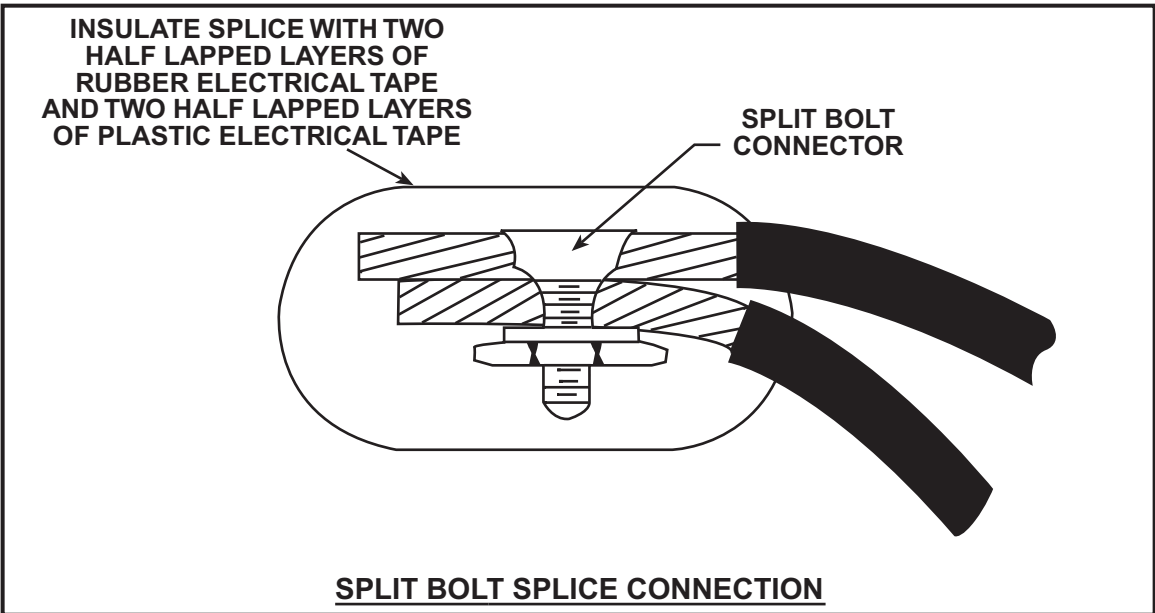
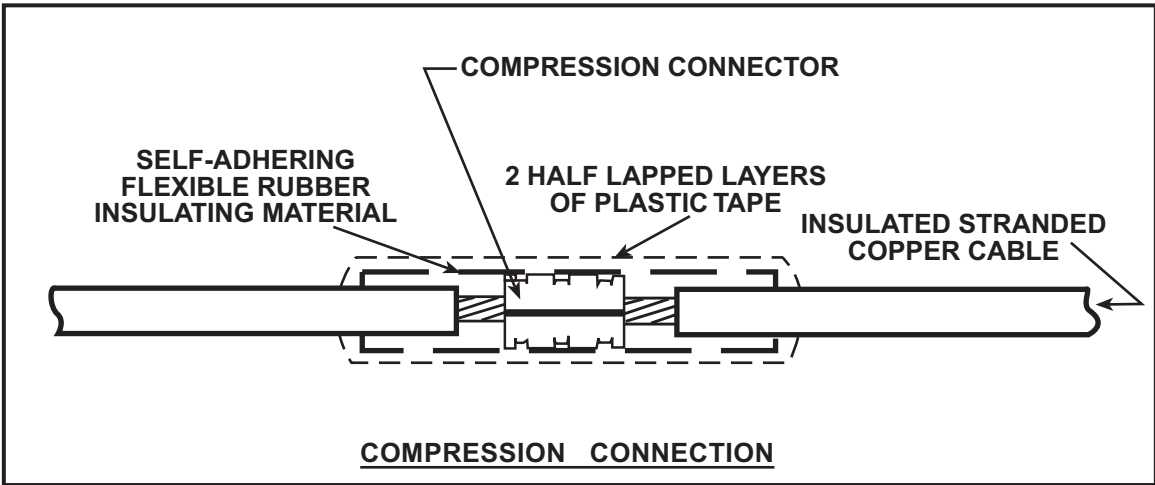
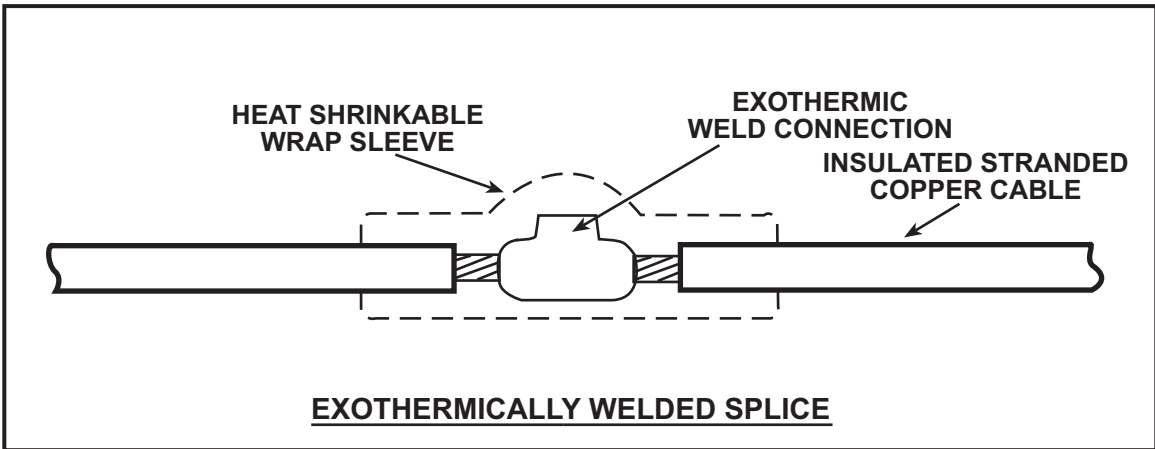

CABLE SPLICE CONNECTIONS

FIGURE 3-13

4. Elastomer/urethane impregnated wrap

Hand wrapping has historically been the most reliable method if done properly, although it is also the most expensive since more labor time is required. The exposed splice area is cleaned with a clean rag, dampened with solvent to remove release oil and human oil on the strands. The area is wrapped with 3 laps of electrical rubber insulating tape extending 2 inches on adjacent insulation, paying special attention to the crease area if wrapping a "Y" connection, as in an anode header cable splice. The entire area is then wrapped with 3 laps of PVC electrical tape and coated with an electrical sealant to complete the splice.

Epoxy molds (Figure 3-14) have been used extensively over the years with some mixed results. Epoxy does not bond to the release oils used on wire, permitting moisture to travel eventually into the connection. Since there is no chemical bond to polyethylene, the mold must extend far enough over the adjacent insulation to prevent hygroscopic moisture migration.

Epoxy molds should not be disturbed or backfilled for 30 minutes at 70° F so that the mixture begins to cross link and bonds to the surfaces. Any movement will distort the material and reduce the adhesion. During cold weather, this time will be extended to approximately 3 hours at 32° F.

Heat shrinkage tubing of irradiated polyethylene with an effective electrical sealant is used to insulate in-line cable splices. This method has proven to be very effective and inexpensive. Care must be taken when using a propane torch so as not to melt or distort the cable insulation while shrinking the sleeve.

Elastomer sealant kits are a recent development that involves wrapping a pliable strip of sealant around the splice area to moisture-proof the connection. An outer wrap of elastic fabric impregnated with a quick setting, moisture cured urethane is wrapped around the sealant and sprayed with water to harden the fabric. This forms a hard shell to eliminate cold

flow of the sealant and prevent rocks or soil stress from damaging the encapsulation.

POWER SUPPLIES

Many sources of direct current (DC) power are available, as discussed in detail in Chapter 7 of the Intermediate Course, for use with impressed current systems as follows:

1. Transformer-Rectifier
2. Solar Photovoltaic Cells
3. Thermoelectric Generators
4. Turbine Generator Units
5. Engine Generator Units
6. Wind Powered Generators

Transformer-rectifiers are the most frequently used power source for impressed current anode systems. The unit consists of a step down transformer to reduce alternating current to an acceptable level, and a rectifying element to convert the alternating current (AC) to direct current (DC). Output terminals and a host of options and accessories complete the final assembly of the unit. See Figure 3-15.

Specifying the various options is easily accomplished using the following options menu. Selecting them properly requires knowledge.

	Options
1. Enclosure Type	Utility Swing Out Cabinets Slide Out Racks Custom Small Arms Proof Pole Mount Wall Mount Pad Mount Photovoltaic (solar panel)
2. Cooling Type	Air Cooled Oil Cooled Explosion Proof Submersible

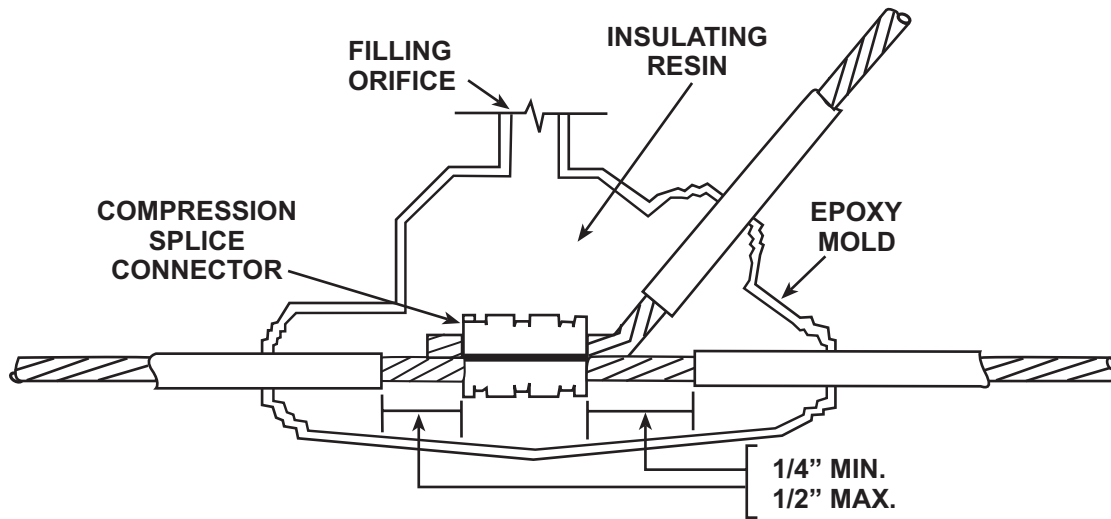

EPOXY ENCAPSULATED SPLICE

FIGURE 3-14

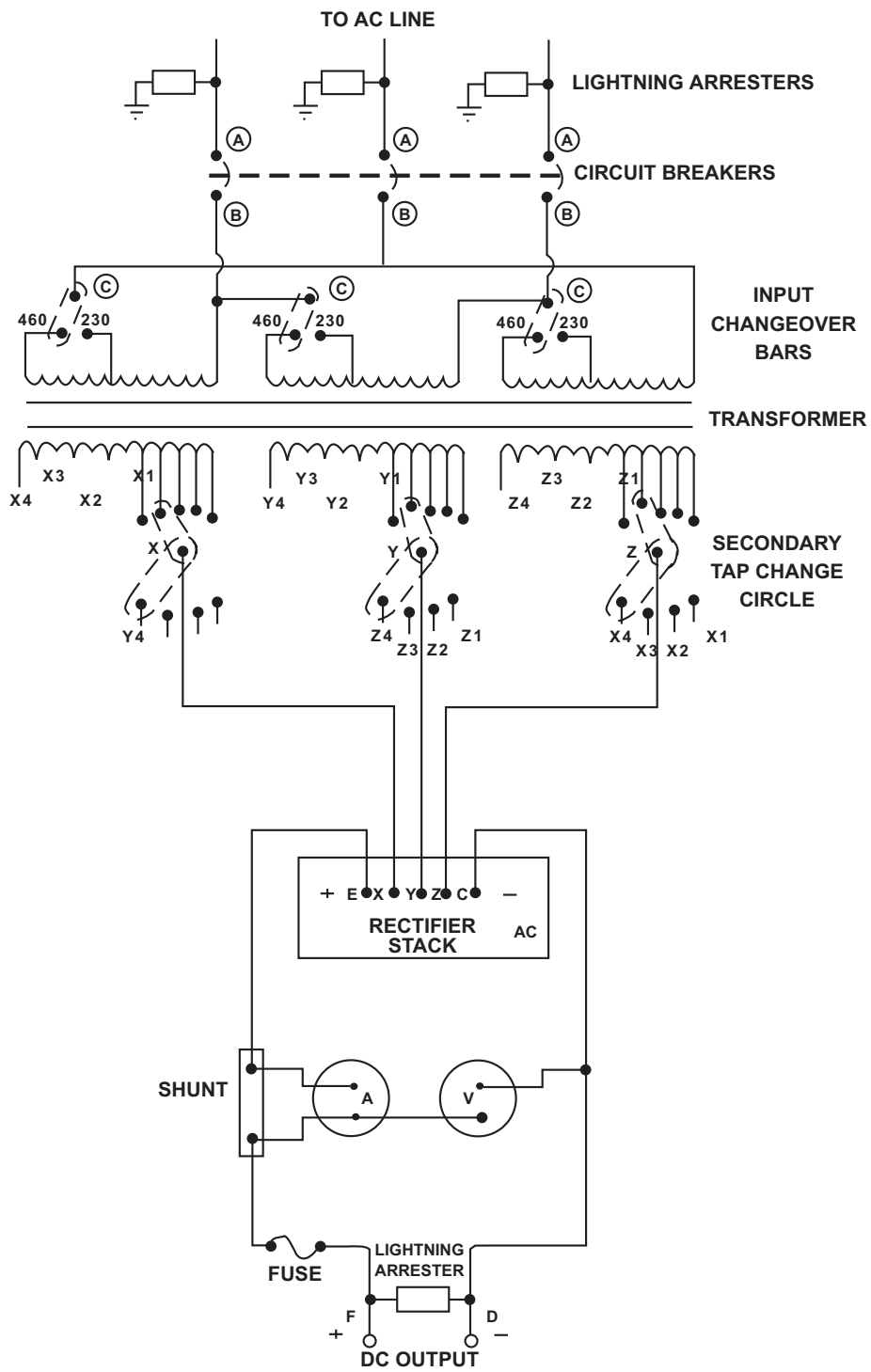

TYPICAL RECTIFIER CIRCUIT

FIGURE 3-15

	Fan Cooled Forced Oil Cooling	Hot Dipped Galvanized Cabinet Anodized Aluminum Cabinet Stainless Steel Cabinet
3. Control Type	Standard Control Current Regulated Voltage Regulated Automatic Potential Control Solid State Control (no taps) IR Drop Free	Cabinet Gauge - 16,14,12,11 Cabinet Legs Cabinet Side Door Slide Out Racks High Ambient Operation Special Taps Coolant - Oil cooled units Non-Standard Access Knockouts AC Frequency - other than 60 hz Elapsed Time Meter Convenience Outlet - 115 volts
4. Rectifying Element	Selenium Bridge Selenium Center Tap Silicon Bridge Silicon Center Tap	
5. Circuit Type	Center Tap, Single Phase Bridge, Single Phase Three Phase Wye Three Phase Bridge Multiple Output Circuit	
6. AC Input	115 volts 230 volts, single or 3 phase 460 volts, single or 3 phase 115/230 volts 230/460 volts, 3 phase 115/460 volts	
7. DC Volts	Specify maximum DC output in volts	
8. DC Amperes	Specify maximum DC output in amperes	
9. Options	AC and DC Lighting Arresters AC Arresters only DC Arresters only Communications Filter Efficiency Filter (choke) Meter Switches Pilot Light DC Failure Light DC Fuse Painted Cabinet	

JUNCTION AND RESISTOR BOXES

Junction boxes are an extra enclosure for terminating large numbers of anode cables to a common electrical bus bar. The rectifier positive cable is fed through a conduit to the main anode bus and a perpendicular bus terminates the lead wires at individual terminals. Leads may be attached to fixed value current limiting resistors and the current output can be measured by connecting a DC voltmeter across each respective shunt. The negative cable from the rectifier is directly attached to the structure and is not normally brought into the box. See Figure 3-16.

Where several anode circuits are supplied from one power supply, it may be desirable to control the current to each anode using variable resistors connected in series with the output cable. Many of these control options can now be built into the rectifier circuitry.

PERMANENTLY INSTALLED REFERENCE ELECTRODES

There are 3 types of reference electrodes that are used for monitoring the potential of a structure or as a sensor in conjunction with potentially controlled rectifiers. They are:

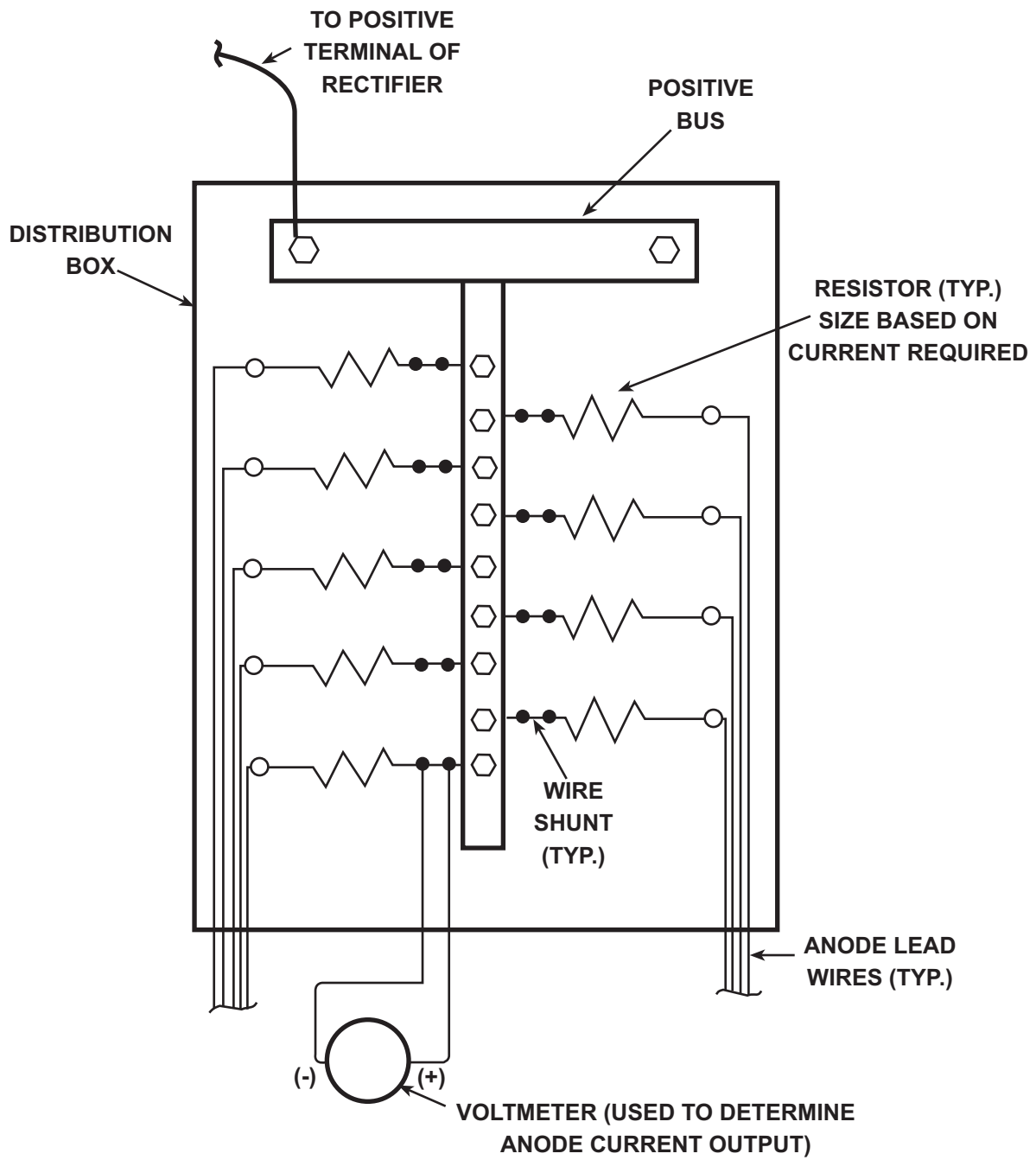

TYPICAL JUNCTION BOX WITH SHUNTS

FIGURE 3-16

High Purity Zinc

Copper/Copper Sulfate Electrode

Silver/Silver Chloride Electrode

If the electrode is to be buried, it must be surrounded with special backfill to increase the ion trap area. Zinc is particularly subject to the effects of polarization and should be surrounded with a 75/20/5 mixture of prepared backfill to prevent this passivation effect.

Copper bearing electrodes with a saturated sulfate solution will become contaminated in the presence of chlorides and are limited to fresh water and chloride free environments for maximum life.

Silver bearing electrodes with a saturated chloride solution are used in sea water and brackish waters where chlorides are found. Other types utilize a perforated plastic tube containing a chloridized silver rod and depend on the natural chlorides in sea water to provide meaningful readings. This second type will give erroneous readings in brackish waters due to the constant changes in chloride levels.

TEST STATIONS

As simple as a test station is, it seems to cause a great deal of confusion, particularly to those people who are unfamiliar with the concept of cathodic protection. The variables are many and here is a partial listing of the variations.

- 1. Box Type**
 - Choices**
 - Post Mount
 - Flush Mount
 - Flange Mount
 - Round
 - Square
 - Explosion Proof -
Specify Type, Class
 - Condulet
- 2. Construction**
 - Polycarbonate
 - Flake Filled Polyester
 - Cast Iron
 - Cast aluminum

ABS Polymer
Thermosetting
Composite

- 3. Terminals**
 - Specify Number
 - Plated Brass
 - Copper
 - Brass
 - Banana Plugs
 - Stainless Steel
 - Lock Washers
- 4. Hub Type**
 - Slip Fit, size
 - Threaded, size
 - Double Hub
 - Single Hub
- 5. Hub Size**
 - Specify size and quantity
- 6. Post Type**
 - Treated wood, size
 - PVC Conduit, size
 - Steel Conduit, size
 - With or without anchors
- 7. Post Length**
 - Specify Length
- 8. Flush Type**
 - Cast Aluminum Top
 - Cast Iron Top
 - Plastic Top, magnetic
- 9. Wiring**
 - None
 - Pre-wired, specify size,
length, insulation
 - Shunts - specify quantity,
size, type
- 10. Covers**
 - Name cast on top
 - "O" Ring Seal, round only
 - Weather Proof Seal
 - Waterproof Seal
 - Slip Fit
 - Exposed Terminals
 - Locking Type
- 11. Terminal Blocks**
 - Polyester Laminate - 0.125"
 - Polycarbonate
- 12. Options**
 - Shorting Bars - specify
quantity, material
 - Lightning Arresters -

- specify type
- Fixed Current Limiting
- Resistors -
 - specify amperage
- Variable Slide Wire
- Resistor - specify amperage
- Rotary Rheostat -
 - specify amperage
- Meters - specify type, range
- Locking Devices
- Shunts - specify amperage

Figure 3-17 shows some typical test stations.

FLANGE ISOLATORS AND DIELECTRIC UNIONS

To isolate cathodically protected structures requires the mechanical insertion of nonconductive materials between the metal components. The isolation material should not deform or deteriorate due to the operational conditions of the external or internal environment or the structure itself. Once again, there are a wide variety of materials to choose from depending on the particular application.

Flange gaskets (Figure 3-18) are selected on the basis of pipe size, ANSI pressure rating, full face or raised face, and material composition to suit the pipeline product. The components of a flange isolation kit consist of a gasket, sleeves, isolating washers, and steel washers.

Components

1. Size

- Specify

2. Gasket Type

- Full Face "E" (with bolt holes)
- Ring "F" (without bolt holes)
- "D" for RTJ flanges

3. Materials

- Plain Phenolic - 225° F, max.
- Neoprene Faced Phenolic - 175° F, max.
- Glass/Phenolic - 350° F, max.
- Aramid Fiber - 450° F, max.

- Epoxy/Glass - 350° F

4. Sealing Element

- Nitrile Sealing Element - 250° F, max.
- Viton - 350° F, max.
- Teflon - 450° F, max.

5. Pressure Rating

- ANSI Class - 150 lbs to 2500 lbs

6. Isolating Sleeves

- Polyethylene - 180° F, max.
- Phenolic - 225° F, max.
- Mylar - 300° F, max.
- Acetal - 180° F, max.
- Nomex - 450° F

7. Isolating Washers

- Glass/Phenolic - 300° F
- High Temp. Phenolic - 350° F
- Silicon/Glass - 350° F
- Epoxy/Glass - 280° F to 350° F

8. Steel Washers

- Cadmium Plated, 1/8" thick

Check with the manufacturer for more specific and absolute data. Flange isolation kits are best suited for above ground electrical isolation on new installations.

Dielectric isolating unions (Figure 3-19) perform the same basic function as flange gaskets by inserting a high resistance plastic between the union faces. They are normally available as "O" Ring Type or Ground Joint Type in pressure ratings of 150 to 3,000 psi working pressure. Common installations include hot water heaters, service station pumps, natural gas distribution service lines, and hydraulic lines.

MONOLITHIC WELD IN ISOLATORS

Monolithic weld in isolators are factory assembled, one piece, isolating devices designed to eliminate underground isolating flanges. They eliminate bolts and washers therefore providing a uniform surface to easily apply an exterior dielectric coating.

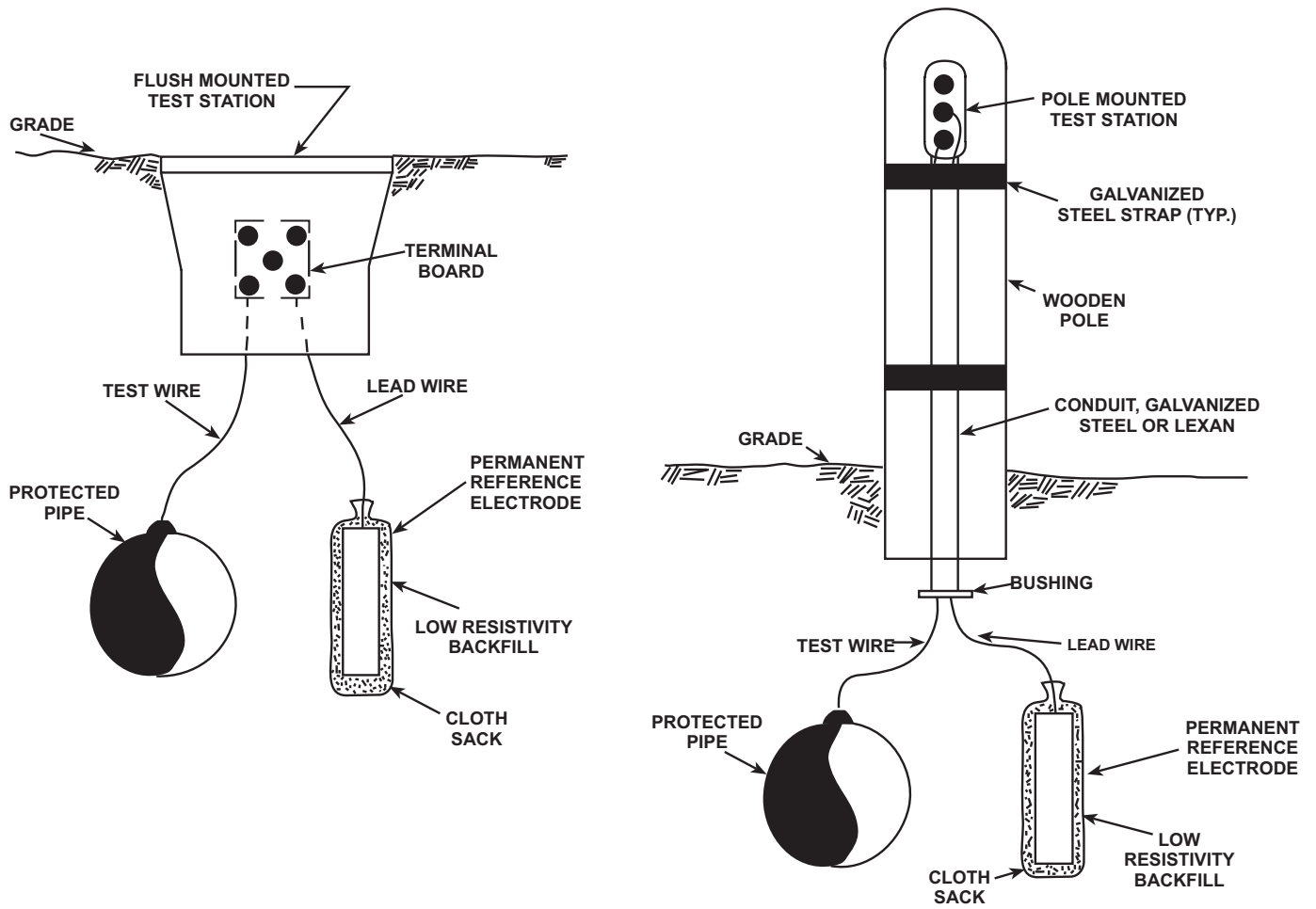

**TYPICAL CATHODIC PROTECTION SYSTEM
TEST STATION INSTALLATIONS**

FIGURE 3-17

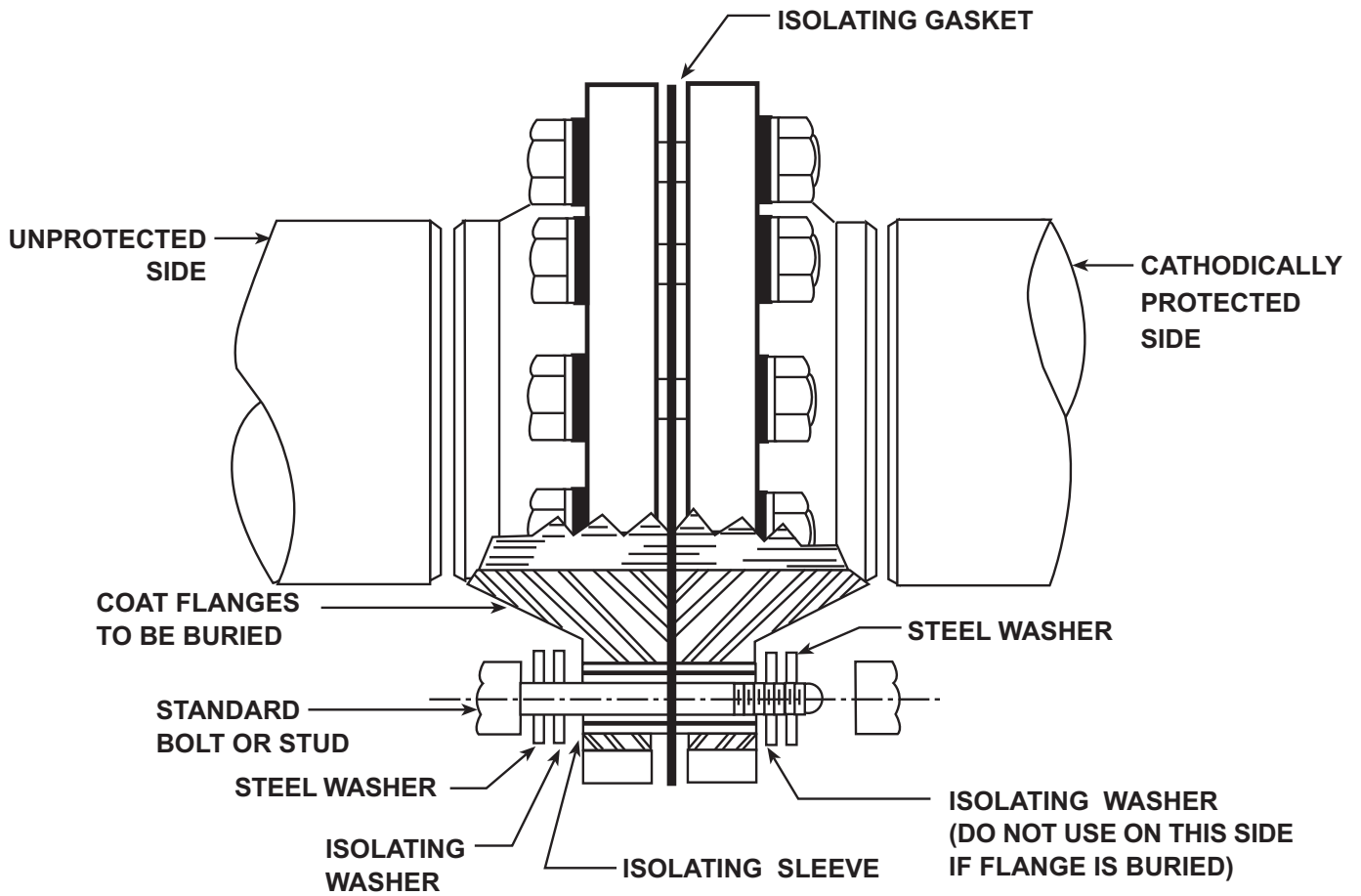

TYPICAL ISOLATING FLANGE ASSEMBLY

FIGURE 3-18

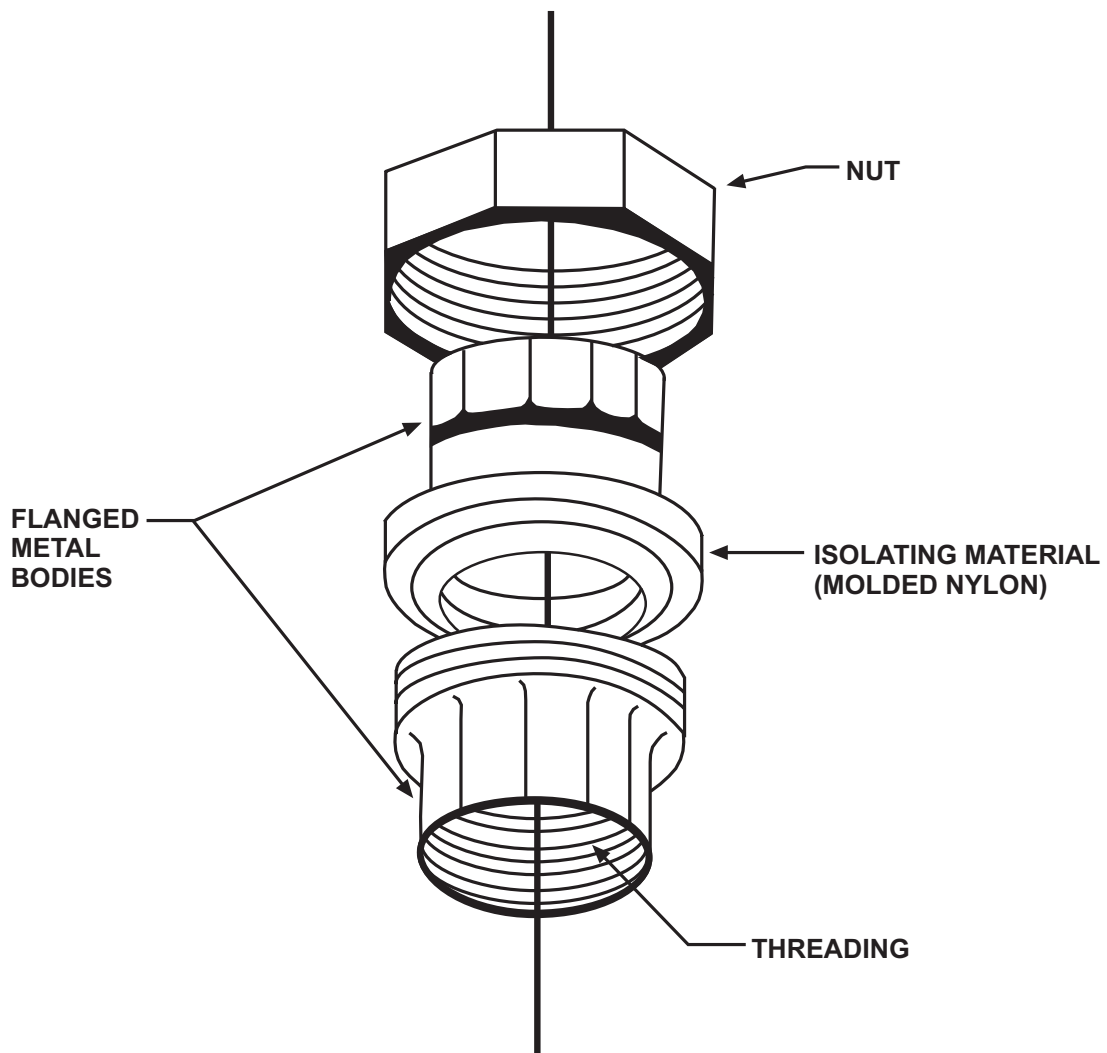

TYPICAL ISOLATING UNION DETAIL

FIGURE 3-19

They are available in pipe sizes up to 120 inches diameter in all ANSI pressure ratings. Factory pretested, they assure high dielectric qualities and are available with an internal coating to reduce bridging of the insulating gap when the product carried in a conductive liquid.

CASING ISOLATORS AND END SEALS

In the mid-1980's, the effects of electrically shorted casings received wider attention from regulatory agencies, due to some unfortunate incidents. The cause and effect relationship of electrically shorted casings should be well known to the reader by now, and the purpose of this section is to acquaint the reader with the types of materials that are currently available. Careful selection and installation of the components during construction, either new or rehabilitative, will reduce the possibility of a shorted casing.

Casing isolators (Figure 3-20) generally consist of molded polyethylene segments, joined together to form rings at frequent intervals on the pipe, to support the weight of the pipe with product and keep the carrier (product line) centered in the casing. On occasion these segments become damaged during installation or during operation due to soil shifting and pipe movement, resulting in a shorted condition.

Other types are made of steel, shaped like a saddle, and are lined with a thick rubber or PVC sheeting to isolate the carrier pipe from the saddles. These too may become damaged and ineffective as mentioned previously if not properly specified. To order, specify a high compressive strength runner suitable for the pipe and product weight and the length of the casing or crossing. The isolator should have a quality coating and be properly designed for the particular project.

Another form of casing isolation is a nonconductive wax filler, used in conjunction with isolating rings, to fill the annular space between the carrier and the casing. If done properly, the filler will prevent ground water penetration and condensation from filling the

space with electrolyte, thus preventing ion flow. It will also prevent atmospheric corrosion attack from occurring within the casing.

If the casing has been in service, it should be flushed with water to remove debris. The end seals are usually replaced with new seals that can accommodate the weight and installation pressures encountered during the filling procedure. For new and rehabilitated casings, the vents are temporarily sealed off and the casing is pressurized to determine if the filler will be contained.

Complications that may arise are, stitch welded casing, perforated casing, out of round casing, improper seals and constricted vent openings.

Casing end seals (Figure 3-20) have traditionally consisted of rubber boots held in place with hose clamps, shrink sleeves with support skirting, and a proprietary rubber link system. Only careful selection and supervision during installation can prevent the end seals from being the weakest link in the system.

CONCLUSIONS

It is important for corrosion control personnel to understand the characteristics of the various materials and equipment associated with cathodic protection systems.

Before designing a system, the corrosion worker should acquire catalogs from various cathodic protection equipment suppliers to determine what materials and equipment are available and to determine their characteristics.

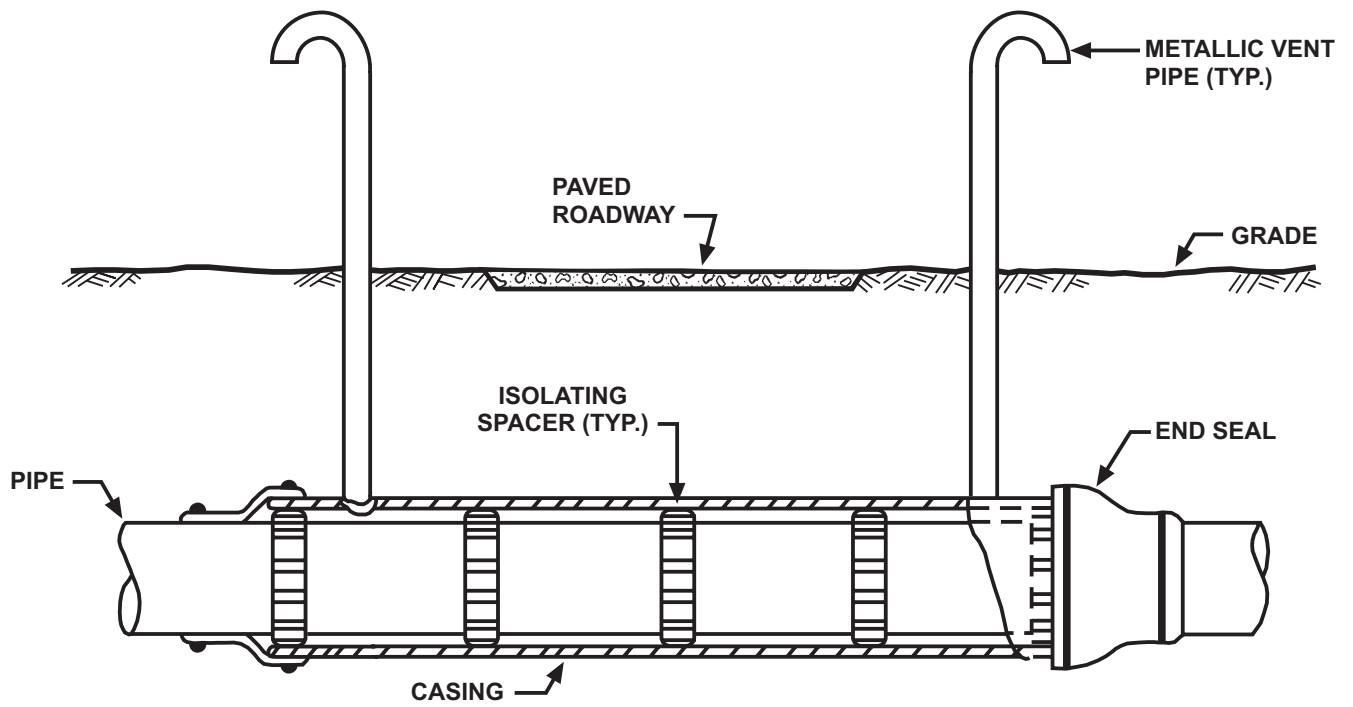

TYPICAL ISOLATED CASING DETAIL

FIGURE 3-20

CHAPTER 4

DYNAMIC STRAY CURRENT ANALYSIS

INTRODUCTION

This chapter will review the causes and common means of detecting and mitigating dynamic stray current effects. Steady state, or static, stray current has been covered in Chapter 5 in the Intermediate Course text.

This chapter presents detailed information on dynamic stray currents emanating from direct current (DC) sources. While alternating current (AC) may create a potential safety hazard, its effect on corrosion of ferrous structures is not fully understood. A brief discussion on stray AC appears at the end of this chapter.

STRAY CURRENTS

Stray currents are defined as electrical currents flowing through electrical paths other than the intended paths. Stray, or interference currents can be classified as being either static or dynamic.

Static interference currents (Chapter 5, Intermediate Course text) are defined as those, which maintain constant amplitude and geographical path. Examples of typical sources are railroad signal batteries, HVDC ground electrodes and cathodic protection system rectifiers.

Dynamic interference currents, on the other hand, are defined as those which are continually varying in amplitude, direction or electrolytic path. These currents can be manmade or caused by natural phenomena. Typical examples of man-made sources are DC welding equipment, electrical railway systems,

chlorine and smelter plants. Telluric, or natural sources of dynamic stray currents, are caused by disturbances in the earth's magnetic field due to sun spot activity. Telluric effects have not been shown to contribute to corrosion, but they do, however, create measurement difficulties and can interfere with one's ability to assess cathodic protection system performance.

THE EARTH AS A CONDUCTOR

In order to understand the control of stray current, one must first understand what these stray currents are. In underground corrosion, we are dealing with the earth as a huge electrolytic medium in which various metallic structures are buried and often interconnected. The earth is an electrolyte because of the water contained in the soils. This water causes ionization of various soluble salts and makes the earth an electrolytic conductor. Conductance is measured in electrical units known as Siemens, or mho centimeters. More commonly, the reciprocal of conductivity, resistivity, is measured and expressed as ohm centimeters. The more conductive the earth, the lower the resistivity. Seawater, for example, has a resistivity of 25 to 30 ohm centimeters. Natural soils, depending on the amount of ionizable material present and the moisture content, range in resistivity from near that of sea water up to the hundreds of thousands of ohm centimeters. When one considers stray currents, it should be borne in mind that the lower the resistivity of the soil, the more severe the effects of stray currents may be.

From the values of resistivity cited, it is quite

evident that a metallic structure in the earth may be a far better conductor of electricity than the earth itself, even seawater. Resistivities for copper and iron are less than 10×10^{-6} ohm centimeters, while that for lead is approximately 22×10^{-6} ohm centimeters. It is readily understandable, therefore, that should current flowing in the earth produce a potential difference (voltage gradient) crossed by such a metallic conductor, the conductor will readily acquire a part of the current that is flowing. See Figure 4-1. Thus, pipelines and cables can become major conductors of stray currents in the earth environment.

POTENTIAL GRADIENTS IN THE EARTH

How do the stray currents that accumulate on metallic structures underground get into the earth? As in any electrical circuit, it is necessary to have potential differences between two points in order to have a current flow. One also must have an electrical circuit, that is, a source of the current and a return for that current. The magnitudes of current will be dependent upon the electrical potential and electrical resistance. The amount of current which will flow on any one structure will be inversely proportional to the resistance of the various parallel electrical paths that join the two points of different electrical potential in the circuit. This is true of any electrical circuit where parallel resistances are involved. A metallic electrode in earth that is positive with respect to the earth around it will discharge current into the earth and onto any other metallic structures that may be in the vicinity. Any element that is negative to earth will have the opposite effect of collecting current from the earth or from metallic structures in its vicinity.

Many companies feel that any positive pipe-to-soil voltage swing of less than 10 millivolts on a structure is tolerable and does not require mitigation, since interference is negligible. The British "Joint Committee for Coordination of Cathodic Protection of Buried Structures", has suggested that the allowable limit of positive change be 20 millivolts. It is possible that positive voltage changes within these ranges

may be indications of strong adverse electrolytic currents, but in the majority of cases where voltage swings are less than 10 millivolts negligible interference exists.

In practice, if the positive swing does not cause a potential less negative than -0.850 volts (IR drop free), then negligible corrosion can be expected.

DETECTION OF DYNAMIC STRAY CURRENTS

The easiest way to keep abreast of possible interference problems in an area is through contact with Corrosion or Electrolysis Coordinating Committees. These committees act as clearinghouses for information on underground plant locations and known interference sources.

Dynamic stray currents are present if the structure-to-soil potential is continually fluctuating while the reference electrode is kept in a stationary position in contact with the soil. See Figure 4-2. These potential changes are a direct result of current changes at the source of the interference due to loading variations. This would also be detected by constantly changing line current measurements (Figure 4-3).

In efforts to locate the source of man-made dynamic stray currents, the following steps should be taken:

1. Determine if any DC electrical railway systems, mines or industrial plants (aluminum, chlorine, etc) exist in the area where the interference was detected.
2. Inquire of other pipeline operators, cable operators or corrosion committees in the area if any dynamic earth current sources in the area, such as rapid transit systems or electrical DC substations exist.
3. If there are mines or DC railways in the area, contact them to determine the location of their operations and current sources.

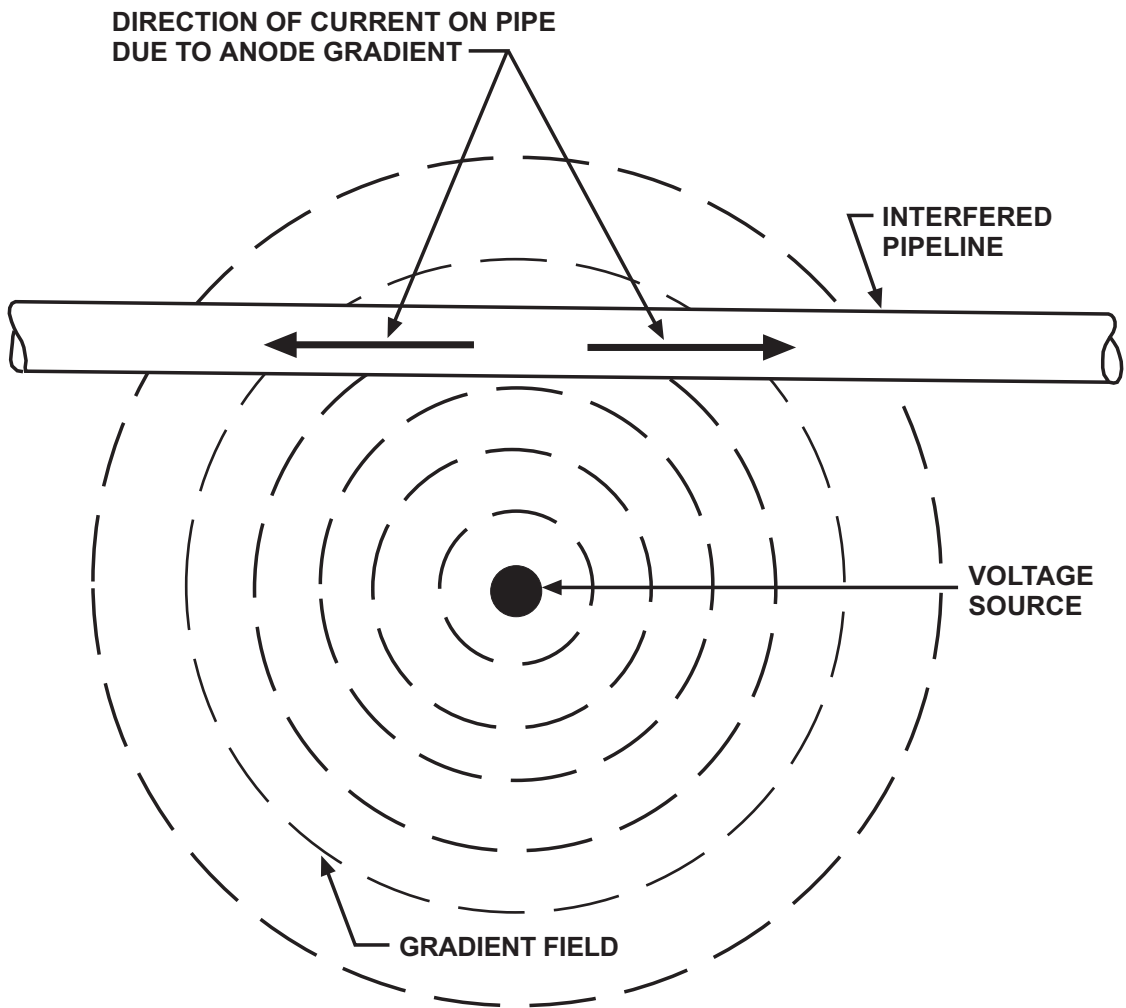

**CURRENT FLOW CAUSED ON STRUCTURE
WITHIN A VOLTAGE GRADIENT FIELD**

FIGURE 4-1

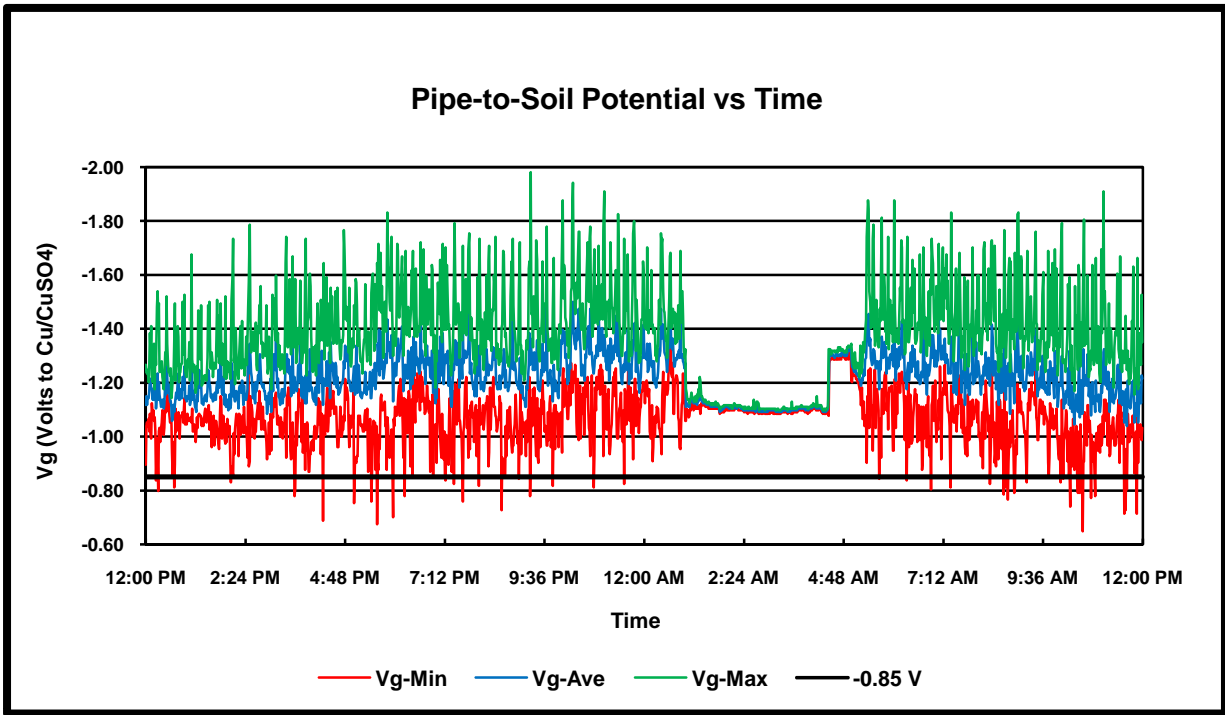

**TYPICAL PIPE-TO-SOIL POTENTIAL (Vg) PROFILE
INDICATING DYNAMIC STRAY CURRENT**

FIGURE 4-2

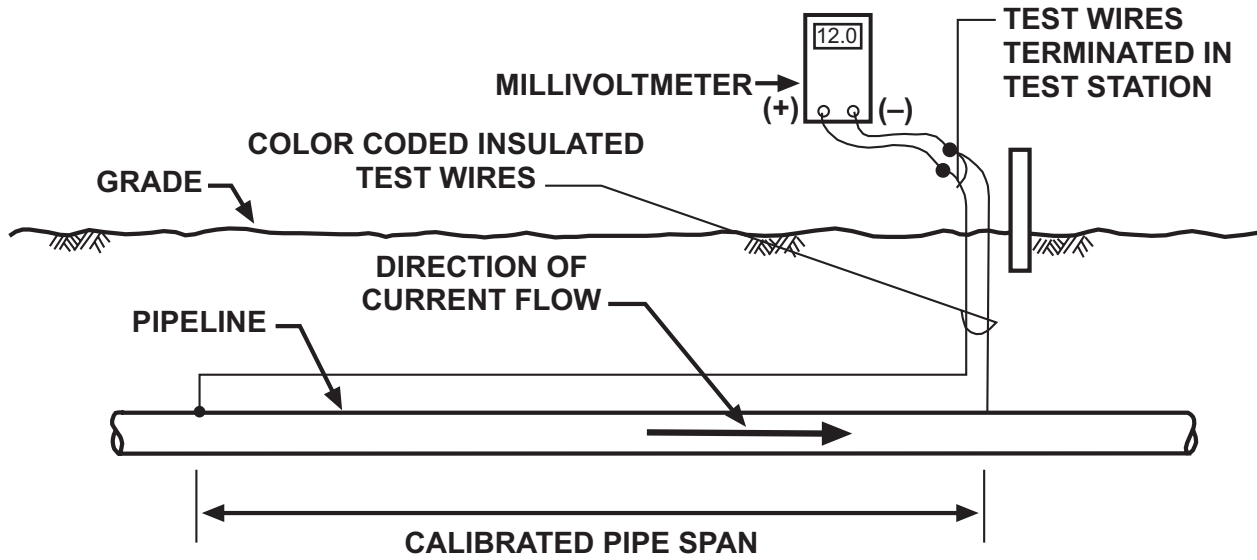

NOTE: POSITIVE POTENTIALS MEASURED WITH METER HOOK-UP AS SHOWN INDICATES CURRENT FLOW IN DIRECTION SHOWN

DETERMINING DIRECTION OF LINE CURRENT FLOW

FIGURE 4-3

- Trace the current flow along the structure back to its source. This can be done by observing the current flow at intervals along the interfered structure by utilizing millivolt drop test station lead wires, to determine the direction of the current flow. This technique is illustrated in Figure 4-3.

Let us assume that a situation exists where a single generating unit is causing interference problems. A voltmeter connection, to be used for pipe-to-soil potential (V_{gsc}) measurements, is made between the pipeline and a reference electrode, somewhere within the earth current pattern of the generator and its load. Observing the fluctuating potential readings at this point alone would not enable one to determine if the readings are being taken at a point where the pipeline is picking up or discharging current. If measurements are being taken at a point of current pickup, a negative potential swing would occur. A positive swing would indicate a decrease of current flow and a condition of the pipe returning to its steady state condition. Readings observed at a discharge point, swinging in the positive direction would indicate an increase in current leaving the line and a negative swing would indicate a decrease in current discharge.

The determination of whether test locations are either pick-up or discharge points is done by obtaining correlations of the pipe-to-soil potential to the open circuit voltage between the interfered pipeline and the stray current source. This is known as a Beta Plot. Figure 4-4 illustrates a typical Beta plot measurement connections. The locations for the pipe-to-soil measurements may be remote from the open circuit measurements. Communication must be established between the locations, as both measurements must be made simultaneously. Sufficient data points must be obtained to indicate trends in the data. Figure 4-5 is an example of a Beta Plot of one location indicating a current pick up area and Figure 4-6 shows a current discharge area at another location.

As the connection shown in Figure 4-4

indicates, a positive value for E_{sc} occurs when current flows from the stray current source to the pipeline. Conversely, a negative value of E_{sc} indicates a flow from the pipeline to the stray current source. The slope of a straight line drawn through the data points is the value of Beta (β):

$$\beta = \frac{\Delta V_{gsc}}{\Delta E_{sc}}$$

As indicated, this type of testing requires that voltage measurements be taken at two different locations. Many readings should be taken at the two locations simultaneously. The meters used at the two locations must be identical or else comparison of the two sets of readings will be difficult.

In most cases, a dual channel recorder such as an X-Y plotter is used or a multi-channel data logger is used.

Interpreting Beta Curves

Beta curves, which are sloped from the bottom right hand side of the graph to the top left side, would indicate an area of current pick up. What this means is that as the current output of the source increases, the current pick up by the interfered structure also increases. An example of such a curve is shown in Figure 4-5.

An area of current discharge is indicated by a curve which slopes from the bottom left to the top right of the graph, indicating that the rate of current discharge increases as the current output of the source increases. An example of such a curve is shown in Figure 4-6.

If the plotted points describe a vertical line, this would indicate a neutral curve. This means that there is no influence on V_g by the output fluctuations of the current source. Such a curve is rare in practice and if one is plotted, the possibility of equipment malfunctions or errors during testing should be investigated.

If the plotted points do not describe a straight line, this may indicate that the interfered

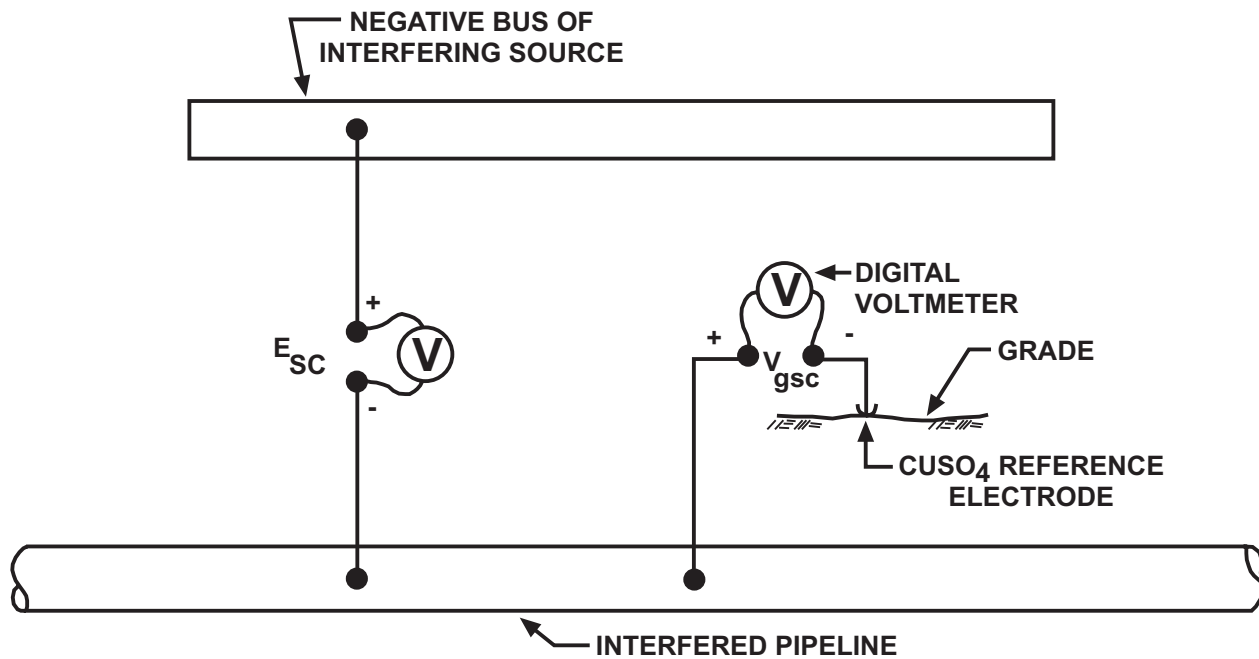

TYPICAL TEST SET-UP USED TO LOCATE
POINT OF MAXIMUM EXPOSURE

FIGURE 4-4

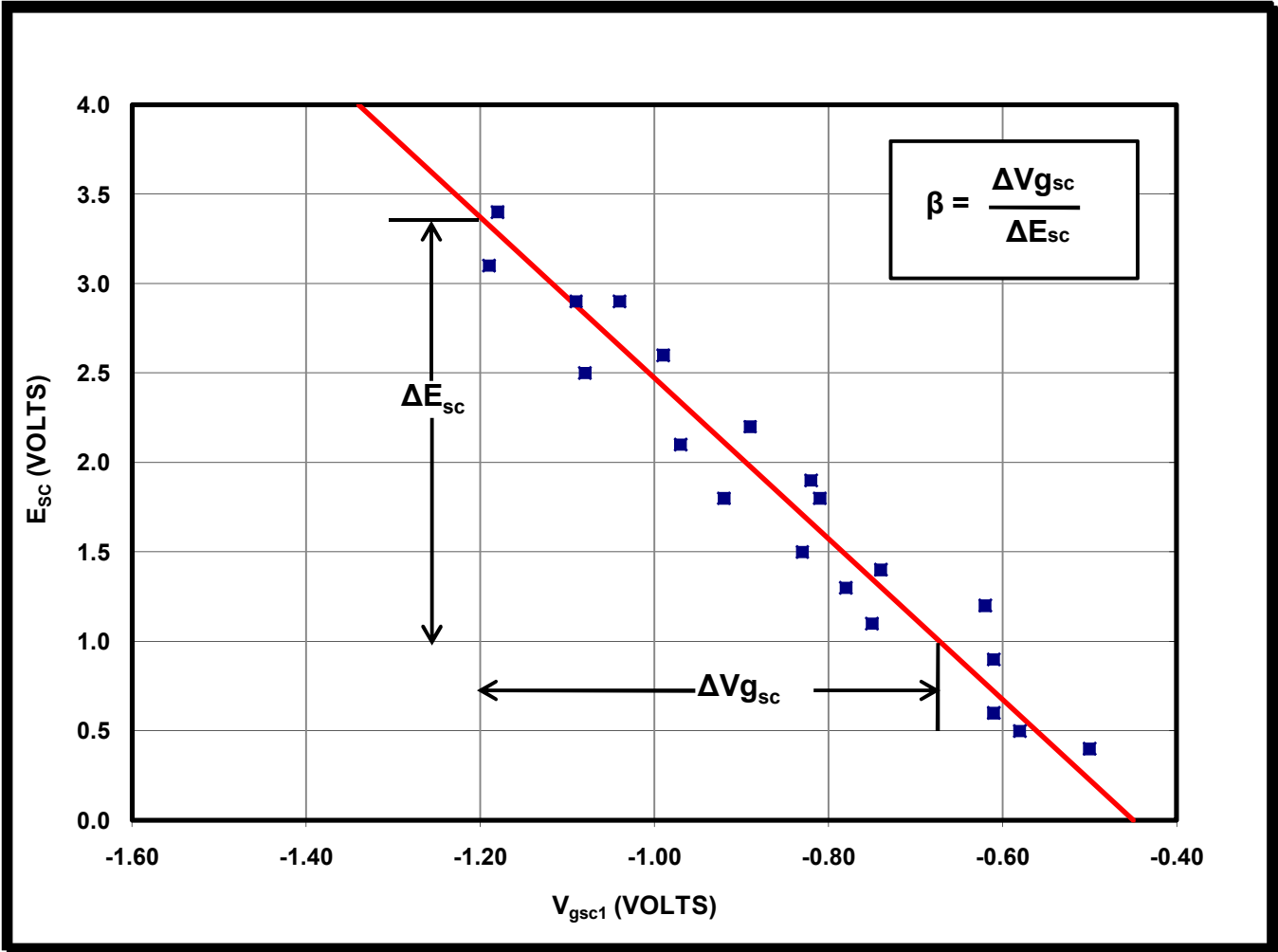

TYPICAL BETA CURVE - PICKUP AREA

FIGURE 4-5

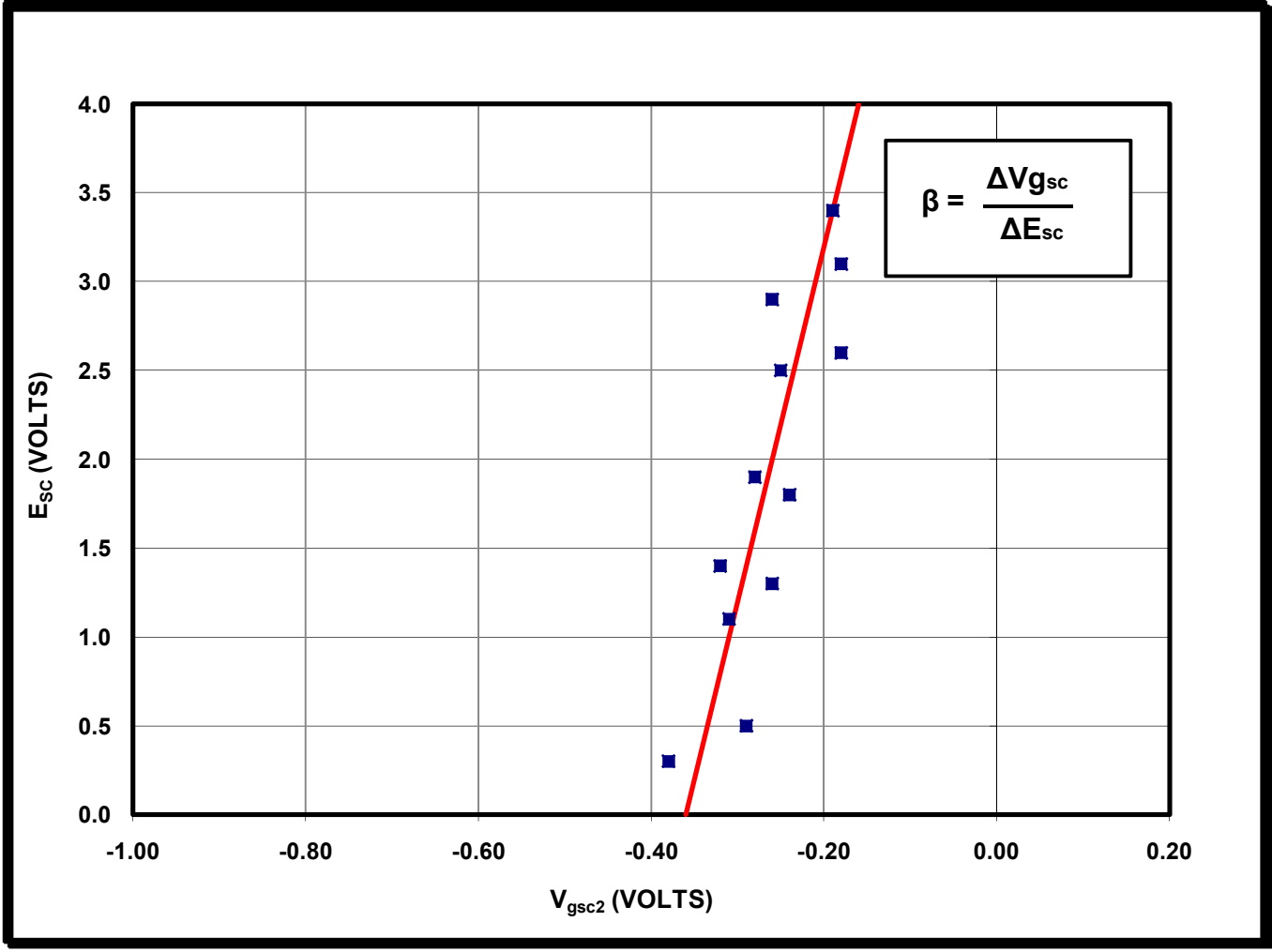

TYPICAL BETA CURVE - DISCHARGE AREA

FIGURE 4-6

structure may be picking up stray currents from an additional source or that the suspected source is not causing the interference. Plots describing two or more distinct lines would indicate the presence of more than one interfering current sources. The slopes of these lines will indicate whether currents are discharging or being picked up according to their slopes and the polarity of the meter connections.

Determining the Point of Maximum Exposure

The point of maximum exposure can be determined based on the slopes of the plotted discharge beta curves. The beta curve which has the most horizontal (largest) slope indicates the location of maximum exposure. Figure 4-7 shows this graphically.

In practice, the calculated slopes can be plotted versus distance to indicate clearly the location of the largest slope (indicative of the most horizontal line).

METHODS OF MITIGATING THE EFFECTS OF DYNAMIC STRAY CURRENT

There are several general methods used to reduce or mitigate the effects of dynamic stray current. These methods include: control at the source, installation of mitigation bonds and reverse current switches, use of sacrificial anodes, and use of impressed current cathodic protection to counter the stray current. Each of these methods is discussed in the following sections.

Controlling Stray Currents at the Source

The most effective way to minimize dynamic stray current is to minimize the electrical current entering the earth in the first place. In the case of transit and any other systems involving rail returns, the best procedure is to ensure that the rails are installed with insulated fasteners on well-ballasted roadbeds or concrete invert. The DC negative bus of the traction power substation should be ungrounded, and the

substations should be spaced at a maximum of about one-mile apart. Modern rail transit systems use welded rail; this reduces the voltage drop in the rail, which in turn reduces the stray current induced in the earth.

Similarly, when dealing with equipment, if isolated electrical positive and negative circuits can be used, stray current problems will be avoided because the currents never reach the earth. When welding is done, care should be taken to assure that the welding electrode and the ground are relatively close together and the electrical path between them is of negligible resistance. Thus, no voltage drop of any significance will exist between them.

Mitigation (Drainage) Bonds and Reverse Current Switches

Mitigation bonds and reverse current switches are used to mitigate the effects of stray current corrosion on a structure.

The purpose of a mitigation, or drainage bond is to eliminate current flow from a metallic structure into the electrolyte by providing a metallic return path for such current. The drainage bond will allow the stray current to flow through the structure and back to the source, through the bond. Figure 4-8 shows the typical current flow when a drainage bond is installed. As a result, corrosion will not occur if the current is not allowed to flow from the metal surface into the electrolyte.

It is not good practice to install drainage bonds on modern rail transit systems that have been designed to minimize stray current at the source. The high resistance to ground of these systems minimizes stray current. Installation of a bond lowers this resistance and in turn increases stray current flow.

When designing a bond, the goal is to find the proper size resistance to be inserted between the affected structure and the source so that stray current discharge into the electrolyte is eliminated at all points. The proper bond will cause the affected structure to return the pickup

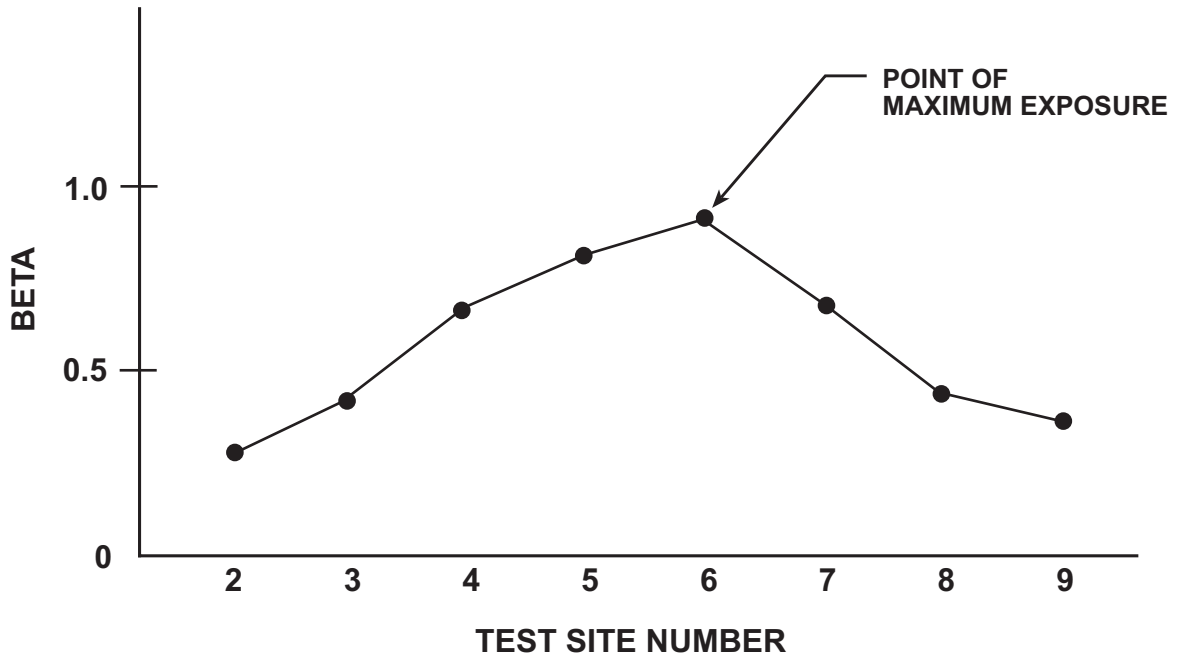
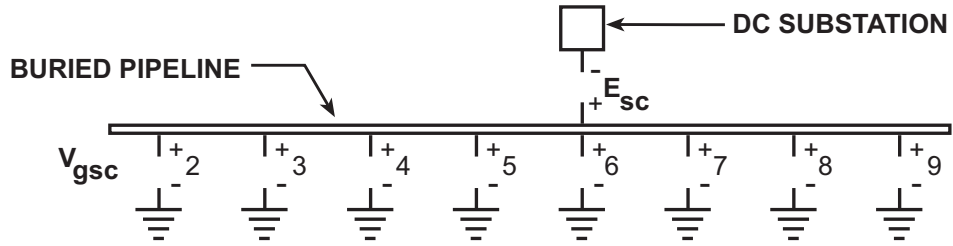

**LOCATING THE POINT OF MAXIMUM EXPOSURE
FROM A BETA PROFILE**

FIGURE 4-7

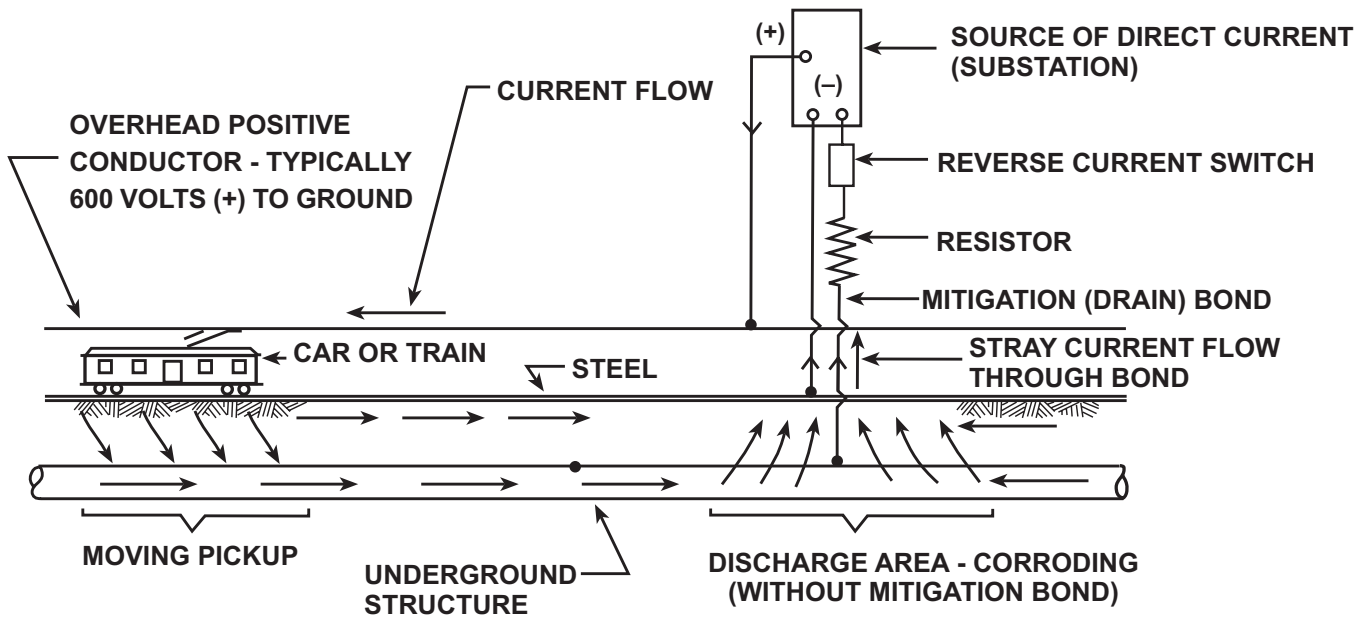

**INSTALLATION OF A MITIGATION BOND ON A
DC TRANSIT SYSTEM TO PREVENT
STRAY CURRENT CORROSION**

FIGURE 4-8

current to the interfering structure through the bond.

Before the mitigation bond can be sized, the point of maximum exposure must be located. This is done as described earlier under "Determining the Point of Maximum Exposure".

As previously indicated, dynamic stray current testing requires potential measurements taken simultaneously at two different locations. These readings can be taken by two technicians who are in communication with each other by radio so that one can tell the other when to take a reading. Many readings should be taken at the two locations simultaneously. Meters used at the two locations must have identical characteristics or comparison of the two sets of readings will be difficult.

To facilitate the taking of these potential readings, strip chart recorders can be set up at the two locations. Recordings obtained over a 24-hour period will normally provide all the data required. The corresponding readings taken at the two locations can then be plotted on linear graph paper. This plot of points is known as a "beta curve". Several locations should be tested longitudinally along the pipeline within the exposure area. The location of the recorder at the source remains constant. A separate set of simultaneous readings should be made at each test location. This type of survey is known as a beta profile.

State-of-the-art computerized multi-channel test equipment is available to facilitate obtaining a beta profile. These computerized recorders can be set to record the potentials at as many as 28 different locations simultaneously for any desired length of time. The recorder will store all readings in a permanent memory until it is down-loaded into a computer terminal. Computer programs are available which will then plot beta curves. Similarly X-Y recorders, which simultaneously record pipe-to-soil potential and pipe to source voltage are frequently used.

The points when plotted should describe a

straight-line plot referred to as the beta curve. The slope of the plotted line will indicate whether the interfered structure in the area of the test is picking up current, discharging current or neither.

Once the location of maximum exposure is determined and its negative slope or beta curve plotted, the size of the resistance bond can be determined. The required size of the resistance bond is such that its installation will cause the beta curve at the point of maximum exposure to assume a neutral or pick-up slope. Figure 4-9 shows a beta curve at a point of maximum exposure as well as the required mitigation curve.

Sizing the Mitigation (Drain) Bond

Two methods are available to size the bond, trial and error and mathematical. Both are explained below.

Trial and Error Method

In relatively simple cases, such as where a single source of stray current is involved, a trial and error solution may be possible. The size of the resistance bond can be determined by installing temporary cables and variable resistors and determining when stray current corrosion has been mitigated. Since drain currents of up to 200 to 500 amperes can be involved, test cables must be sized accordingly. A mitigation curve such as that shown in Figure 4-9 must be obtained from the test bond.

When using the trial and error method on stray current problems involving transit systems, care should be exercised to ensure that the temporary bond does not affect signaling.

Mathematical Method

Where a more complex interference problem exists that precludes the use of the trial and error method, the following mathematical method can be used to size the resistance bond. As noted earlier, dynamic stray currents may involve large values of current flow, so the

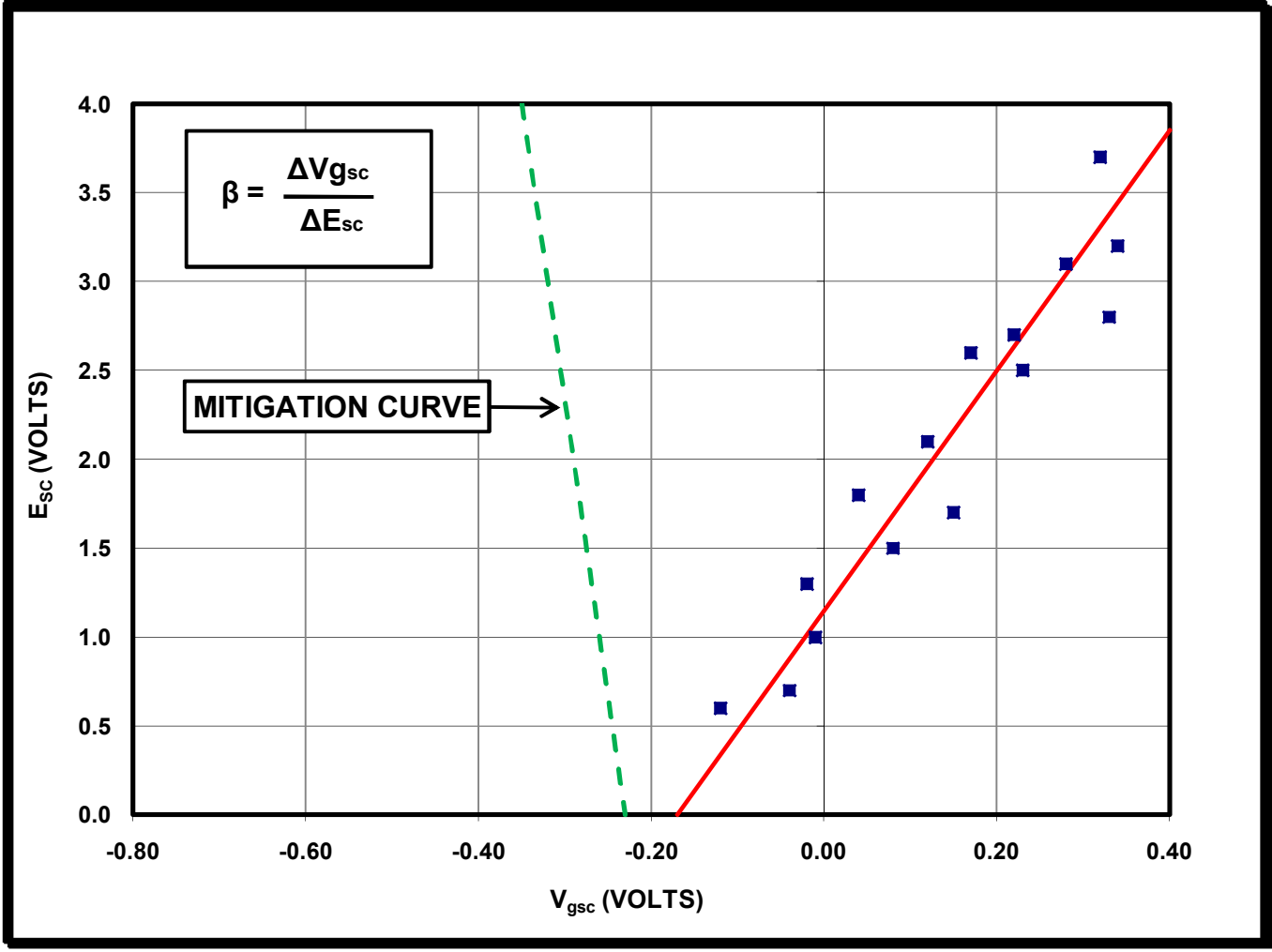

TYPICAL BETA CURVE - DISCHARGE AREA
(MITIGATION CURVE)

FIGURE 4-9

anticipated currents must be known to size cable and associated electrical equipment properly. A mathematical solution can provide the designer with these anticipated values.

This method is based upon the electrical relationships between the source and the pipeline. The measured potential-to-earth of a pipeline is a combination of its natural potential-to-earth plus the sum of all potential changes caused by the DC sources influencing it.

The test set ups for the mathematical method are shown in Figures 4-10 and 4-11. Figure 4-10 explains the test procedure for determining the internal resistance (R_{int}) between the pipeline and the stray current source. Figure 4-11 shows the procedure to determine the change in pipe to soil potential per ampere of drain current.

The beta curve at the point of maximum exposure, such as the one shown in Figure 4-12, is plotted. The equations used in reaching the solution are as follows:

Equation 1

$$V_g = \Delta V_{go} + \Delta V_{gcp} + \Delta V_{gsc} + \Delta V_{gb}$$

Where:

V_g = Pipe-to-soil potential with all current sources operating

ΔV_{go} = Natural pipe-to-soil potential of the pipeline

ΔV_{gcp} = Change in pipe-to-soil potential caused by cathodic protection of pipeline

ΔV_{gsc} = Change in pipe-to-soil potential caused by stray current sources

ΔV_{gb} = Change in pipe-to-soil potential caused by mitigation bond

In the case of a dynamic stray current:

Equation 2

$$\Delta V_{gsc} = \beta \times \Delta E_{sc} \text{ (See Figure 4-4)}$$

Where:

$$\beta = \Delta V_{gsc} / \Delta E_{sc}$$

If no cathodic protection is present, Equation 1 simplifies to Equation 3:

Equation 3

$$V_g = V_{go} + \beta + \Delta E_{sc} + \Delta V_{gb}$$

For the dynamic stray currents to be mitigated:

Equation 4

$$\beta \times \Delta E_{sc} = \Delta V_{gb} \quad (V_g - V_{go} \text{ must} = 0)$$

From Figure 4-12, the value for $V_{go} = 0.570$ volts and β (the slope of the plotted points) = 0.017.

ΔV_{gb} is the change in potential-to-soil of the interfered structure caused by a bond current. The value of ΔV_{gb} can be calculated for any given bond current from Equation 5:

Equation 5

$$\Delta V_{gb} = I_1 \times \left(\frac{\Delta V_g}{I_1} \right) \quad \text{(See Figure 4-11)}$$

Combining Equation 4 with Equation 5 yields Equation 6:

Equation 6

$$\beta \times E_{sc} = I_1 \times \left(\frac{\Delta V_g}{I_1} \right)$$

The value of the bond current, I_b , is calculated from Equation 7:

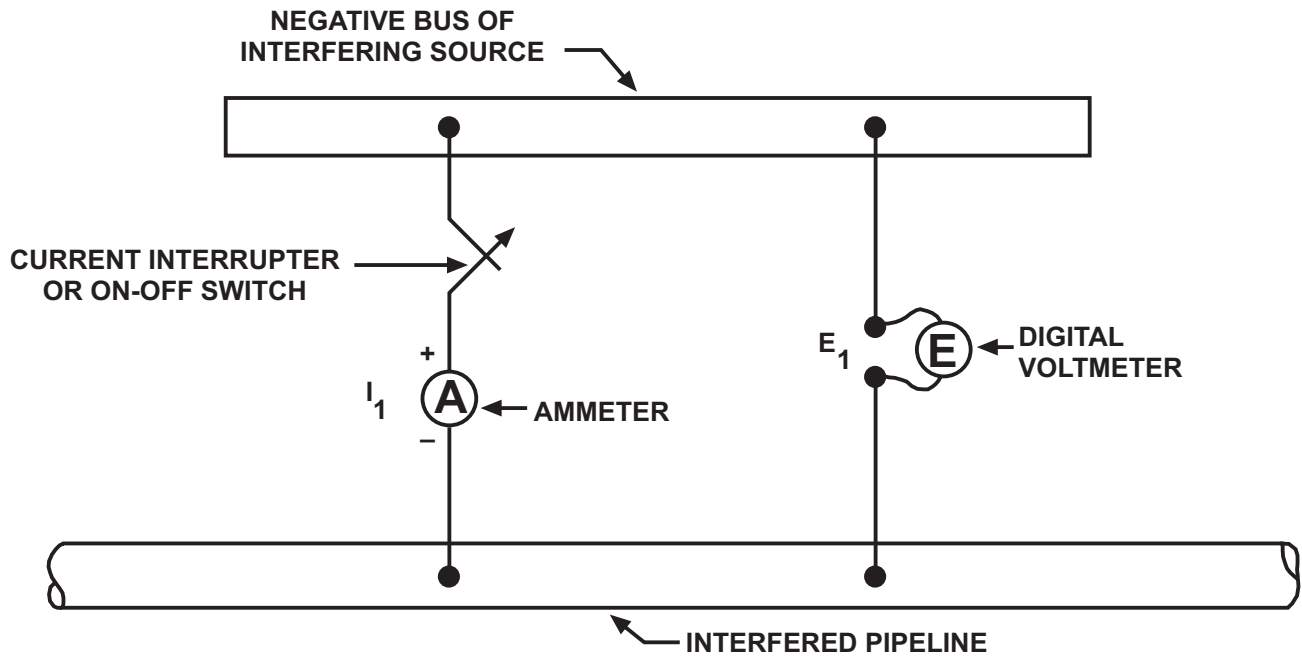

Several sets of data are taken by interrupting the current circuit. Current and voltage are taken simultaneously with the switch closed (on) and open (off: $I_1 = 0$). The resistance between the two structures (R_{1-1}) is calculated from Ohm's Law:

$$\begin{aligned} \Delta E_1 &= E_{1ON} - E_{1OFF} \\ \Delta I_1 &= I_{1ON} - I_{1OFF} \quad (I_{1OFF} = 0) \\ R_{int} &= \Delta E_1 / \Delta I_1 \end{aligned}$$

**TYPICAL TEST SET-UP USED TO DETERMINE
INTERNAL RESISTANCE (R_{int}) BETWEEN
THE PIPE AND NEGATIVE BUS**

FIGURE 4-10

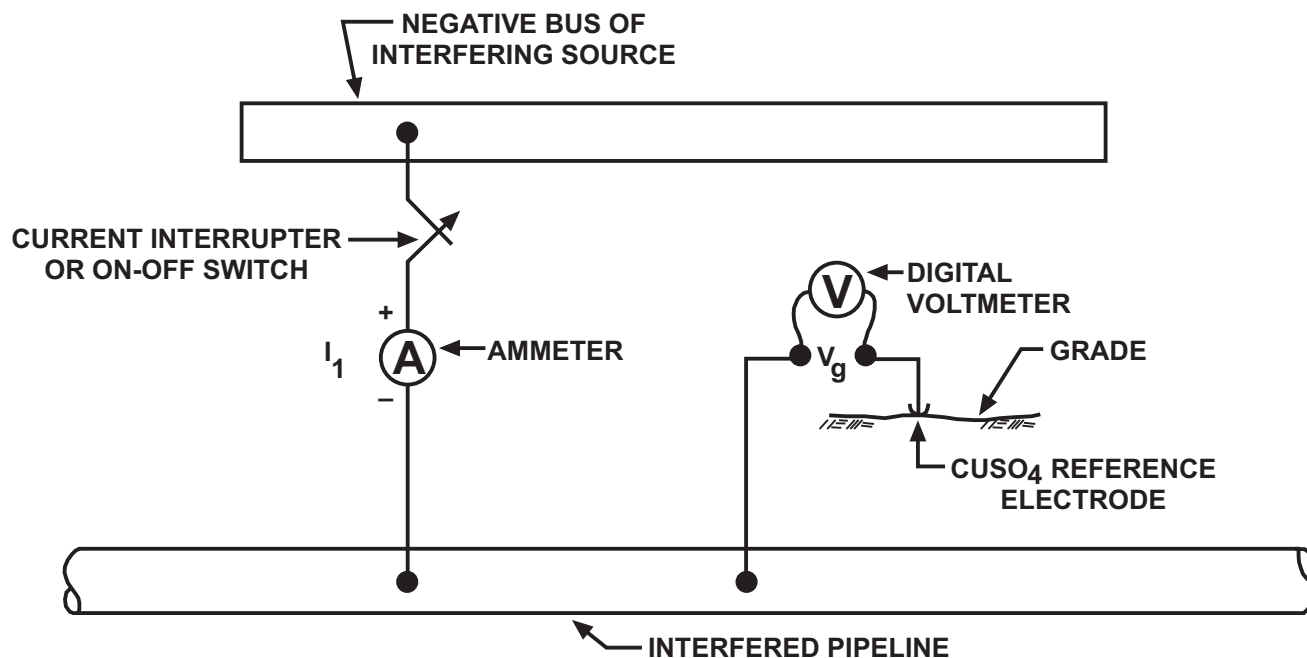

Several sets of data are taken by interrupting the current circuit. Current and pipe to soil potential readings are taken simultaneously with the switch closed (on) and open (off: $I_1 = 0$). The change in pipe to soil potential per ampere of current flow ($\Delta V_g / I_1$) is calculated from Ohm's Law and is expressed as volts per ampere (V/A):

$$\begin{aligned} \Delta V_g &= V_{gON} - V_{gOFF} \\ \Delta I_1 &= I_{1ON} - I_{1OFF} \quad (I_{1OFF} = 0) \\ V/A &= \Delta V_g / \Delta I_1 \end{aligned}$$

**TYPICAL TEST SET-UP USED TO DETERMINE
PIPE TO SOIL POTENTIAL CHANGE PER
AMPERE OF DRAINAGE CURRENT**

FIGURE 4-11

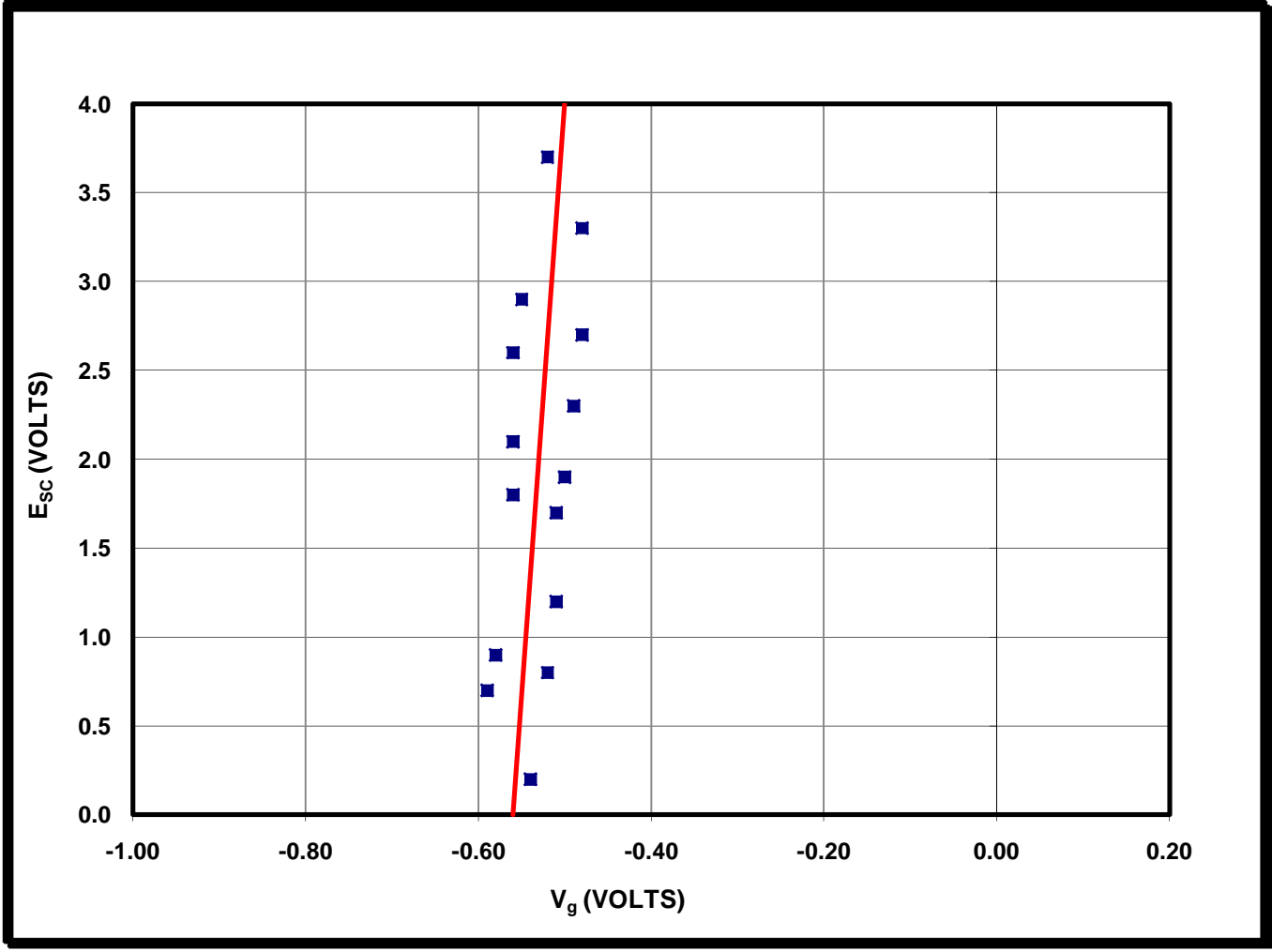

BETA CURVE PLOTTED AT POINT OF MAXIMUM EXPOSURE

FIGURE 4-12

Equation 7

$$I_b = \beta \times E_{sc} / \left(\frac{\Delta V_g}{I_1} \right)$$

The resistance of the bond can be calculated from Ohm's Law:

Equation 8

$$E_{sc} = I_b \times (R_{int} + R_b)$$

Or, rearranging:

Equation 9

$$R_b = \frac{E_{sc}}{I_b} - R_{int}$$

Substituting:

Equation 10

$$R_b = E_{sc} \times \frac{\Delta V_g / I_1}{\beta \times E_{sc}} - R_{int}$$

Or:

Equation 11

$$R_b = \frac{\Delta V_g / I_1}{\beta} - R_{int}$$

Tables 4-1 and 4-2 present sample data for a single bond stray current problem. From Table 4-1, the average resistance between structures is found to be 0.070 ohms. Table 4-2 shows the value of $\Delta V_g / I_1$ to be 0.00169 V/A. Using the β value from Figure 4-12 of 0.017 and substituting the values into Equation 11, the bond resistance, R_b , is calculated:

$$R_b = \frac{0.00169}{0.017} - 0.070 = 0.0294 \Omega$$

The bond resistance value, 0.0294 ohm for this example, can be a simple cable or a combination of cable and variable or fixed resistors. The bond must also be sized to permit the maximum current flow and still remain in the ampacity range for the bond. In a dynamic stray current situation, the maximum current can be calculated once the maximum open circuit voltage between the structures is known. This value is usually obtained by using a recording voltage instrument over several operating cycles of the stray current source to measure the peak value. For most stray current sources the typical cycles is 24 hours.

For example, if the maximum value of open circuit voltage, E_{sc} , is 12.0 volts, substitution of this value into Equation 8 and rearranging the equation gives the value of the maximum stray current through the bond 120.7 amperes as shown below:

$$E_{sc} = I_b \times (R_{int} + R_b)$$

$$I_b = \frac{E_{sc}}{R_{int} + R_b}$$

$$I_b = \frac{12.0}{0.070 + 0.0294} = \frac{12.0}{0.0994}$$

$$I_b = 120.7 \text{ amperes}$$

Table 4-1 also shows some typical measured values for E_1 and I_1 , using the test setup shown in Figure 4-10, as well as the calculated internal resistance.

Table 4-2 also shows some typical measured values for V_g and I_1 , using the test setup shown in Figure 4-11, and the corresponding calculated $\Delta V_g / I_1$.

In many instances of stray current work where traction systems are involved, there may be locations where drainage bonds are required in areas where electrical reversals of potential could occur. Therefore, it is often necessary to

TABLE 4-1

R_{int} Data - See Figure 4-10

	E₁ (Volts)	I₁ (Amperes)	R_{int} (ohms)
On	+1.30	36.0	
Off	-1.15	0	
Delta	+2.45	36.0	0.068
On	+0.80	39.0	
Off	-1.80	0	
Delta	+2.60	39.0	0.067
On	+0.50	41.0	
Off	-2.30	0	
Delta	+2.80	41.0	0.068
On	+2.10	29.0	
Off	0.00	0	
Delta	+2.10	29.0	0.072
On	+2.00	29.5	
Off	-0.15	0	
Delta	+2.15	29.5	0.073
On	+1.30	35.0	
Off	-1.25	0	
Delta	+2.55	35.0	0.073
On	+0.35	43.0	
Off	-2.65	0	
Delta	+3.00	43.0	0.070
Average R_{int} =			0.070

TABLE 4-2

$\Delta V_g/I_1$ Data - See Figure 4-11

	V_g (Volts)	I_1 (Amperes)	$\Delta V_g/I_1$ (V/A)
On	0.645	34.0	
Off	0.590	0	
Delta	0.055	34.0	0.00162
On	0.635	23.0	
Off	0.600	0	
Delta	0.035	23.0	0.00150
On	0.770	82.0	
Off	0.620	0	
Delta	0.150	82.0	0.00183
On	0.770	86.0	
Off	0.625	0	
Delta	0.145	86.0	0.00168
Average $\Delta V_g/I_1 =$			0.00169

install an electrolysis switch or silicon diode into the circuit to prevent current flow from the railroad back onto the pipeline through the bond. The resistance to the forward flow of current created by these devices must be included in the sizing of the bond.

Use of Sacrificial Anodes

Sacrificial or galvanic anodes may be used to mitigate stray current effects in situations where small current flows or small voltage gradients exist. A misconception surrounding the use of galvanic anodes for stray current mitigation states that the anode draws the stray currents and prevents currents from entering into the electrolyte from the interfered structure. This over-simplification does not consider the entire electrical network involved. In effect, a potential gradient field produced by the galvanic anode(s) counteracts the interference current. The effect is a net current flow to the interfered with structure. A version of the electrical circuit is shown in Figure 4-13.

The potential gradients of the stray current source and of the anodes counteract each other. Galvanic anodes produce limited voltages, however, and as such are limited to the stray current voltages, which they can overcome.

Another consideration when using a galvanic anode system to overcome stray currents is the expected life of the anodes. As the anodes dissipate, their resistance to ground increases. The increased resistance reduces the current flow from the anode and decreases the resulting voltage gradients. Sacrificial anodes should be sized to provide a sufficient anticipated life span. As with any other stray current mitigation procedure, the anodes should be placed on an active monitoring schedule.

Galvanic anode drains are commonly used in lieu of bonds where small drain currents are involved. In areas of large current drains, the use of galvanic anode drains would be impractical due to the high consumption rate of the anode material; frequent anode

replacement would be required. Galvanic anodes would also be impracticable where voltage gradients are encountered that are greater than those galvanic anodes can produce.

Use of Impressed Current Systems

When the magnitude of stray currents are beyond the ability of galvanic anodes to counteract, impressed current systems can sometimes be utilized. Impressed current systems have much higher voltage capacities than galvanic anodes and a greater life per pound of anode material. Built-in control and monitoring circuits in the impressed current rectifier can be used to adjust the protective current output based upon the voltage-to-earth fluctuations of the interfered pipeline.

The design of galvanic or impressed current mitigation systems is done by the trial and error method. Simulated systems are placed in the field and the results measured. Based upon the results, a full-scale system can be designed.

STRAY CURRENT FROM ALTERNATING CURRENT (AC) SOURCES

Stray current from AC sources can cause corrosion as well as be a safety hazard. Both steady state and dynamic stray AC current may be found.

Several laboratory and field studies have indicated that above a certain minimum AC current density, normal levels of cathodic protection will not control AC corrosion to acceptable levels and that AC mitigation is often required to prevent serious corrosion.¹ Methods of mitigating AC corrosion are beyond the scope of this text.

Steady state stray AC is most commonly associated with pipelines laid in close proximity and paralleling high voltage AC electrical transmission lines. AC induction on such pipelines can create dangerous voltages. Mitigation of the voltage on the line as well as safety grounding of test stations and above

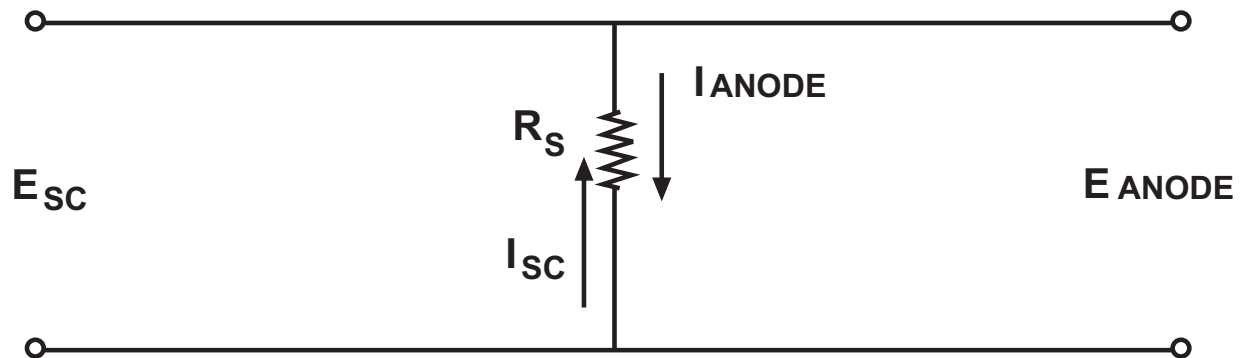

R_s — RESISTANCE OF STRUCTURE TO EARTH
 I_{sc} — STRAY CURRENT
 E_{sc} — VOLTAGE GRADIENT OF STRAY CURRENT

WHEN $E_{ANODE} > E_{sc}$ — GALVANIC DRAINS FUNCTION TO PRODUCE A NET PROTECTIVE FLOW

WHEN $E_{ANODE} < E_{sc}$ — GALVANIC DRAINS INEFFECTIVE

SIMPLE EQUIVALENT CIRCUIT FOR GALVANIC ANODE DRAIN

FIGURE 4-13

ground appurtenances to buried equipotential mats are recommended if the AC pipe-to-soil potential exceeds 15 volts.

Dynamic AC stray currents may be generated by AC welding operations, bad grounds in buildings or AC electrified railroads.

For information on AC mitigation, the reader is referred to NACE Standard Practice SP0177-2007 "Mitigation of Alternating Current and Lightning Effects on Metallic Structures and Corrosion Control Systems".²

CONCLUSIONS

Stray current interference on a pipeline can cause severe local corrosion that could lead to a hazardous situation, product leakage and costly repairs. Therefore, every effort should be made to avoid interference problems and, if they exist, to mitigate their effects.

Stray currents can be classified as being either static or dynamic. Static interference currents are defined as those, which maintain a constant amplitude, direction and electrolytic path. Dynamic interference currents are defined as those, which continually vary in amplitude, direction and electrolytic path. Static interference is always caused by man-made sources; dynamic interference, however, can also be caused by telluric activity.

Stray current control at the source is the best method of stray current mitigation.

The use of bonds or cathodic protection systems to mitigate stray current corrosion can be very effective when properly designed and installed. It is very important that all field testing and remedial actions be conducted or taken in the presence of, or with the permission of, representatives of all companies/owners involved.

Sacrificial anode or impressed current cathodic protection can also be used to mitigate stray current.

Stray AC can cause corrosion and be a safety hazard.

REFERENCES

1. R. A. Gummow, "AC Corrosion – A Challenge to Pipeline Integrity," *Materials Performance*, 38, 2 (Feb. 1999)
2. NACE Standard Practice SP0177-2007 "Mitigation of Alternating Current and Lightning Effects on Metallic Structures and Corrosion Control Systems", NACE International, Houston, Texas

CHAPTER 5

DESIGN OF IMPRESSED CURRENT CATHODIC PROTECTION

INTRODUCTION

The objective of this chapter is to provide corrosion control personnel with information necessary to design an impressed current cathodic protection system for underground structures.

This chapter will discuss the various parameters which must be considered in the design of an impressed current cathodic protection system. These parameters include the following:

1. Protective current requirements
2. Anode bed resistance
3. Anode bed layout
4. Anode life expectancy
5. Rectifier sizing

REVIEW OF IMPRESSED CURRENT SYSTEM FUNDAMENTALS

Definition

Cathodic protection can be defined as the reduction or elimination of corrosion by making a metallic structure cathodic with respect to the electrolyte in which it is installed. This is accomplished by applying current to the structure by means of an impressed direct current or attachment of a galvanic anode to the structure.

Cathodic protection makes a metallic structure the cathode of a purposely designed electrochemical cell thereby protecting it from

corrosion. The protective current is either developed from within the cell or introduced to the cell from an external source which is large enough to overcome the effect of corrosion currents being discharged from the anodic areas of the structure. When the surface of the structure is fully polarized, corrosion of the structure is controlled. In a sense, the corrosion process is not eliminated but merely transferred to an expendable, or sacrificial, material (anode).

Theory of Operation

The impressed current cathodic protection system utilizes an external power source to provide a potential difference between the anode(s) and the protected structure. The anodes are connected to the positive terminal and the structure to the negative terminal of the power source. Current flows from the anodes through the electrolyte and onto the surface of the structure. It then flows along the structure and back to the power supply through an electrical conductor. Since the structure is picking up current from the electrolyte, the structure is protected. The protective current output of the power supply is adjusted to deliver sufficient current to overcome the corrosion currents trying to leave the anodic points on the structure. As the anodes discharge current they are consumed. Therefore it is desirable to use anode materials that are consumed at lower rates than magnesium, zinc, and aluminum which are used in sacrificial or galvanic systems. Special alloys and combination materials are used in impressed current systems to obtain a long, useful life expectancy from the system.

Application

The impressed current cathodic protection system, in most cases, utilizes a variable power source. Impressed current systems are capable of protecting large structures or structures which require greater magnitudes of current than can be provided economically by a galvanic anode system. These systems can be designed to protect bare (uncoated) structures, poorly coated, or well coated structures. As the amount of surface area to be protected increases, the total current requirement increases and impressed current systems become the system of choice.

Advantages and Disadvantages

Impressed current systems can be designed for a variety of applications with a reasonable degree of flexibility. This is a distinct advantage of this type of system, along with the ability to increase or decrease the current output, either automatically or manually, by changing the output voltage. The disadvantages of the system are the increased maintenance requirements, tendency for higher operating costs, and possibility of contributing to stray current interference on neighboring structures.

INFORMATION USEFUL FOR DESIGN OF AN IMPRESSED CURRENT CATHODIC PROTECTION SYSTEM

Before embarking on the design of a system, certain information should be gathered, analyzed, and factored into the design:

1. What is the pipe material? Is it steel (including grade of steel), cast iron, wrought iron or other material? What is the known electrical resistance?
2. Is the line bare or coated? If coated, what is the coating material and what coating specifications were used?
3. If it is an existing line, is there a leak record? If so, information on the location and date of occurrence of each leak will

positively indicate the more serious problem areas.

4. What is the pipe diameter, wall thickness and weight per foot? Is there any data on any changes in these items along the route of the line?
5. What are the location and construction details of all corrosion test points which have been installed along the line? If no test points have been installed for corrosion test purposes, determine locations where contact can be made with the pipeline for test purposes (other than by driving contact bars down to the pipe).
6. Is the line of all-welded construction or are mechanical couplers used?
7. What are the locations of branch taps?
8. What are the locations of purposely isolating flanges or couplers, if any, used to sectionalize the line or to isolate it electrically from other portions of the system or from piping of other ownership?
9. Obtain route maps and detail maps giving as much data as is available.
10. What are the locations of underground structures of other ownership that cross the pipeline to be surveyed? If any of these structures are cathodically protected, determine the location of cathodic protection current sources (particularly rectifiers) that may be in close proximity to the structure to be protected.
11. Location of possible sources of man-made stray current (such as DC electric transit systems or mining operations) that could affect the line under study.
12. Do any sections of the pipeline closely parallel (within 200 feet or so) high-voltage electric transmission lines? If so, what is the length of such exposure, how close is the pipeline to the towers, at what voltage

does the electric line operate, and what method is used for grounding the towers? (This information is significant because rectifier installations and isolating joints in well coated pipelines, closely parallel to high-voltage electric lines, may be damaged by induced AC voltage surges under electric system fault conditions if preventive measures are not taken.)

13. Is the line now operated at elevated temperatures, or will it be so operated in the foreseeable future? (High temperature could cause deterioration of coatings used and increase the current requirement to achieve corrosion control.)
14. Is AC power available to provide power to the rectifier?

DESIGN OF AN IMPRESSED CURRENT ANODE BED

General

There are several steps to be taken in designing an impressed current anode bed. The initial steps include:

- Selecting an anode bed site.
- Selecting an anode bed type.

Once the anode bed site and type have been selected, the designer can proceed to evaluate the different parameters required to complete the design of the selected impressed current anode bed.

Selecting an Anode Bed Site

The following factors should be taken into account when considering an anode bed site:

- a. **Soil Resistivity** - Soil resistivity is one of the most important factors to consider when selecting an anode bed site. Soil resistivity is one major component in evaluating the anode bed resistance. The anode bed resistance is a critical component in the

determination of protective current output and rectifier size. Usually, the lower the resistivity, the fewer number of anodes required to deliver a given current. In many cases, the area of lowest resistivity is considered a prime location for an anode bed site.

- b. **Soil Moisture** - Another factor to consider in the selection of an anode bed site is the soil moisture at the proposed anode depth. In most cases, soil resistivity decreases as the moisture increases until the soil becomes saturated. When possible, anodes should be installed below the water table (assuming the water resistivity is not too high), or in areas of high moisture content such as swamps, ditches, creek beds, etc.
- c. **Interference With Foreign Structures** - Structures such as pipelines, underground metallic sheathed electrical cables, or well casings, may be subjected to stray current interference problems. Therefore, anode beds should be located away from foreign structures whenever possible. Local utilities should be contacted to determine if underground structures exist in the area of the proposed anode bed location.
- d. **Power Supply Availability** - The selection of an anode bed site may be influenced by the availability of an economical source of power to be used to provide the required cathodic protection DC current.
- e. **Accessibility for Maintenance and Testing** - The anode bed site selected must be accessible to construction vehicles for anode bed installation, testing and repairs.
- f. **Vandalism** - Anode bed locations should be selected so as to minimize the potential for vandalism.
- g. **Purpose of Anode Bed and Site Availability** - Two additional factors that have to be considered in the process of selecting an anode bed site are the intended purpose of the anode bed and the possibility

of acquiring the required right-of-way for the installation. Is the intent of the anode bed to protect a long section of the pipeline (assuming the pipeline is well coated), or is it the intent to afford localized protection to a short section of a pipeline (poorly coated) or a structure? In the first case, the approach may be the installation of one remote type anode bed near the midpoint of the pipeline section, or perhaps the installation of a deep anode bed near the midpoint area. In the second case, the approach could be the installation of a distributed anode bed.

Once a determination has been made as to the intent and purpose of the installation and the most suitable type of installation, the land availability should be investigated.

Selecting Anode Bed Type Based on Site Selection

Prior to selecting the anode bed type, it is wise to consider the major types of anode beds used and application conditions associated with each.

Distributed Anode Bed

A distributed anode bed is used to protect a limited area of the pipeline. The anode bed is generally installed close to the structure and, hence, is sometimes called a “closely coupled anode bed”. Distributed anode beds are used to reduce potential interference effects on neighboring structures, to protect sections of bare or ineffectively coated pipelines, and pipelines in congested areas where electrical shielding might occur with other anode bed types.

A distributed anode bed can be made of multiple individual anodes connected to a header cable. A distributed anode bed can also be one long continuous anode. This is referred to as a “linear anode”.

Remote Anode Bed

A remote anode bed, sometimes called a

“conventional anode bed” or a “point-type” anode bed, consists of anodes installed in the earth at a distance away from the pipeline. This type of anode bed is normally used to distribute protective current over a broad area of the pipeline to be protected.

A remote anode bed used to protect a pipeline is usually installed perpendicular to the pipeline, and the first anode may be more than 100 feet away. The anodes are typically installed on 10 to 30 foot spacings.

Remote anode beds can also be installed parallel to or at an angle to the pipeline, depending on right-of-way availability. The main difference between a perpendicular and a parallel installation is that the gradient effect on the pipeline from a perpendicular anode bed would be less than from a parallel anode bed (assuming the line of parallel anodes is at a distance from the pipeline equal to that of the first anode in a perpendicular anode bed). Figure 5-1 is an example of a remote anode bed design with the anodes parallel to the lines to emphasize the anodic gradients around the anode bed and the cathodic gradients around the pipeline.

The term “remote”, as associated with this type of anode bed design, means that the pipeline is outside of the anodic gradient of the anode bed caused by the discharge of current from the anodes to the surrounding soil (referred to as “remote earth”). This would allow a better spread of the protective current to be achieved, thus protecting a larger section of a pipeline from one installation. In real life however, remote anode beds are installed at distances from a pipeline where the remaining gradient around the pipeline is normally small (not zero).

Deep Anode Bed

A deep anode bed utilizes anodes installed electrically remote from the structure in a vertical hole drilled to a minimum depth of 50 feet and, in some cases, as deep as 1,000 feet. This approach achieves similar results as a remote surface anode bed.

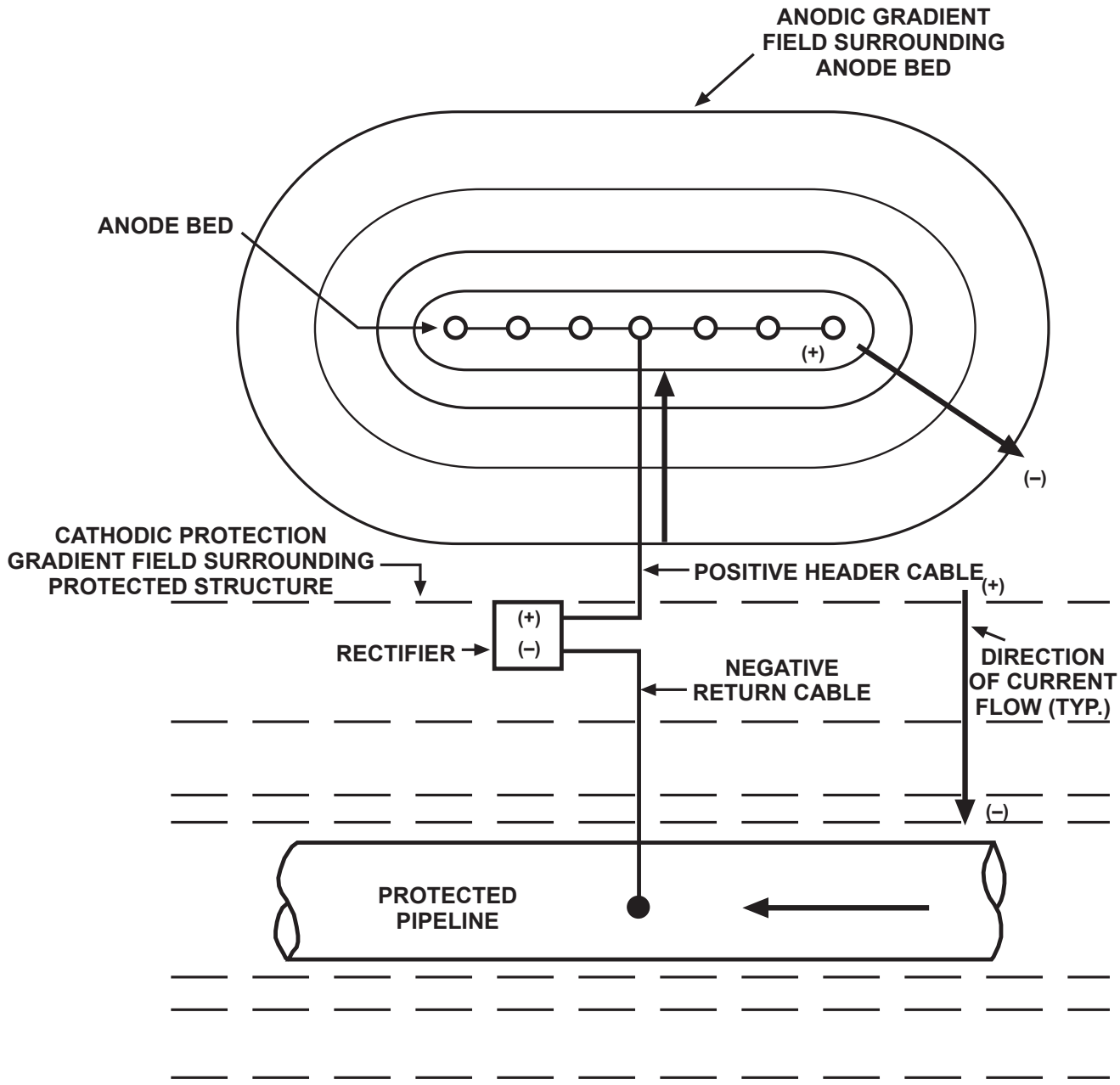

REMOTE ANODE BED OPERATION

FIGURE 5-1

Deep anode beds are usually effective when high surface soil resistivities exist over deeper low-resistivity areas where the anodes are installed.

Hybrid Anode Bed

In some cases, on complex structures, different anode bed types are used in combination to afford complete protection to the pipeline. An example may be the case where a remote anode bed has been used to protect several miles of a well coated pipeline, but shielding from foreign structures occurs in a localized area. In this case, a distributed anode bed might be considered to supplement the effectiveness of the remote anode bed. This combination of anode beds is sometimes referred to as a hybrid approach.

The designer may find himself involved in cases where site availability is scarce and where the type of anode bed to be selected is dependent on the sites available. A similar case would develop if the size of the site available is restricted. These conditions may develop in urban areas or in instances in which the land owner may not wish to sell or lease any land for the installation.

Land limitations may dictate that the installation has to be restricted to the existing right-of-way, in which case a distributed type anode bed may be selected for a localized condition or a deep anode installation may be selected for protection of extended areas.

In cases where the site availability may dictate the type of anode bed, it would be advisable to analyze further the soil conditions to be able to determine which is the most economical type of design that would do a proper job.

As previously mentioned, soil with a high resistivity layer near the surface and a low or lower resistivity layer underneath would be well suited for a deep anode type of installation. This type of soil condition can be encountered along a pipeline at areas where a relatively shallow (sometimes slightly more than pipeline

depth) surface soil overlies a high resistivity layer of rock which, in turn, overlies a layer of soil of relatively low resistivity. The current discharge from a deep anode bed in this type of soil arrangement could extend laterally for considerable distances and work its way up through the higher resistivity rock layer to the surface soil where the structure to be protected is installed.

In contrast with the above example, the case may be where the surface resistivity is low and the underlying soil is of high resistivity. In this case, a surface remote or distribution type of anode bed can be effectively utilized and a deep anode bed should not be considered.

In the cases where there are no restrictions to the type of anode bed to be utilized from any of the parameters listed in the preceding sections, economics would then be the deciding factor.

Tests Required for Anode Bed Design

The design of an impressed current anode bed is normally based on test data acquired in the field. The basic tests that should be conducted are soil resistivity and current requirement tests.

Soil resistivity tests are conducted along the route of the pipeline and at the locations selected for the anode bed installation.

Referring to the soil resistivity data shown in Table 5-1, let us assume that we are going to install a vertical anode bed to a depth of ten (10) feet. The weighted average soil resistivity to that depth (pin spacing) is shown as 19,533 ohm-cm. For design calculation purposes, an average resistivity of 20,000 ohm-cm should be used.

It should be noted again that the resistivity value used for design purposes should be obtained in the specific area where the anode bed will be installed, as there can be considerable variations in soil resistivity within short distances. An actual case example of this problem was an anode bed designed on the basis of soil resistivity data taken about 50 feet

TABLE 5-1**Typical Soil Resistivity Data**

Galvanometer Dial Reading	Multiplier Setting	Resistance (Ohms)	Spacing (ft)	Factor	Resistivity (Ohm-cm)
2.4	10	24	2.5	191.5	11,490
1.6	10	16	5	191.5	15,320
10.2	1	10.2	10	191.5	19,533
6.2	1	6.2	15	191.5	17,801
2.6	1	2.6	20	191.5	9,958
8.2	0.1	0.82	25	191.5	3,926

away from the foot of a hill. Because of right-of-way considerations, the anode bed was moved 30 feet towards the foot of the hill without new soil resistivity measurements. When the system was energized, the resistance of the anode bed was found to be about ten (10) times higher than it would have been at the location originally selected.

The second set of tests that should be conducted are current requirement tests to determine the amount of current required to achieve protection of a pipeline/structure or a section thereof. In the event that the structure or pipeline is proposed and not yet installed, the current requirement must be estimated by assuming a current density.

A temporary anode bed must first be set up, preferably at the location of the proposed anode bed installation. The temporary anode bed may consist of several ground rods driven into the ground and connected to a portable rectifier or other DC source. Soil resistivity test pins may also be used. Temporary power sources, such as batteries and DC welding machines, may also be used.

A creek or small lake, in close proximity to the structure requiring protection, can be used to set-up a temporary anode bed. Household grade aluminum foil unrolled into the water and connected to a DC power source using clip leads can provide an excellent temporary anode bed for use when conducting current requirement tests.

Current requirement tests are conducted by energizing the temporary anode bed and taking "ON" and "OFF" potential readings along the pipeline/structure using a high input resistance voltmeter and a portable copper-copper sulfate (Cu-CuSO₄) reference electrode. While taking potential readings, the current output of the temporary anode bed is increased until protection is achieved in the entire pipeline/structure, based on established cathodic protection criteria, as discussed in Chapter 1 of this course. Figure 5-2 shows a typical setup for current requirement tests.

At times, it may be difficult to obtain an output from the temporary anode bed that is large enough to achieve full protection of the entire pipeline/structure. Should this be the case, the actual current requirements can be calculated by extrapolating the data obtained to the desired protective levels.

As an example, let us consider a test setup in which the output of the temporary anode bed is 10 amperes, and the potential shifts obtained are:

Location	Vg-ON	Vg-OFF	ΔV
East End	-0.75 V	-0.45 V	-0.30 V
Midpoint	-0.95 V	-0.55 V	-0.40 V
West End	-0.71 V	-0.45 V	-0.26 V

From the above data it can be seen that the largest shift required to meet the -0.85 volt protective criterion is 400 millivolts, [0.45 (East or West End) - (-0.85)] and the lowest shift obtained with 10 amperes is 260 millivolts. The total current required can be calculated as follows:

$$I_T = I_A \times \frac{\Delta V_{REQ}}{\Delta V_g}$$

Where:

I_A = Applied Test Current

ΔV_{REQ} = Potential Shift Required to Meet -0.85 Protective Criterion

ΔV_g = Lowest Voltage Shift Obtained During Test

I_T = Total Current Required

$$I_T = 10 \times \frac{400}{260} = 15.385 \text{ Amperes}$$

A total of approximately 16 amperes would be required as a minimum to meet the -0.85 volt criterion.

It is important to note that the amount of current required to cathodically protect a pipeline or

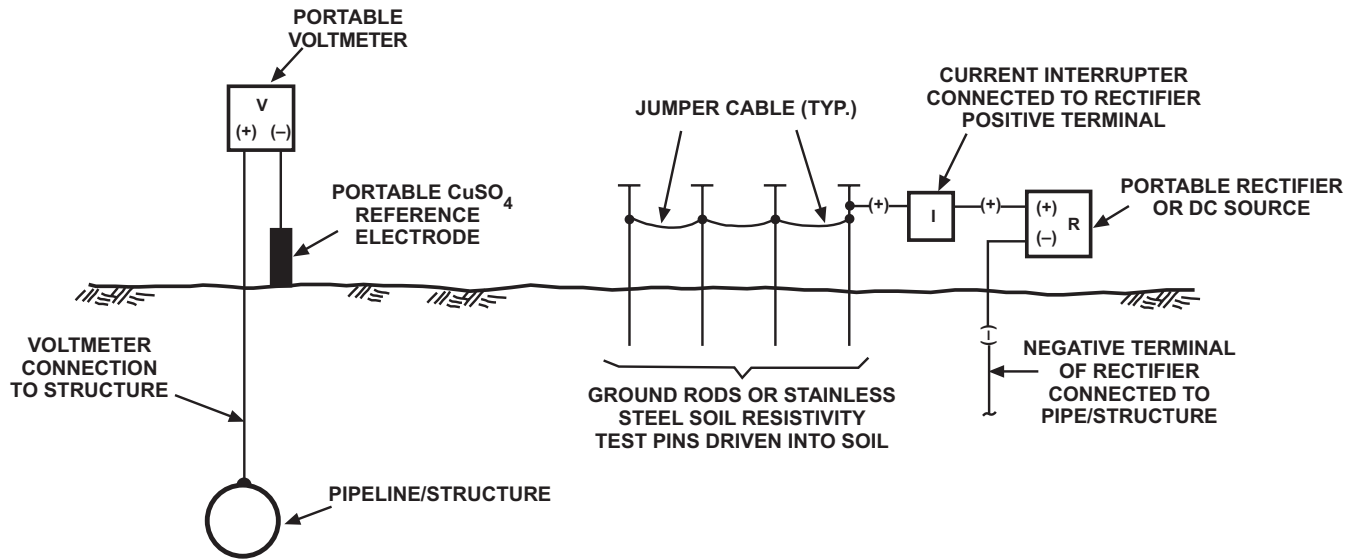

TYPICAL CURRENT REQUIREMENT TEST SET UP

FIGURE 5-2

structure is greatly affected by the condition of the coating on the structure. A bare structure may require many times the amount of current to protect the same pipeline/structure, if it were properly coated. Table 5-2 shows typical current requirements for a 5 mile section of 18-inch diameter steel pipe with various degrees of coating effectiveness.

DESIGN CALCULATIONS

The following examples show the various steps necessary to design a cathodic protection system for underground pipelines.

Existing Structures

For existing structures, the design can be based upon data obtained in the field through the previously mentioned current requirement testing to determine the actual current necessary to achieve cathodic protection.

Current Requirement

A temporary anode bed is set up using 5 ground rods and a portable rectifier. The ground rods are driven approximately 1½ feet into the ground at 10-foot spacing. The measured output of the rectifier is 34 volts and 0.40 amperes. While interrupting the rectifier output, the following pipe-to-soil potential readings were taken at various locations with respect to a portable copper-copper sulfate (CuCuSO₄) reference electrode, placed directly over the pipeline in the area under the influence of the temporary anode bed, and the change in potential (ΔV) was calculated.

PIPE-TO-SOIL POTENTIAL (Volts)			
Location	On	Off	ΔV
1	-0.592	-0.561	-0.031
2	-0.570	-0.523	-0.047
3	-0.603	-0.545	-0.058
4	-0.598	-0.527	-0.071
5	-0.693	-0.575	-0.118

6	-0.833	-0.635	-0.198
7	-0.865	-0.650	-0.215
8	-0.814	-0.611	-0.203
9	-0.731	-0.605	-0.126
10	-0.655	-0.590	-0.065
11	-0.630	-0.575	-0.055
12	-0.640	-0.580	-0.060

Step No. 1

Using the lowest change in potential shift (ΔV) measured during the tests, calculate the voltage shift required to satisfy the -0.85 volt cathodic protection criterion.

Lowest Potential Shift = -0.031 Volts
Obtained at Location No.1 (based on data in table)

Off Potential = -0.561

Required Voltage Shift =
-0.850 - (-0.561) = -0.289 Volts

Step No. 2

Using the previously calculated values, calculate the required current using the following relation:

$$\frac{\Delta V_g}{\Delta V_{REQ}} = \frac{I_A}{I_T} \quad \text{or} \quad I_T = I_d \times A_s$$

Substituting the Values:

$$\frac{-0.031}{-0.289} = \frac{0.40}{I_T} \quad \therefore I_T = 3.73 \text{ amperes}$$

Step No. 3

Verify that, with an output of 3.73 amperes, a potential of -0.85 volts can be achieved at the point of lowest "OFF" potential obtained during the test.

TABLE 5-2

Typical Current Requirements Based On Coating System Effective Resistance

Effective Coating Resistance ⁽¹⁾ (ohm-ft²)	Current Requirement (Ampere)
Bare Pipe ⁽²⁾	187.50
10,000	3.73
25,000	1.49
50,000	0.75
100,000	0.37
500,000	0.075
1,000,000	0.0373
5,000,000	0.007
“Perfect Coating”	0.000015

- (1) Effective coating resistance, as defined in the above table, of 10,000 to 25,000 ohm-ft² indicates poor application or handling during installation. Resistance of 100,000 to 5,000,000 ohm-ft² indicates good to excellent application. Installation in 1,000 ohm-cm soil.
- (2) Bare pipe in this table is assumed to require a minimum of 1.5 milliamperes per sq. ft. of pipe surface. In practice, most design engineers use 2 milliamperes per sq. ft. for pipe-in-soil, unless the environment is acidic, contains high concentrations of chlorides, bacteria, or the pipe is operating at elevated temperatures. In these cases, as much as 3.5 to 5.0 milliamperes per sq. ft. may be required.

Lowest "OFF" Potential = -0.523 Volts at Location No.2

Potential Shift (ΔV) at That Location During Test = -0.047 Volts

Potential Shift Required = -0.850 - (-0.523) = 0.327 Volts

Total Current Required can be calculated as follows:

$$\frac{\Delta V_g}{\Delta V_{REQ}} = \frac{I_A}{I_{T1}} \quad \text{or}$$

$$\frac{\text{Lowest Voltage Shift}}{\text{Required Voltage Shift}} = \frac{\text{Applied Current Used}}{\text{Current Required (I}_{T1}\text{)}}$$

Substituting the Values:

$$\frac{-0.047}{-0.327} = \frac{0.40}{I_T} \quad \therefore \quad I_T = 2.783 \text{ amperes}$$

Step No. 4

The current required for achieving -0.850 volts throughout the tested section of the pipe is 3.73 amperes.

There are several points that the designer should bear in mind when interpreting the results of current requirement tests:

1. The results indicate current requirement only in the area where the temporary anode bed was installed, and where the pipe-to-soil data indicated an influence from the anode bed.
2. If two or more anode beds are going to be installed for protection of an electrically continuous pipeline/structure, the effects of the anode beds are additive. Therefore, if at a point of the pipeline, 1 anode bed with 1 ampere output achieves half of the required shift, and a second anode bed with 1 ampere output at a different location also achieves half of the required shift at the same location, the total current required is 2

amperes and not 2 amperes per anode bed.

3. The tests do not take into account future changes which might necessitate more current, such as additional deterioration of the coating.

In cases where the pipeline/structure has not been installed, or when current requirement tests are not feasible, current requirements can be estimated by selecting a current density and applying that current density to the pipeline surface area.

There are many different tables that have been published outlining current density requirements. One such table is shown as Table 5-3, and was taken from the NACE CORROSION ENGINEER'S REFERENCE BOOK.

As an example, if a proposed pipeline were to be coated and buried in relatively neutral (not alkaline nor acidic) but corrosive soil (due to non-homogeneous conditions), one might select 2 ma/ft² as the appropriate current density to establish the total current requirement. If the pipeline was anticipated to have a 95% coating efficiency, then 2 mA would be applied to the 5% of the pipeline that was bare.

EXAMPLE:

A 24-inch diameter pipeline two miles in length is being installed with a 95% efficient coating. Determine the total current required to achieve cathodic protection.

Step No. 1

Calculate the area to be protected using the following formula:

$$A_S = \pi \cdot d \cdot L \cdot 0.05$$

Where:

$$A_S = \text{Total Surface Area (ft}^2\text{)}$$

TABLE 5-3

Approximate Current Requirements for Cathodic Protection of Steel

Environment	mA/ft²
Sea Water - Cook Inlet	35 - 40
- North Sea	8 - 15
- Persian Gulf	7 - 10
- US - West Coast	7 - 8
- Gulf of Mexico	5 - 6
- Indonesia	5 - 6
Bare Steel in Soil	1 - 3
Poorly Coated Steel in Soil or Water	0.1
Well Coated Steel in Soil or Water	0.003
Very Well Coated Steel in Soil or Water	0.003 or less

d = Pipeline Diameter (ft)
 L = Length of Pipeline (ft)
 .05 = 5% of Pipe Requiring Protection
 (Bare Area)

$$\pi = 3.1415$$

$$A_s = \pi \cdot 2 \cdot 5280 \cdot 2 \cdot 0.05$$

$$A_s = 3317.5 \text{ ft}^2$$

Step No. 2

Calculate the current required based on a 2 ma/ft² current density as follows:

$$I_T = I_d \times A_s$$

Where:

I_T = Total Current Required (Amperes)

I_d = Current Density (mA/ft²)

A_s = Total Surface Area (ft²)

$$I_T = (.002)(3317.5)$$

$$I_T = 6.64 \text{ Amperes}$$

Regardless of the method that is used to determine the current required to achieve protection, it is wise to consider increasing that value in the design stage for future requirements over the life of the system. This increase may be necessitated by coating degradation or additions to the structure. Most designers add 20% to cover these requirements.

Determining the Number of Anodes

After obtaining all the field data required for the design of the anode bed, the next step is the selection of the type of anode to be used and the calculation of the number of anodes required. The factors to be considered when calculating the number of anodes are:

1. Anode Material
2. Rate of Consumption of Anode

3. Current Required for Protection
4. Shape and Size of Anode
5. Maximum Anode Material Density
6. Life Expectancy

Of the above items, Nos. 1, 2, 4, and 5 are interdependent. The consumption rate and maximum allowable density depend on the anode material as do the shape and size of the anodes.

The first step in this phase of the design should, in most instances, be the selection of the anode material. Items to be considered for this selection are environmental conditions, consumption rate, and sizes available.

Although not a general problem with most underground structures, there could be instances where the anode material could be subjected to acidic or alkaline soil environments which could be detrimental to the anode material. Under these conditions, it would be wise to check with the anode manufacturers to insure that the actual environment will not adversely affect the anode material. Another environmental factor that could affect the material selection is whether the anodes will be installed in soil or water, or a combination of both.

As mentioned in Chapter 3 of this course, there are many different anode materials that could be used for impressed current systems. Even scrap steel has been used for anode material. Scrap steel, however, has a high consumption rate (approximately 20 lbs/amp-year). The most commonly used anode materials for conventional anode bed installations are graphite and high-silicon chromium-bearing cast iron anodes. Normal operating densities range between 0.2 and 1.0 amp/ft² for graphite with an average rate of consumption of 2.0 lb/amp-year, and between 0.5 and 2.5 amp/ft² for the high-silicon chromium-bearing cast iron anode with an average consumption rate of 0.75 lb/amp-year. These consumption rates are markedly reduced if the anode is installed in

coke breeze backfill. Other anode materials that have been used for soil installations in recent years are the platinized, mixed metal oxide and magnetite anodes.

The next step in the selection of the anode is to determine the sizes and shapes available. For soil installations, the 5-foot long anodes are normally used, and they are available in diameters ranging from 1½" to 4" (graphite and high-silicon iron only). The selection of the anode size will depend on the desired anode output and the required life expectancy.

Another variable to consider is the use of prepackaged canister anodes. These anodes consist of graphite, high-silicon chromium-bearing cast iron or other suitable anodes encased in a steel stove pipe filled with a select backfill. As discussed in Chapter 3, "Anode Materials", there are advantages and disadvantages to the use of canister anodes.

Now that we have selected the anode material and the type and size of the anode, we can proceed with calculating the number of anodes required.

EXAMPLE:

The current required to protect a pipeline, based on current requirement tests, is 15 amps including spare capacity for future demand. High-silicon chromium-bearing cast iron anodes (2" x 60") are to be used in the anode bed design. Required anode bed life expectancy is 20 years.

Step No. 1

Calculate the number of anodes required based on a consumption rate of 0.75 pounds per amp-year and a utilization factor (amount of anode material that can be lost to consumption before anode replacement is required) of 60%, and an anode weight of 60 lbs., using the following life expectancy formula:

$$\text{Desired Life} = \frac{\text{Weight} \times \text{Utilization Factor}}{\text{Req'd Current Output} \times \text{Consumption Rate}}$$

or

$$\text{Weight} = \frac{\text{Consumption Rate} \times \text{Desired Life} \times \text{Req'd Current}}{\text{Utilization Factor}}$$

$$= \frac{0.75 \times 20 \times 15}{0.60} = 375 \text{ lbs.}$$

$$\text{Number of Anodes} = \frac{375}{60} = 6.25 = 7 \text{ anodes}$$

Step No. 2

Calculate the number of anodes required based on a nominal current discharge per anode of 2.5 amps per anode (recommended output by manufacturer). Since the surface area of these anodes is 2.8 ft², the anodes would be operating at a current discharge density of approximately 0.9 amp/ft². This value falls within the range of 0.5 to 2.5 amp/ft² mentioned earlier in this chapter as the output range for this type of anode.

$$\begin{aligned} \text{Number of Anodes} &= \frac{\text{Required Current}}{\text{Max. Output per Anode}} \\ &= \frac{15}{2.5} = 6 \text{ anodes} \end{aligned}$$

Based on the above calculations in Step 1, the number of anodes required is 7.

An alternative approach to the method outlined above for the determination of the number of anodes required for a conventional anode bed is the "cut and try" method. With this method, an actual anode installation is made and tests are conducted to ascertain the degree of protection achieved. The number of anodes is increased until the desired level of protection is reached. Calculations should then be made to determine if the life expectancy would be met with this method. The size of the rectifier can be determined from the actual field tests.

Calculating the Anode Resistance-to-Earth

The next step in the design process is the calculation of the resistance-to-earth of the anodes. There are exceptions to this approach, such as in those cases in which the utility or the company has established a preferred range of anode bed resistance. If this is the case, then the preferred anode bed resistance becomes the primary factor in calculating the number of anodes required for the installation.

There are two basic approaches to calculating the resistance of an anode bed:

1. By using existing formulas, and
2. By using existing charts.

The anode bed resistance-to-earth can be calculated using one of the following formulas, as applicable, for the anode bed design:

Single Vertical Anode (H. B. Dwight formula)

$$R_v = \frac{0.00521 \cdot \rho}{L} \cdot \left(\ln \frac{8 \cdot L}{d} - 1 \right)$$

Where:

- R_v = Resistance-to-earth of single vertical anode in ohms
 ρ = Effective soil resistivity in ohm-cm
 L = Anode length in feet
 d = Anode diameter in feet

Multiple Vertical Anodes in Parallel (Erling D. Sunde Formula)

$$R_v = \frac{0.00521 \cdot \rho}{N \cdot L} \cdot \left(\ln \frac{8 \cdot L}{d} - 1 + \frac{2 \cdot L}{S} \cdot \ln 0.656 \cdot N \right)$$

Where:

- R_v = Resistance-to-earth, in ohms, of the vertical anodes connected in parallel
 ρ = Effective soil resistivity in ohm-cm
 L = Anode length in feet

- N = Number of vertical anodes in parallel
 d = Anode diameter in feet
 S = Spacing between anodes in feet

Single Horizontal Anode (H. B. Dwight formula)

$$R_H = \frac{0.00521 \cdot \rho}{L} \cdot \left(\ln \frac{4L^2 + 4L\sqrt{S^2 + L^2}}{dS} + \frac{S}{L} - \frac{\sqrt{S^2 + L^2}}{L} - 1 \right)$$

Where:

- R_H = Resistance-to-earth, in ohms, of the horizontal anode
 ρ = Effective soil resistivity in ohm-cm
 L = Horizontal anode length in feet
 N = Number of vertical anodes in parallel
 d = Anode diameter in feet
 S = Twice anode depth in feet

NOTE: When using prepackaged anodes or anode backfills (such as coke breeze), the dimensions of the canister or the backfill column must be substituted in the above formulas for the anode dimensions.

Using the anode bed/anode resistance-to-earth formulas listed above can be somewhat complicated and time consuming. Therefore, graphs have been developed such as the ones shown in Figures 5-3 and 5-4 to expedite the process of determining anode bed/anode resistance-to-earth.

Figure 5-5 shows a typical vertical anode design chart for an impressed current anode bed. The chart was developed on 2" x 60" anodes in an 8" x 7' column of 50 ohm-cm coke breeze backfill. The chart is based on anodes installed vertically in a straight line.

EXAMPLE:

The following example shows how both the formulas and the graphs can be used to determine the anode bed resistance-to-earth.

A conventional anode bed consisting of twenty-

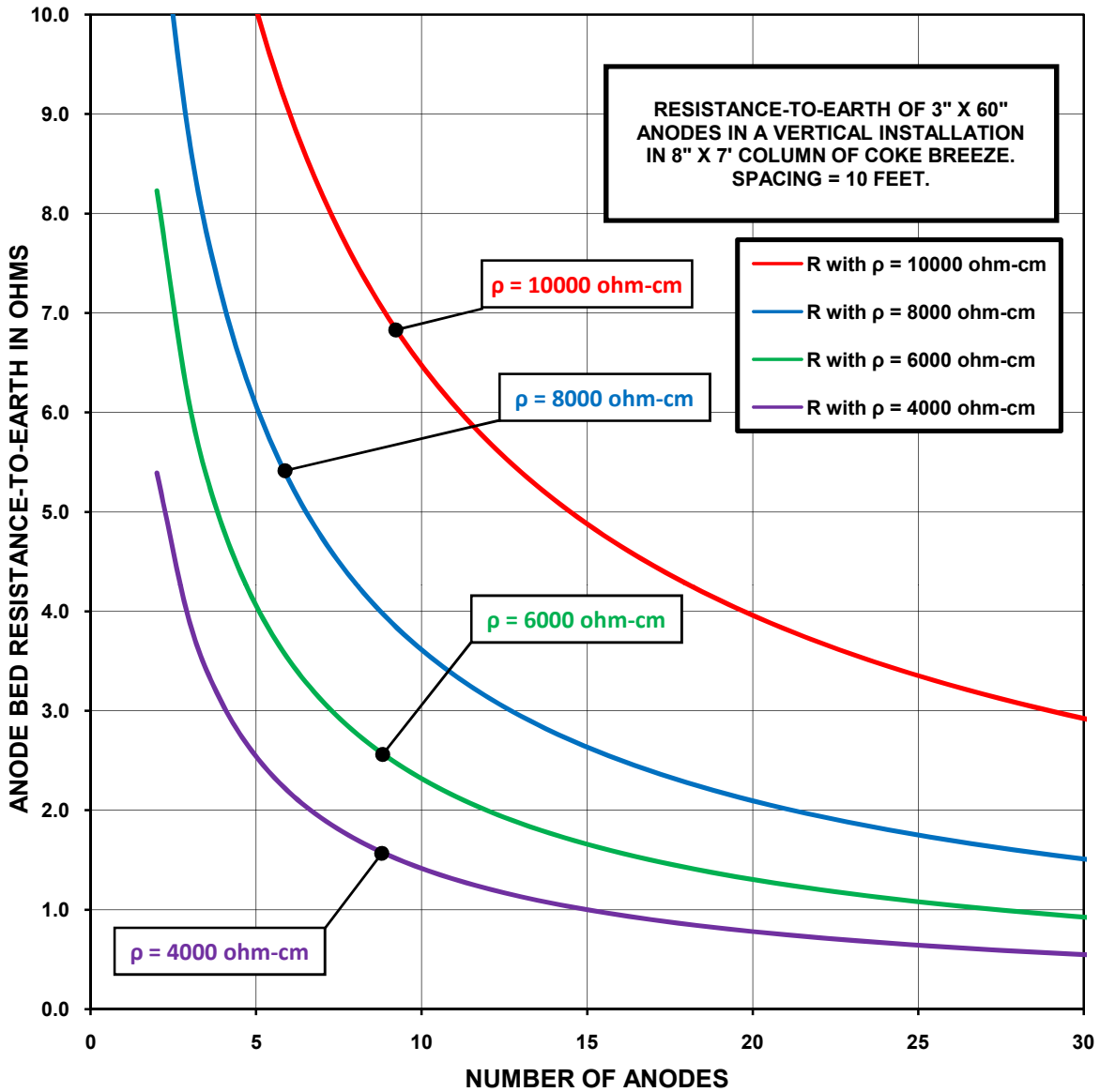

ANODE BED RESISTANCE-TO-EARTH OF 8" x 7' ANODES AT 10 FT SPACING AT VARIOUS SOIL RESISTIVITY VALUES

FIGURE 5-3

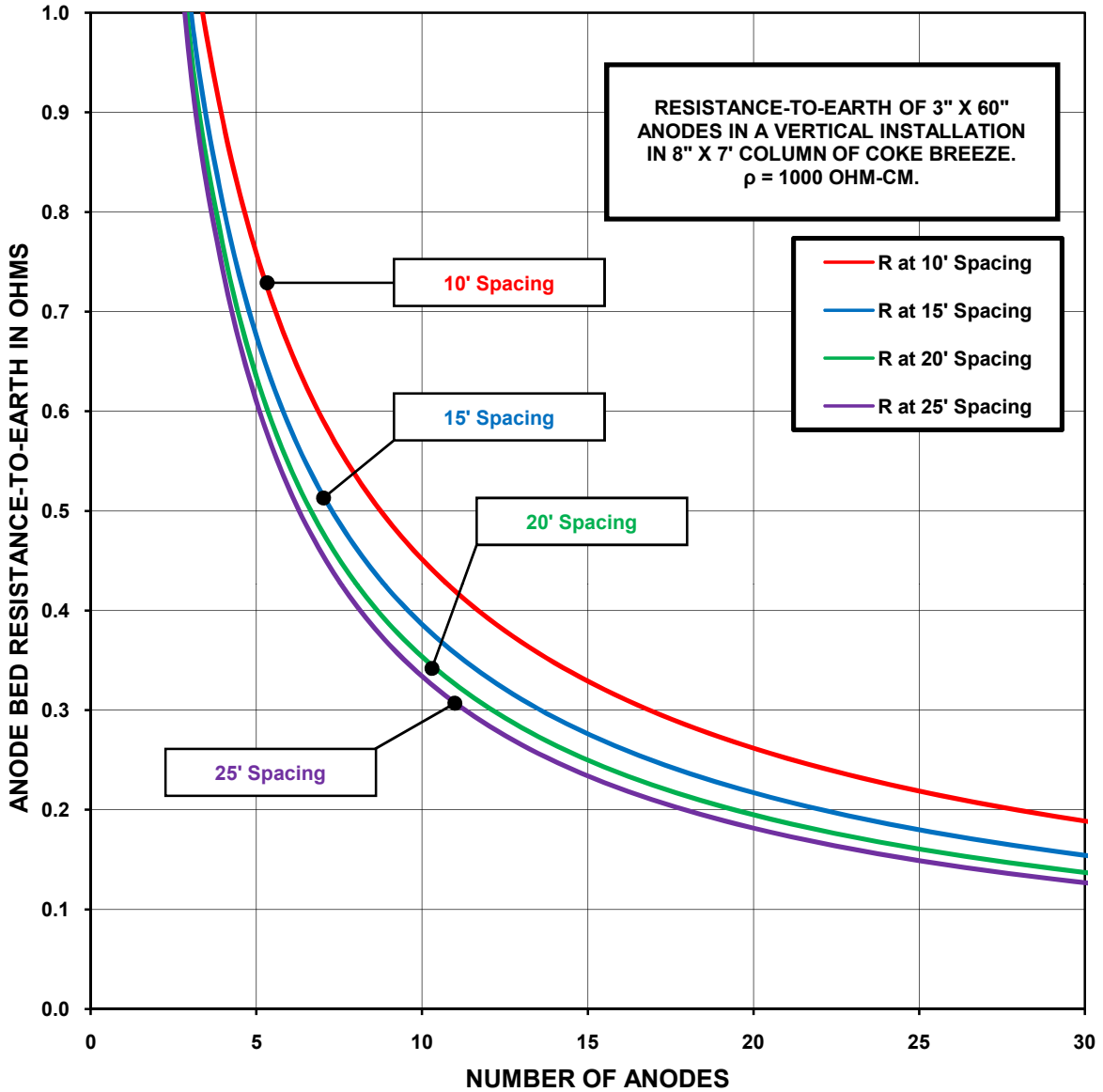

ANODE BED RESISTANCE-TO-EARTH OF 8" x 7' ANODES IN 1000 OHM-CM SOIL AT VARIOUS SPACINGS

FIGURE 5-4

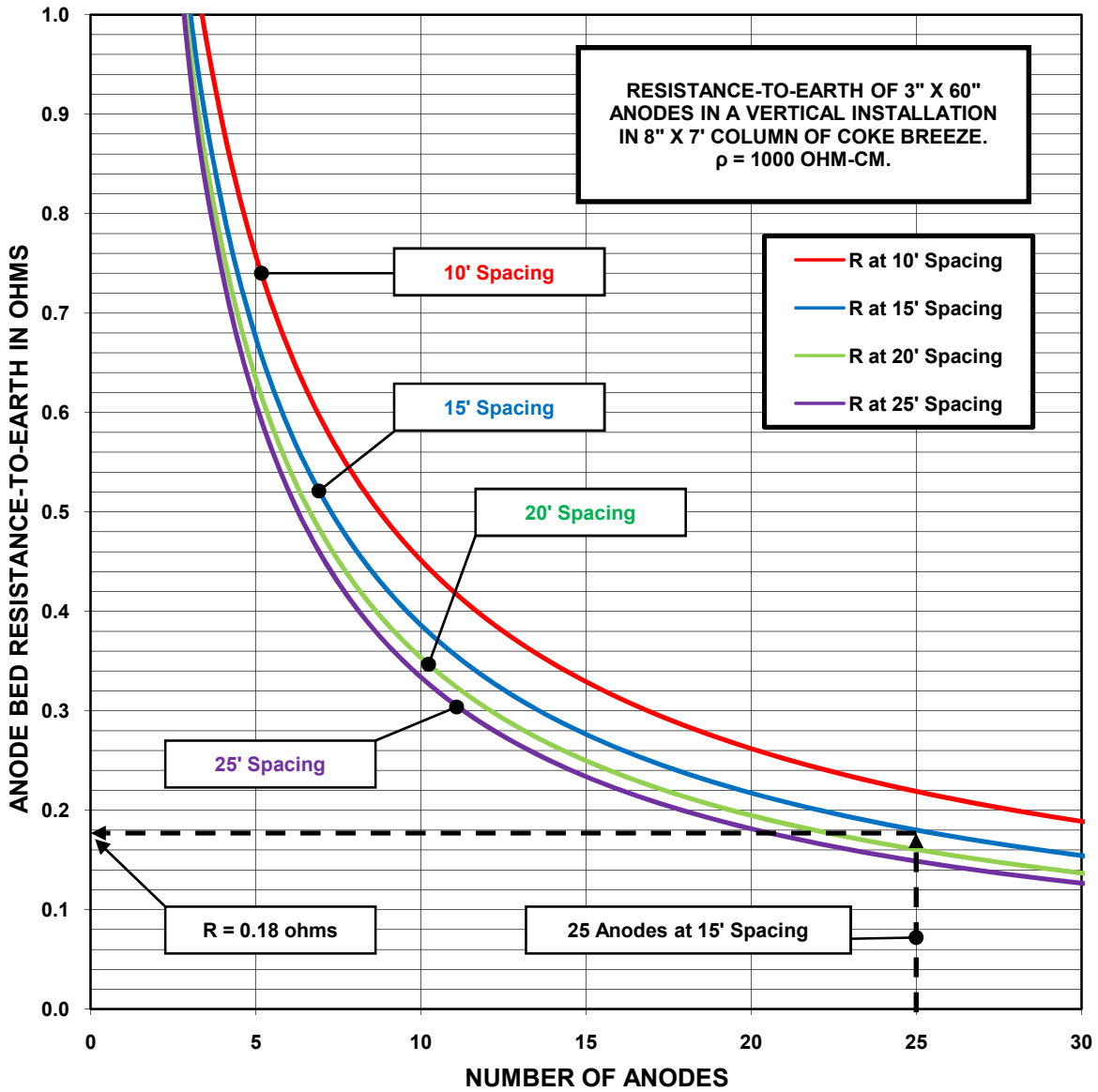

USING A GRAPH TO DETERMINE ANODE BED RESISTANCE-TO-EARTH

FIGURE 5-5

five (25) 2" x 60" anodes is to be installed in an 8" x 7' column of 50 ohm-cm coke breeze. Anodes are connected in parallel at 15' spacings. Soil resistivity is 10,000 ohm-cm.

Method No. 1 -- Using Sunde's formula to calculate the anode bed resistance-to-earth:

$$R_v = \frac{0.00521 \cdot \rho}{N \cdot L} \cdot \left(\ln \frac{8 \cdot L}{d} - 1 + \frac{2 \cdot L}{S} \cdot \ln 0.656 \cdot N \right)$$

Substituting the values in the above formula:

$$R_v = \frac{0.00521 \cdot 10000}{25 \cdot 7} \cdot \left(\ln \frac{8 \cdot 7}{0.667} - 1 + \frac{2 \cdot 7}{15} \cdot \ln 0.656 \cdot 25 \right)$$

After making all the calculations, the result is:

$$R_v = 1.8 \text{ ohms}$$

Method No. 2 -- Using the graph in Figure 5-5 to determine the anode bed resistance-to-earth:

Step No. 1:

Locate the number of anodes on the horizontal axis of the graph (25) and draw a vertical line up to the curve representing anodes at 15' spacing.

Step No. 2:

Draw a horizontal line from that point on the curve to the vertical axis of the graph and read the resistance which, in this case, is 0.18 ohm in 1,000 ohm-cm soil.

Step No. 3:

The resistance is directly proportional to the resistivity of the soil. Therefore, the resistance in 10,000 ohm-cm soil would be:

$$R_v = \frac{10000}{1000} \cdot 0.18 = 1.8 \text{ ohms}$$

Calculating Total Circuit Resistance

The total circuit resistance includes the following:

- Resistance-to-earth of the pipeline or structure
- Resistance of the CP system cables
- Resistance-to-earth of the anodes (anode bed resistance)

The resistance-to-earth of the pipeline/structure may be significant or negligible, depending on length of pipe and soil resistivity. Using the values on Table 5-2 and assuming, for example, that the current requirements listed are necessary to shift the pipe-to-soil potential approximately 0.40 volt, then, applying Ohm's Law, the resistance-to-earth values for those conditions range from 0.0021 ohm (0.40/187.5 - negligible) to 57.14 ohms (0.40/0.007 - very significant). The mid-range current requirement (0.37 ampere) represents a resistance-to-earth value of 1.081 ohms (0.40/0.37) which might be a significant percentage of the total circuit resistance.

The last factor to calculate for the circuit resistance is the resistance of the positive and negative cables. The first step would be to select the proper size of the cable. The cable size should be appropriate to carry the output current and to minimize the IR drop in the cable due to the current flow. Once the size of the cable is determined, the total length of cable to be used is multiplied by the per-foot resistance of the cable selected.

The next step is to calculate the total circuit resistance using the following formula:

$$R_T = R_{ABed} + R_C + R_S$$

Where:

R_T = Total circuit resistance

R_{ABed} = Anode bed resistance (using dimensions of carbonaceous backfill column for calculations)

R_C = Cable resistance
 R_S = Pipeline/structure-to-earth resistance

EXAMPLE:

Calculate the total circuit resistance of the conventional anode bed shown in Figure 5-6, using ten (10) 2" x 60" graphite anodes in 8" x 7' columns of 50 ohm-cm coke breeze backfill. Soil resistivity is 8,000 ohm-cm. Current required for protection is 15 amperes. The pipe to be protected is 3-mile long, 16-diameter carbon steel pipe. Assume a coating resistance of 500,000 ohm-ft².

Step No. 1

Calculate R_{ABed} :

$$R_{ABed} = \frac{0.00521 \cdot \rho}{N \cdot L} \cdot \left(\ln \frac{8 \cdot L}{d} - 1 + \frac{2 \cdot L}{S} \cdot \ln 0.656 \cdot N \right)$$

$R_{ABed} = 3.08$ ohms

Step No. 2

Calculate R_C , based on the effective system cable length and the resistance of the cable per linear foot. The effective cable length of the system (referring to Figure 5-6) can be determined using the following formula:

$$L_{cable} = L_{neg} + L_{pos1} + \frac{1}{2} L_{pos2}$$

Where:

- L_{cable} = Effective cable length (ft)
- L_{neg} = Negative return cable length (ft)
- L_{pos1} = Length of positive cable to first anode (ft)
- L_{pos2} = Length of positive cable between first and last anodes (ft)

$L_{cable} = 300 + 16 + 135/2 = 383.5$ ft

The cable resistance (R_C) can be calculated using the following formula:

$$R_C = R_{cable} \times L_{cable}$$

Where:

R_{cable} = Resistance per linear foot of cable based on a standard cable resistance table such as the one shown in Table 5-4. In this example, No.4 AWG cable is being used with a resistance of 0.2540 ohm per 1,000 ft.

$R_C = 383.5 \times 0.2540/1000$

$R_C = 0.0974$ ohm

Step No. 3

Calculate R_S for the 3 miles of coated 16-inch diameter carbon steel pipe, assuming a coating resistance of 500,000 ohm-ft².

$$R_S = R/A$$

Where:

- R = Coating resistance (ohm-ft²) = 500,000 ohm-ft²
- A = Surface area of pipe (ft²) = 66,350 ft²
- $R_S = 500,000/66,350 = 7.53$ ohms

Step No. 4

Calculate R_T :

$$R_T = R_{Gbed} + R_C + R_S$$

$$R_T = 3.08 + 0.0974 + 7.53$$

$$R_T = 10.71$$
 ohms

Sizing the Rectifier or DC Power Supply

The final step in designing a conventional anode bed system is sizing the DC output of the power supply to be used. The following factors must have been determined in order to size the DC output of the power supply.

1. **Total Circuit Resistance.** As indicated in

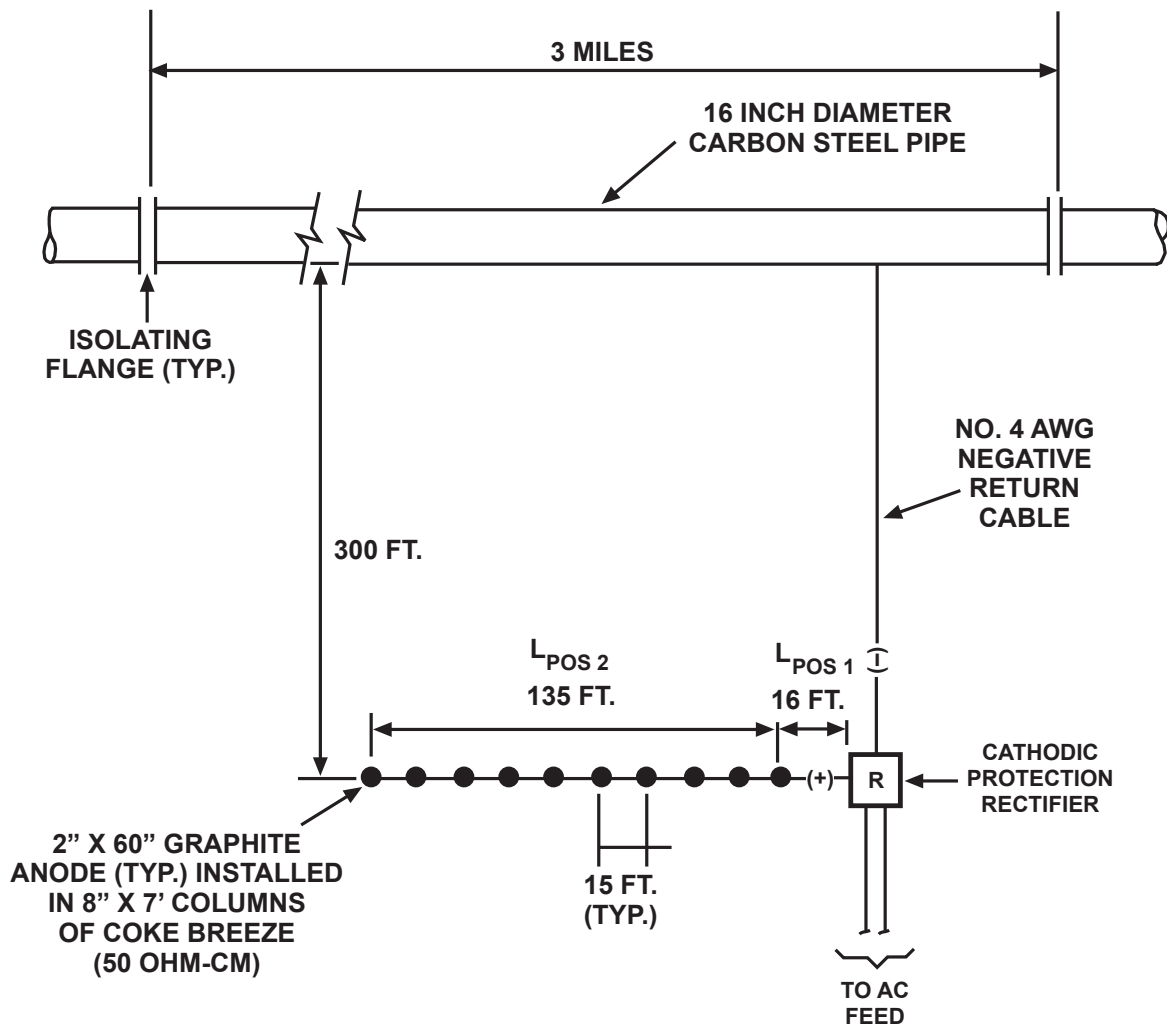

TYPICAL REMOTE ANODE BED DESIGN

FIGURE 5-6

TABLE 5-4**Concentric Stranded Single Conductor Copper Cable Parameters**

Size AWG	Overall Diameter Not Including Insulation (Inches)	Maximum DC Resistance @ 20° C (Ohms/1000 ft)	Maximum Allowable DC Current Capacity (Amperes)
14	0.0726	2.5800	15
12	0.0915	1.6200	20
10	0.1160	1.0200	30
8	0.1460	0.6400	45
6	0.1840	0.4030	65
4	0.2320	0.2540	85
3	0.2600	0.2010	100
2	0.2920	0.1590	115
1	0.3320	0.1260	130
1/0	0.3730	0.1000	150
2/0	0.4190	0.0795	175
3/0	0.4700	0.0631	200
4/0	0.5280	0.0500	230
250 MCM	0.5750	0.0423	255

the previous section, the total circuit resistance consists of the anode bed-to-soil resistance, the cable resistance and the pipeline (structure)-to-earth resistance.

2. **Total Current Required.** The total current required to protect the pipeline/structure based on current requirement tests. As mentioned earlier, the test results are normally increased by 20% or more to provide for future requirement increases.
3. **Back Voltage.** The back voltage is the voltage that exists in opposition to the applied voltage between the anodes and the protected structure. Anode bed anodes with carbonaceous backfill will usually have a back voltage of about 2 volts. In areas of unusual soil composition, the back voltage may be slightly higher, but, for design purposes, 2 volts should be used unless experience in a specific area dictates otherwise.

Using these three factors, the minimum DC output of the power supply can be determined/calculated. The required current output of the power supply is equal to the total current required plus a percentage for later deterioration. The DC output voltage can be calculated using the following formula:

$$V_0 = I_R \times R_T + V_b$$

Where:

V_0 = Required Power Supply Voltage

I_R = Total Current Required

R_T = Total Circuit Resistance

V_b = Back Voltage

EXAMPLE:

Assume the pipeline in the previous example has a current requirement of 0.003 mA/ft² and calculate the required power supply voltage

Step No. 1

Calculate total current required, plus 20% for

deterioration.

$$I_R = \text{Surface Area of Pipe} \times \text{Current Density}$$

$$I_R = 66,350 \text{ ft}^2 \times 0.003 \text{ mA/ft}^2$$

$$I_R = 0.199 \text{ Amp}$$

With 20% spare capacity $I_R = 0.239 \text{ Amp}$.

Step No. 2

Calculate required power supply voltage using R_T from previous example.

$$V_0 = I_R \times R_T + V_b$$

$$V_0 = (0.239 \times 10.71) + 2$$

$$V_0 = 4.56 \text{ Volts}$$

The required output rating as calculated is not what would be considered a standard off-the-shelf rating. The actual rating of the rectifier unit purchased should be based, whenever possible, on standard available ratings. In this case, the closest rating might be 4 amps and 8 volts.

DESIGN OF DISTRIBUTED ANODE BED

The distributed anode bed is installed in close proximity to the pipeline/structure to be protected. Distributed anode beds are used primarily when it is desired to protect a limited area of a pipeline, or to protect sections of a bare or coated pipeline in areas where electrical shielding precludes effective protection with remote anode bed installations. Figure 5-7 shows a typical distributed anode cathodic protection system.

Many companies designed this type of anode bed using a combination of the current pickup by the structure and the gradient established in the soil by the anodes. The current pickup makes the potential of the pipeline/structure swing in the negative direction, while the anode gradient makes the soil surrounding the pipeline/structure swing in the positive direction. The result is an additive effect.

Figure 5-8 shows how one anode swings the

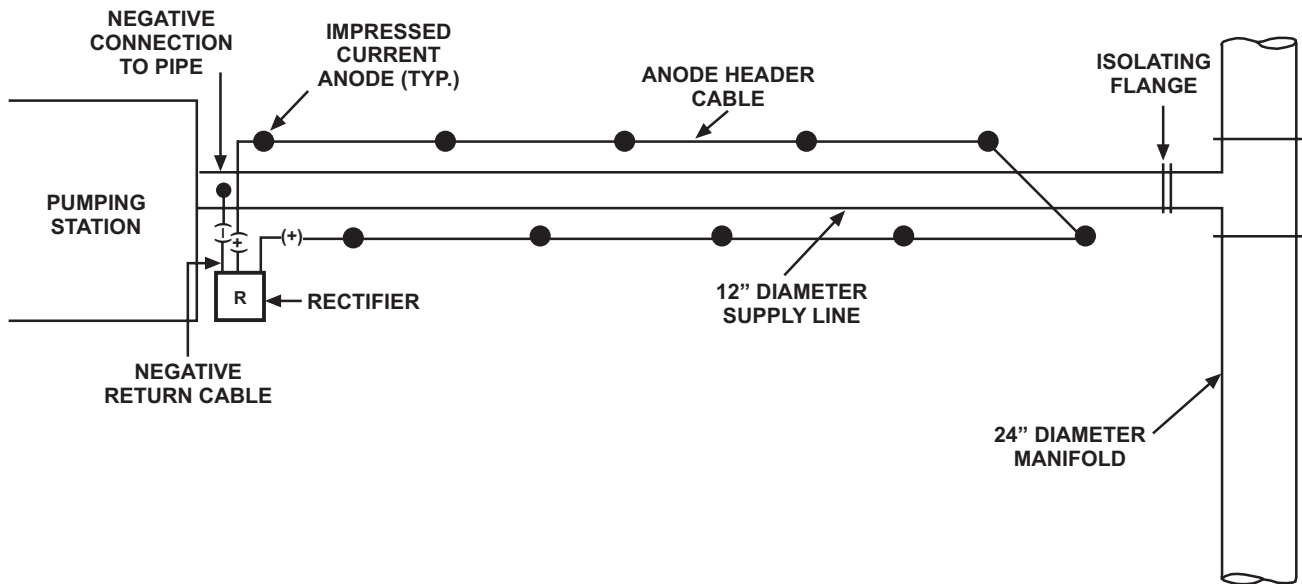

TYPICAL DISTRIBUTED IMPRESSED CURRENT ANODE SYSTEM

FIGURE 5-7

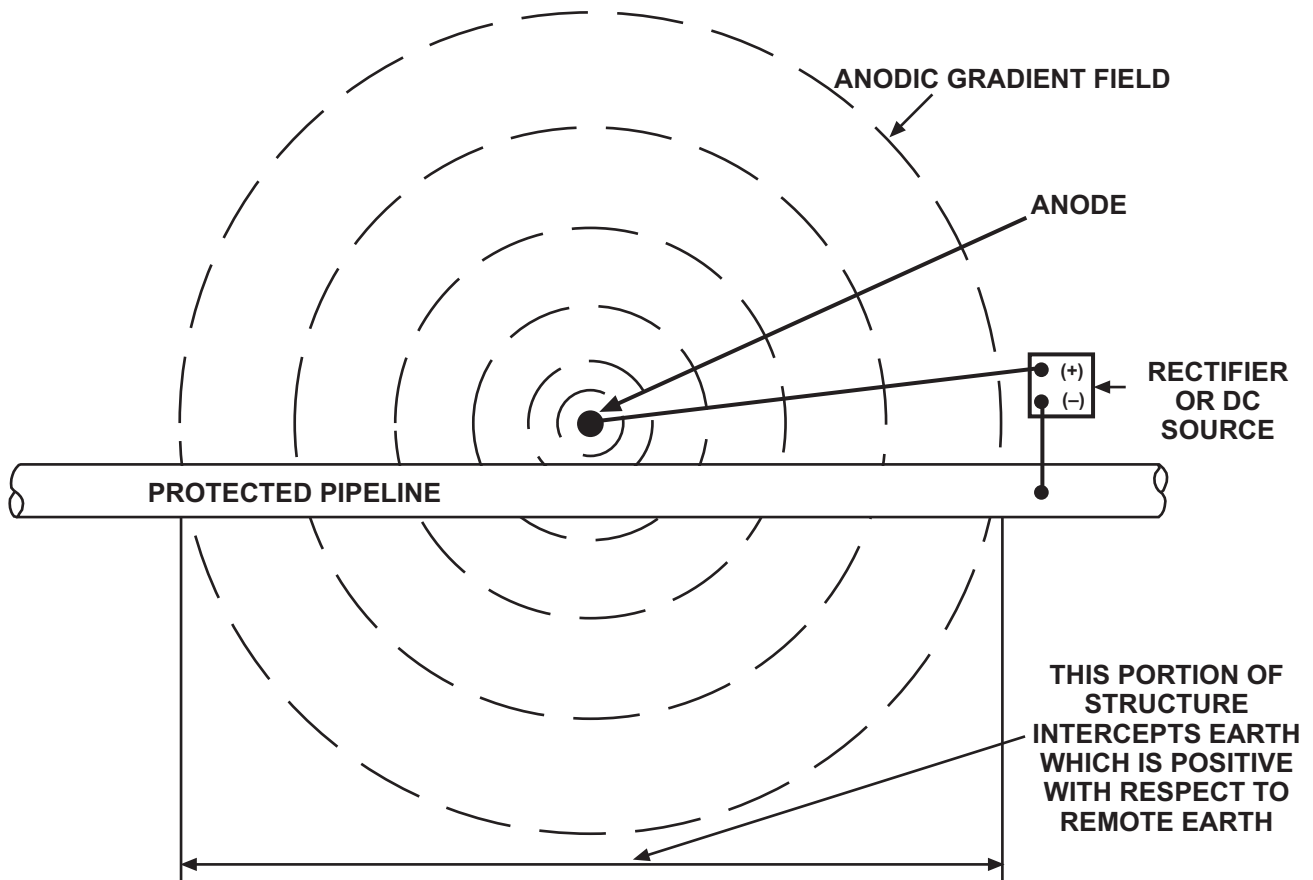

ANODE BED ARRANGEMENT FOR EARTH POTENTIAL SWING CATHODIC PROTECTION

FIGURE 5-8

potential of the earth in the vicinity of a structure. The earth potential swing concept involves having the protected structure intercept the anodic gradient field surrounding the distributed anode bed, as shown in the figure. The part of the structure that is within the gradient field of the anode bed is in soil which is electrically positive with respect to remote earth. This means that, within the anodic gradient field, the structure is negative with respect to adjacent earth, even though it may not be made more negative with respect to remote earth. Within the anodic gradient field, that part of the structure closest to the anode bed is normally most negative with respect to adjacent earth. Figure 5-9 shows how the gradient from the anode bed influences the potential of the pipeline-to-earth.

In designing a distributed anode bed, the designer considered that each individual anode created a gradient around itself and that the effect on the pipeline/structure is additive. Figure 5-10 shows the additive effect of two adjacent anodes.

A similar gradient effect is also created by a distributed anode bed that uses a linear anode.

The design of a distributed anode bed is similar to that of the remote anode bed as far as determining current requirements, calculating anode bed resistance-to-earth and sizing the DC output of the power supply.

In designing a distributed anode bed, the sizing of the header cable is more critical than for a remote anode bed. This is due to the length of the header cable and the associated voltage drops across the it.

DESIGN OF DEEP ANODE BED

When it is desirable to install an anode bed system which has many of the operating characteristics of a conventional anode bed, but for which there is no space available at the desired site location, the only way to install the anodes at a distance from the pipeline/structure is to install them deep below the

pipeline/structure.

Deep anode beds are also used when the soil strata are so arranged that the upper layers of soil are of high resistivity with underlying layers of lower resistivity.

A deep anode bed is usually more expensive to build than a conventional anode bed of comparable capacity. In addition, the anodes of a deep anode bed are well below grade level and are inaccessible for maintenance should failure occur in the anode material or in the connecting cables. Although there are replaceable deep anode bed systems on the market, it may be more economical to abandon a malfunctioning system in place and install a new anode bed close to the original one, rather than to attempt system repairs.

The design procedure for a deep anode bed is, for all practical purposes, the same as that for a conventional anode bed. The deep anode bed operates on the same concept as the conventional anode bed, making the protected pipeline/structure more negative with respect to the surrounding soil, as illustrated in Figure 5-11.

Graphite and high silicon-content cast iron anodes in coke breeze backfill are often used for deep anode beds (see Figure 5-12). In recent years, platinized anodes and mixed-metal oxide anodes in fluidized coke have become available for this use.

Other designs include the use of a steel casing as the anode material itself, or in cases where the drilled hole stays open and the water table is high enough, plain anodes without special backfill are installed inside the hole. In all cases, the upper portion of the installation (normally 50 to 100 feet) does not discharge current in order to avoid the gradients in the area of the pipeline/structure. This can be accomplished by installing a plastic casing in that section of the hole or by covering that section of the steel casing with a high dielectric tape/coating.

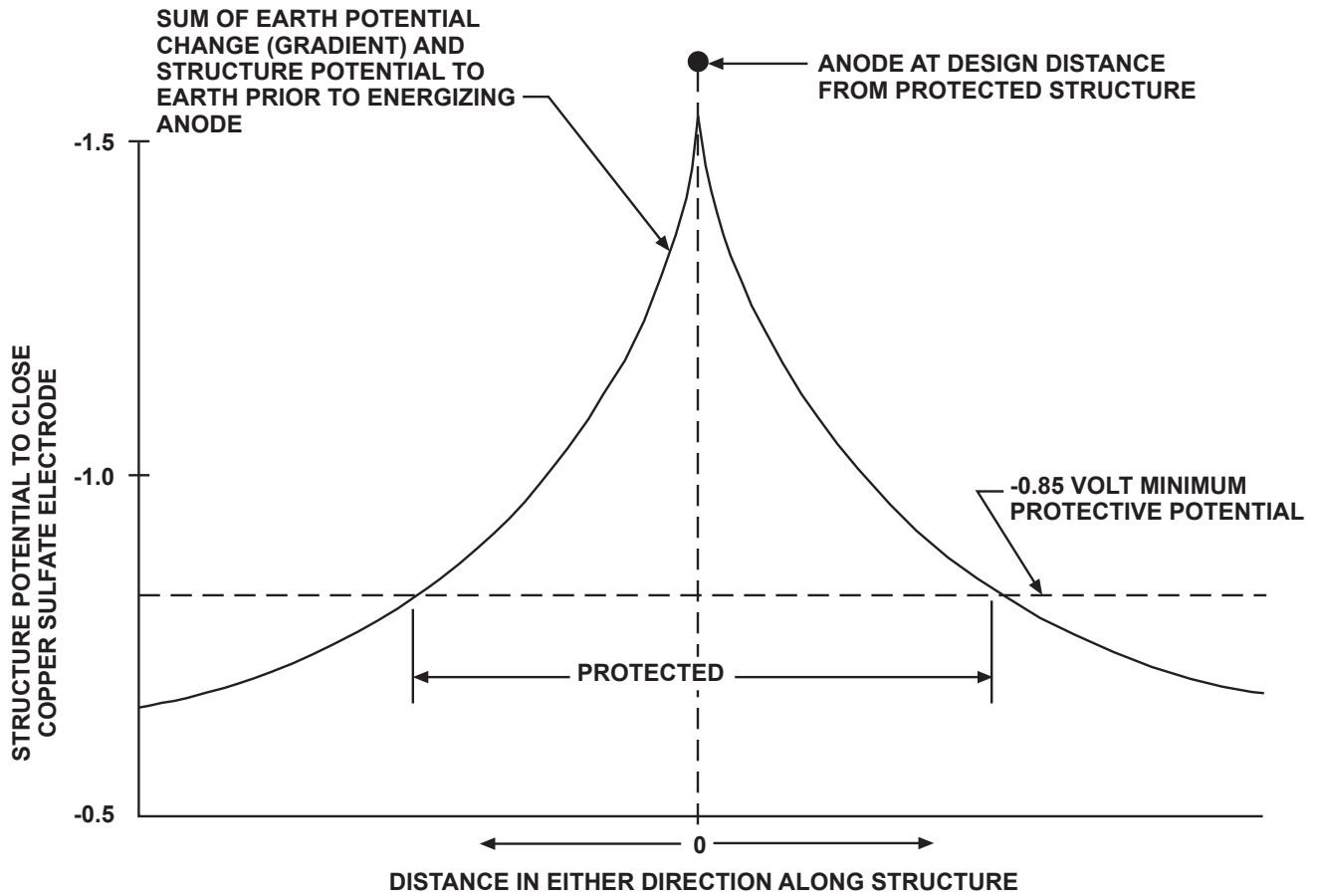

POTENTIAL GRADIENT FIELD AROUND A VERTICAL ANODE

FIGURE 5-9

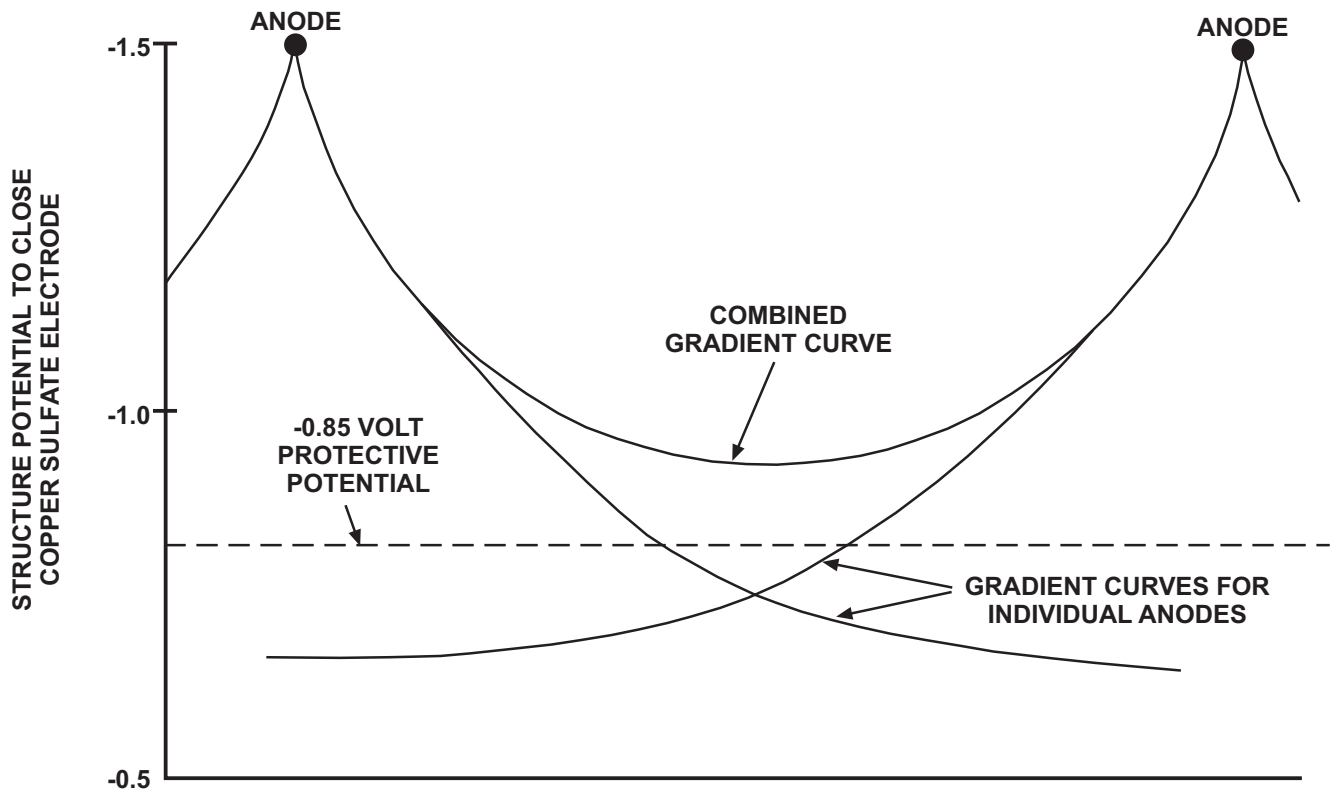

INTERACTION BETWEEN ADJACENT DISTRIBUTED ANODES

FIGURE 5-10

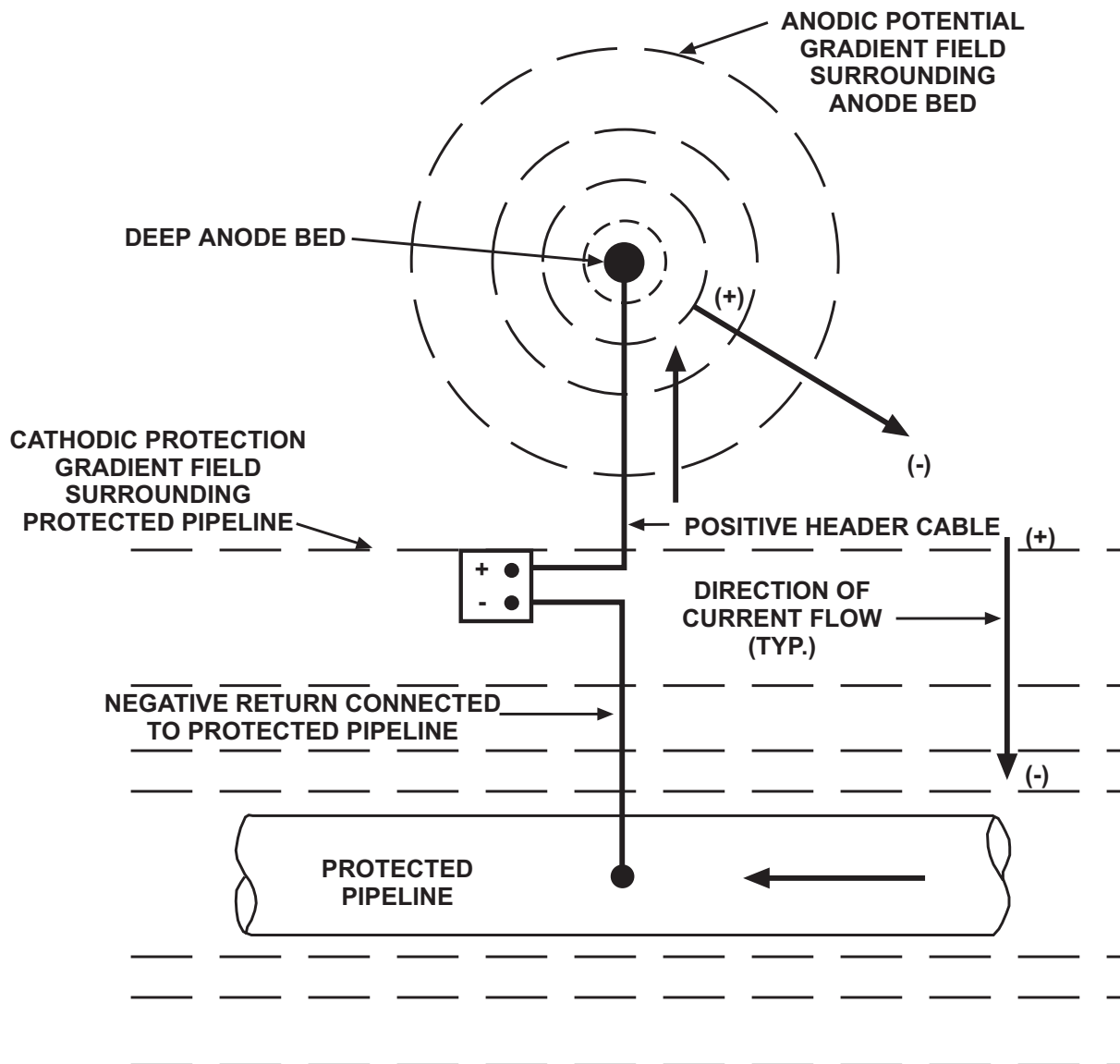

TYPICAL DEEP ANODE BED OPERATION

FIGURE 5-11

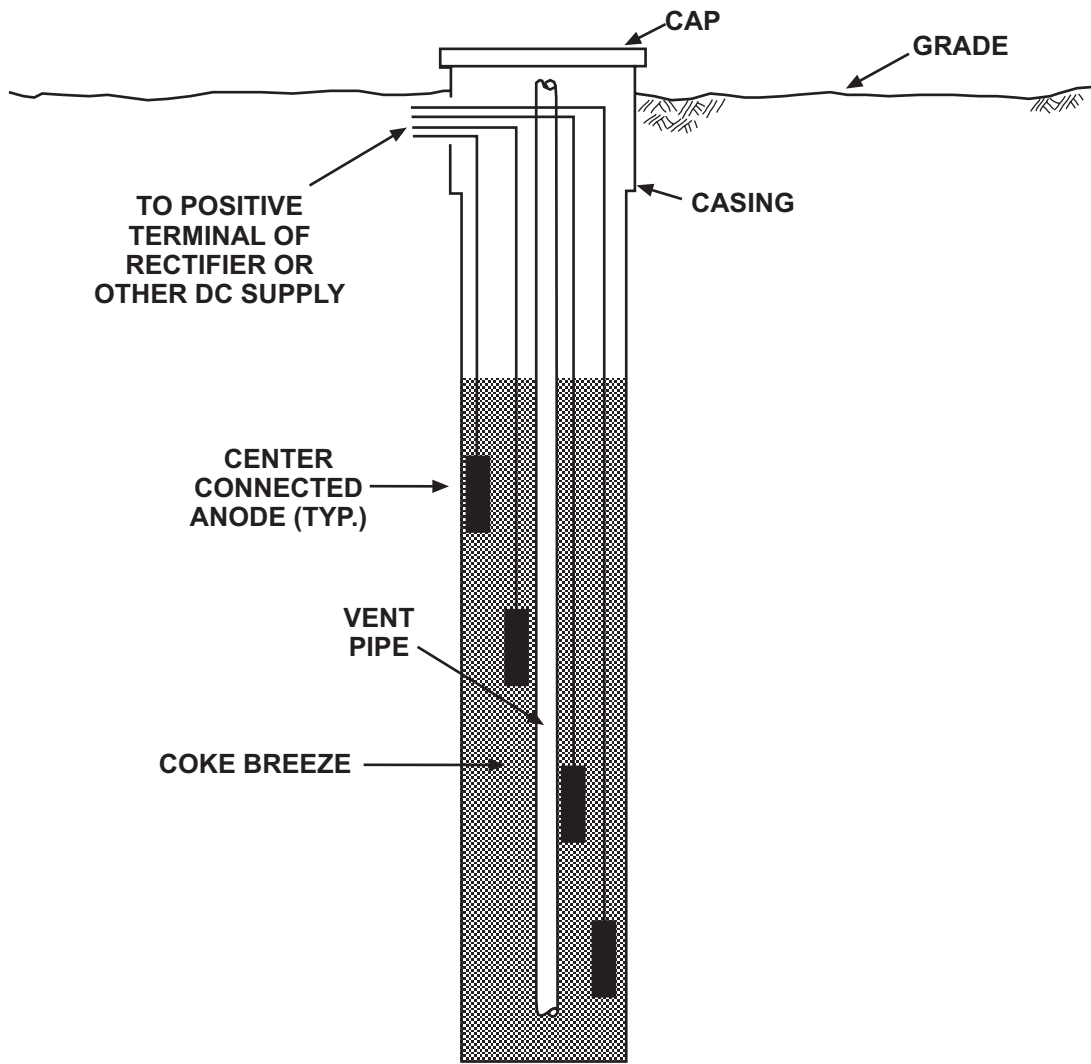

TYPICAL DEEP ANODE BED

FIGURE 5-12

However, it should be noted that, when designing a deep anode bed, the anode bed resistance-to-earth should be calculated using the total length of the backfill column install as illustrated by the following example:

EXAMPLE:

A deep anode bed consists of four 2" x 60" high-silicon chromium-bearing cast iron anodes with a column 40' long of coke breeze backfill in an 8" diameter hole. The effective soil resistivity at anode depth is 10,000 ohm-cm.

The deep anode bed resistance-to-earth can be calculated using H. B. Dwight's formula for a single vertical anode as follows:

$$R_v = \frac{0.00521 \cdot \rho \cdot \left(\ln \frac{8 \cdot L}{d} - 1 \right)}{L}$$

Where:

- R_v = Resistance-to-earth of single anode
- ρ = Effective soil resistivity = 10,000 ohm-cm
- L = Anode length = 40 ft
- d = Anode diameter = 0.667 ft

$$R_v = \frac{0.00521 \cdot 10000}{40} \cdot \left(\ln \frac{8 \cdot 40}{0.667} - 1 \right)$$

$$R_v = 6.73 \text{ ohms}$$

Many deep anode beds use conventional anodes with coke breeze backfill. One main problem that can develop with this type of installation is gas blocking. Chlorine gas evolves from the anode as a result of the current discharge. Gas blocking can render a deep anode bed useless. In order to eliminate, or at least reduce this problem, it is standard procedure to install a vent pipe which allows for the dissipation of the gas. Plastic materials not subject to deterioration by chlorine gas should be used for this vent pipe. Figure 5-12 shows the details of a typical deep anode bed.

Other problems associated with deep anode beds are:

1. Cable Insulation - Some types of cable insulation, such as the HMWPE, are attacked by chlorine gas and ozone. Special insulation, such as Kynar® or Halar®, should be used.
2. The anode-lead connection is a very critical point of the system, and steps should be taken to preclude later problems.
3. As the steel casing consumes, the resistance of the anode bed may increase because of the layer of iron oxide that develops.

CONCLUSIONS

Many parameters must be considered when designing an impressed current cathodic protection system. As previously discussed, these parameters include the following:

1. Current density required for protection,
2. Life expectancy of installation,
3. Anode bed layout,
4. Anode bed resistance, and
5. Rectifier output.

The corrosion control designer must be aware of these parameters to determine the most effective and economical system design.

There are basically three (3) different types of anode bed designs:

1. Remote or conventional,
2. Distributed, and
3. Deep anode.

Each type of anode bed has its own applications, and it is up to corrosion control personnel to ascertain which type would be more suited for each installation being considered.

CHAPTER 6

DESIGN OF GALVANIC ANODE CATHODIC PROTECTION

INTRODUCTION

Galvanic anodes remain an important and useful means for cathodic protection of pipelines and other buried structures. The application of cathodic protection utilizing galvanic anodes is nothing more than the intentional creation of a galvanic electrochemical cell in which two dissimilar metals are electrically connected while buried in a common electrolyte. In the “dissimilar metal” cell, the metal higher in the electromotive series (or more “active”) becomes anodic to the less active metal and is consumed during the electrochemical reaction. The less active metal receives cathodic protection at its surface due to the current flowing through the electrolyte from the anodic metal. The design of a galvanic cathodic protection system involves consideration of all factors affecting the proper selection of a suitable anode material and its physical dimension, placement, and method of installation to achieve a sufficient level of protection on the structure.

GALVANIC ANODE APPLICATION

General Uses

Galvanic anode installations are normally used for cathodic protection applications where relatively small amounts of protective currents are required and the resistivity of the electrolyte is low enough to permit their use. If current requirements are such that a large number of galvanic anodes would be required, it may be more economical to use an impressed current system, if possible.

Specific Uses

The following are some specific uses for galvanic anode cathodic protection systems:

1. For protecting structures where a source of DC or AC power is not available.
2. For clearing interferences caused by impressed current cathodic protection systems or other DC sources, where the interferences are not of great magnitudes.
3. For protecting sections of well-coated pipelines.
4. For providing hot-spot protection on bare pipelines where complete cathodic protection is impractical.
5. For supplementing impressed current systems where low spots or unprotected areas remain on the structure due to shielding effects or other reasons.
6. For temporary protection during construction of a pipeline until the impressed current system is installed.
7. For AC mitigation.

GALVANIC ANODE CATHODIC PROTECTION DESIGN PARAMETERS

Galvanic Anode Selection

The first step in designing a galvanic anode system is the selection of the anode material. Corrosion control personnel must consider the

following to determine the most economical anode material to use:

1. Required amount of protective current
2. Total weight of each type of anode
3. Anode life calculations
4. Desired life of installation
5. Efficiency of anode types
6. Theoretical consumption rate
7. Driving potential
8. Soil or water resistivity
9. Cost of anode material
10. Shipping costs
11. Degree of skill required for installing the galvanic anode system

Table 6-1 shows some of these parameters for several anode materials. The order of priority of the above factors will probably change for each installation.

Anode Current Efficiency

Anode current efficiency is a measure of the percentage of the total anode current output which is available in a cathodic protection circuit. The remaining current is dissipated in the self-corrosion of the anode material.

From Table 6-1 it should be noted that zinc has high current efficiency. Magnesium on the other hand, is shown to have an efficiency of approximately 50 percent. Although this efficiency figure is used quite commonly, it is not a constant and can be even less at low current outputs.

Current Requirements

The determination of the amount of current required to protect a structure is one of the most important design parameters. Current requirements for a structure can be determined by conducting current requirement tests on the structure. This method was discussed in detail

in the previous chapter for the design of the impressed current system. These approaches are identical for the galvanic anode system.

Electrolyte Resistivity

The selection of the galvanic anode material is primarily dependent upon the resistivity of the surrounding electrolyte (soil). As discussed in Chapter 3, the low driving potentials of the various galvanic anode material alloys limit their economical use to the lower resistivity soils. Zinc anodes are seldom used in soils with resistivity values greater than 1,500 ohm-cm. Magnesium anodes are generally used in soils with resistivity values between 1,000 and 10,000 ohm-cm. Ideally, the galvanic anode bed should be installed in the area of lowest resistivity. Soil resistivity surveys should be conducted as described in Chapter 5 of the Basic Course.

Total Circuit Resistance

Total circuit resistance depends upon the following:

- Anode bed resistance - R_{abed}
- Resistance of interconnecting cables - R_{ckt}
- Resistance to earth of the cathode (structure) - R_{cathode}

The electrical circuit equivalent of the current output of a galvanic anode is depicted in Figure 6-1.

It should be noted that as corrosion personnel develop experience, they will be able to determine the conditions under which some of the above factors can be considered negligible.

Anode Bed Resistance - (R_{abed})

The resistance of the galvanic anode bed is more critical than that of the impressed current system due to the fact that the driving voltage of the anodes is limited. The current output is limited by the potential difference between the structure and the anode material.

TABLE 6-1**Typical Operating Characteristics of Galvanic Anodes**

Galvanic Anode Material	Theoretical Output Characteristics (amp-hr/lb)	Actual Output* Characteristics (amp-hr/lb)	Consumption Rates (lb/amp-yr)	Current Efficiency	Negative Potential (Volts) to CuCuSO₄
Zinc (Mil-A-18001 U)	370	370	23.7	90%	1.10
Magnesium (H-1 Alloy)	1000	250 - 580	15 - 35	25 - 58%	1.40 - 1.60
Magnesium (High Potential)	1000	450 - 540	16 - 19	45 - 54%	1.70 - 1.80

* Based on shown current efficiencies.

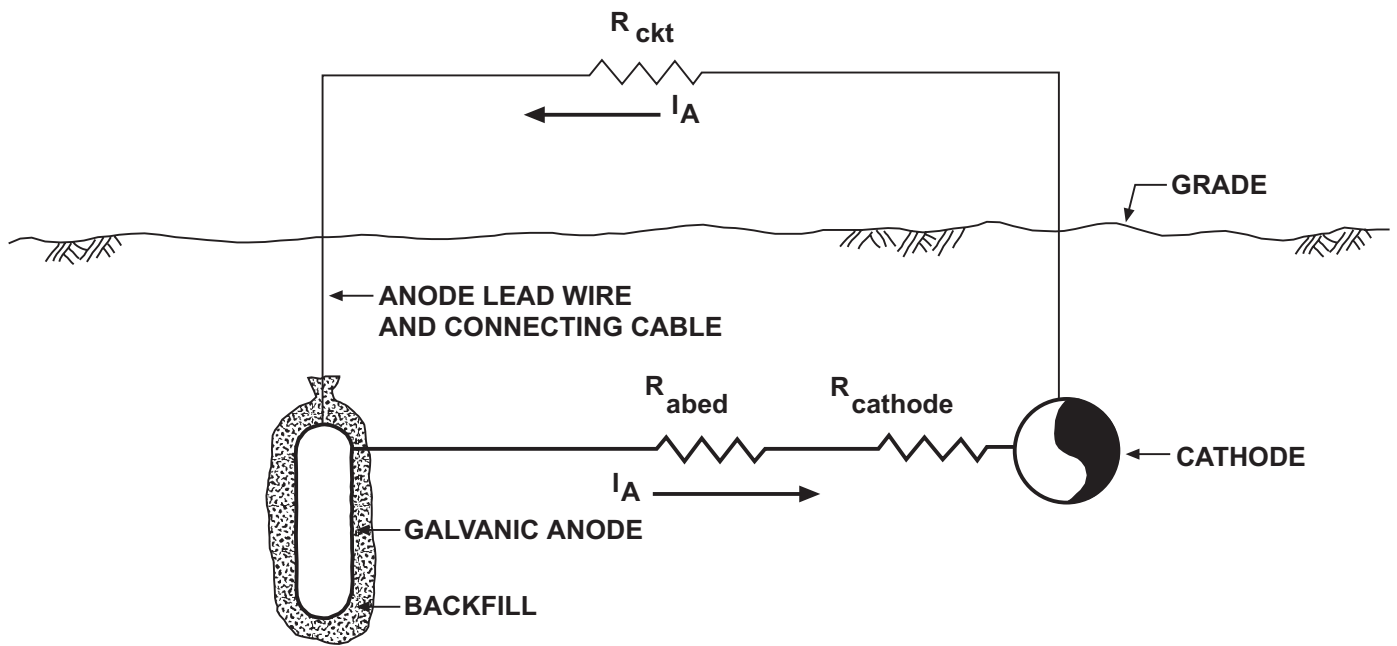

**GALVANIC ANODE SYSTEM
ELECTRICAL CIRCUIT**

FIGURE 6-1

Anode bed resistance of a galvanic anode system can be calculated using the same formulas used to determine the resistance of the impressed current anode bed.

Example:

Calculate the resistance of a galvanic anode bed consisting of six prepackaged 60 lb zinc anodes (5" x 66" long) spaced 15' apart, center-to-center, average soil resistivity in the area is 1,500 ohm-cm.

$$R_{\text{abed}} = \frac{0.00521 \cdot \rho}{N \cdot L} \cdot \left(\ln \frac{8 \cdot L}{d} - 1 + \frac{2 \cdot L}{S} \cdot \ln 0.656 \cdot N \right)$$

Where:

- R_{abed} = resistance of the total number of vertical anodes in parallel (ohms)
- ρ = electrolyte resistivity (ohm-cm)
- L = length of anode (feet)
- d = anode diameter in feet
- N = number of anodes in parallel
- S = spacing between anodes in feet

$$R_{\text{abed}} = \frac{0.00521 \cdot 1500}{5.5 \cdot 6} \cdot \left(\ln \frac{8 \cdot 5.5}{0.417} - 1 + \frac{2 \cdot 5.5}{15} \cdot \ln 0.656 \cdot 6 \right)$$

$$R_{\text{abed}} = 1.10 \text{ ohms}$$

Resistance of Interconnecting Cables (R_{ckt})

The resistance of the interconnecting cables (R_{ckt}) is normally negligible in the design of galvanic anode cathodic protection systems. The IR drops in the cables are usually insignificant because of the low current output of this type of installation. When the resistance of the interconnecting cables is to be included in the overall system resistance, R_{ckt} can be calculated for all practical purposes, using the following formula:

$$R_{\text{ckt}} = \text{Resistance per ft of cable (Table 6-2)} \times \text{Length of cable}$$

Cathode-to-Earth Resistance (R_{cathode})

The cathode-to-earth resistance is resistance between the structure and electrolyte.

On a coated pipeline this resistance can be calculated by first determining the effective coating resistance (R_c) (as discussed in Chapter 2) and then using the following formula:

$$R_{\text{cathode}} = R_c/n$$

Where:

- R_{cathode} = resistance of pipeline to earth (ohms)
- R_c = effective coating resistance - ohms per average square foot of surface area (ohm-ft²)
- n = the number of square feet of pipeline surface area

Example:

Assuming a 10-mile section of 36" diameter pipe with a coating resistance of 50,000 ohms (R_c) for one average square foot. The pipe-to-earth resistance (R_{cathode}) can be calculated as follows:

Step No. 1

Calculate surface area of pipeline (n):

$$n = \pi \cdot \text{pipe diameter (ft)} \cdot \text{length of pipe (ft)}$$

$$n = 3.14 \times (36/12) \times (10 \times 5280)$$

$$n = 497,376 \text{ sq. ft.}$$

Step No. 2

Calculate pipe-to-earth resistance:

$$R_{\text{cathode}} = R_c/n = 50,000/497,376$$

$$R_{\text{cathode}} = R_c/n = 0.10 \text{ ohm}$$

Anode Life

Having arrived at an anode configuration that will produce the required current output is not

TABLE 6-2**Resistance of Concentric Stranded Copper Single Conductors**

Size AWG	Max. DC Resistance @ 20° C (ohms/1000 ft)
14	2.5800
12	1.6200
10	1.0100
8	0.6400
6	0.4030
4	0.2540
3	0.2010
2	0.1590
1	0.1260
1/0	0.1000
2/0	0.0795
3/0	0.0631
4/0	0.0500
250 MCM	0.0423

sufficient in itself. An examination of the estimated life of the anodes must be undertaken in order to determine whether the design will provide protection for a reasonable period of time. The following expression may be used to calculate the estimated life of the anode:

$$\text{Years Life} = \frac{\text{Th} \times \text{A} \times \text{E} \times \text{UF}}{\text{Hr} \times \text{I}}$$

Where:

Th = Theoretical amp-hours/lb

A = Anode weight (lbs)

E = Current Efficiency expressed as a decimal

UF = Utilization Factor - typically 85 percent expressed as a decimal (0.85) -- the point at which the anode should be replaced even though the anode metal may not be entirely consumed.

Hr = Hours per year

I = Current (amps)

The utilization factor accounts for a reduction in output as the surface area of the anode decreases with time, limiting the anode output. This factor is usually assumed to be 0.85.

1. For magnesium:

$$\text{Years Life} = \frac{0.114 * \text{A} \times \text{E} \times \text{UF}}{\text{I}}$$

2. For zinc:

$$\text{Years Life} = \frac{0.0424 * \text{A} \times \text{E} \times \text{UF}}{\text{I}}$$

* These constants are derived by dividing the theoretical ampere-hours per pound by the number of hours in a year.

As an illustration, compare the lives of ten

pound anodes of magnesium and zinc, each discharging 0.1 amp. Assume 90% current efficiency for zinc and 50% for magnesium. Each anode is assumed to require replacement when it is 85% consumed.

Using the above formulas, the life expectancies work out as follows:

1. For magnesium:

$$\text{Years Life} = \frac{0.114 \times 10 \times 0.50 \times 0.85}{0.10} = 4.8 \text{ years}$$

2. For zinc:

$$\text{Years Life} = \frac{0.0424 \times 10 \times 0.90 \times 0.85}{0.10} = 3.2 \text{ years}$$

The calculated life figures reflect the effect of different rates of consumption of the two metals as well as the effect of current efficiency.

GALVANIC ANODE DESIGN CALCULATIONS

A well-coated pipe is 36 inches in diameter and 2,500 feet long. The average soil resistivity in the area is 1,000 ohm-cm. The desired system life expectancy is 20 years.

Step No. 1

Choose the anode material. Based on the fact that magnesium has a higher amp-hr/lb characteristic and lower consumption rate than zinc (see Table 6-1) magnesium is selected.

Step No. 2

Calculate the surface area (n) to be protected:

$$n = \pi \cdot \text{pipe diameter (ft)} \cdot \text{length of pipe (ft)}$$

$$n = 3.14 \times (36/12) \times (2500)$$

$$n = 23,550 \text{ ft}^2$$

Step No. 3

Calculate current requirements. The anode bed should be designed to achieve a satisfactory amount of polarization. After polarization galvanic anodes tend to self-regulate and the current output at the anode bed will decline while protection is maintained. As a rule of thumb, the amount of current required to polarize the pipe is four times the amount of current required to maintain protection.

- a. Current required to maintain protection (I_{protect}) on the pipe can be calculated as follows, assuming a current requirement of 0.003 mA/ft², typical for a well coated, electrically isolated pipe. This is based on 1.5 mA/ft² of exposed metal and on 0.2% coating damage.

$$I_{\text{protect}} = 0.003 \text{ mA/ft}^2 \times \text{surface area}$$

$$I_{\text{protect}} = 0.003 \text{ mA/ft}^2 \times 23,550 \text{ ft}^2$$

$$I_{\text{protect}} = 71 \text{ mA} = 0.071 \text{ Amperes}$$

- b. The current required to polarize (I_{polarize}) the pipe, by rule of thumb is based on a current requirement of 0.012 mA/ft² (four times current required for protection). This also approximated the current required should coating deteriorate to a total of 0.8% damage.

$$I_{\text{protect}} = 0.012 \text{ mA/ft}^2 \times \text{surface area}$$

$$I_{\text{protect}} = 0.012 \text{ mA/ft}^2 \times 23,550 \text{ ft}^2$$

$$I_{\text{protect}} = 283 \text{ mA} = 0.283 \text{ Amperes}$$

Step No. 4

Determine the minimum amount of anode material (W) required to provide an anode bed life of 20 years, based on the current required to polarize the pipe.

$$\text{Years Life} = \frac{0.114 \times W \times E \times UF}{I_{\text{protect}}}$$

$$20 = \frac{0.114 \times W \times 0.50 \times 0.85}{0.283}$$

$$W = 117 \text{ lbs of magnesium}$$

Based upon the above calculated anode material weight requirement, it appears that 7 - 17 lb anodes (4" x 4" x 17"), with backfill outer dimensions of 7.5" x 24", will provide sufficient anode material for the desired life.

Step No. 5

Calculate the anode bed resistance (R_{abed}) for an anode bank assuming center-to-center anode spacing of 15 feet.

$$R_{\text{abed}} = \frac{0.00521 \cdot \rho}{N \cdot L} \cdot \left(\ln \frac{8 \cdot L}{d} - 1 + \frac{2 \cdot L}{S} \cdot \ln 0.656 \cdot N \right)$$

$$R_{\text{abed}} = \frac{0.00521 \cdot 1000}{7 \cdot 2} \cdot \left(\ln \frac{8 \cdot 2}{0.625} - 1 + \frac{2 \cdot 2}{15} \cdot \ln 0.656 \cdot 7 \right)$$

$$R_{\text{abed}} = 0.99 \text{ ohm}$$

Step No. 6

Calculate the cathode to earth resistance (R_{cathode}) assuming an effective coating resistance (R_c) of 15,000 ohm-ft².

$$R_{\text{cathode}} = R_c / \text{surface area}$$

$$R_{\text{cathode}} = 15,000 \text{ ohm-ft}^2 / 23,550 \text{ ft}^2$$

$$R_{\text{cathode}} = 0.64 \text{ ohm}$$

Step No. 7

Calculate the connecting cable resistance (R_{ckt}) assuming the use of approximately 105 feet of No. 6 AWG wire.

$$R_{\text{ckt}} = \text{Resistance of wire} \times \text{length}$$

$$R_{\text{ckt}} = 0.403 \text{ ohm/1000 feet} \times 105 \text{ ft}$$

$$R_{\text{ckt}} = 0.042 \text{ ohm}$$

Step No. 8

Calculate anode bed current output (I_{abed}). Assume the anode potential to be -1.55 volts and you want to polarize the pipe to -1.0 volt.

$$I_{\text{abed}} = \frac{\text{Anode Potential} - \text{Cathode Potential}}{R_{\text{abed}} + R_{\text{cathode}} + R_{\text{ckt}}}$$

$$I_{\text{abed}} = \frac{1.55 - 1.0}{0.99 + 0.64 + 0.042} = 0.329 \text{ Ampere}$$

The anode bed current output (I_{abed}) calculated above exceeds the previously calculated current values required to polarize and protect the structure, therefore the design will be effective in providing cathodic protection. Once the pipe polarizes (usually within a few months), the anode current will drop to the protective level of about 0.071 amperes, thus further extending anode life. Also, using the polarizing current in these calculations allows for coating deterioration over time.

Figure 6-2 shows a detail of a typical system layout for this design.

Simplified Calculations

From the previous example, we can see that it can be rather time consuming to calculate the various resistive factors required to design a galvanic anode bed, and often certain assumptions must be made that result in an approximate current output calculation. The output of magnesium and zinc anodes has been fairly well documented under varying conditions, and many graphs, tables, and charts have been developed. These references can be used by corrosion control personnel to provide a simplified and reasonably accurate means of determining anode current outputs under normal operating conditions. One such reference, widely used, was developed by D. A. Tefankjian⁽¹⁾. The following equations can be used to determine the current output for magnesium or zinc anodes, utilizing correction factors provided in Tables 6-3 and 6-4.

Bare or Poor Coating	Good coating
$i_m = \frac{150000 \cdot f \cdot y}{\rho}$	$i_m = \frac{120000 \cdot f \cdot y}{\rho}$
$i_z = \frac{50000 \cdot f \cdot y}{\rho}$	$i_z = \frac{40000 \cdot f \cdot y}{\rho}$

Where:

i_m = current output for magnesium anode in milliamperes

i_z = current output for zinc anode in milliamperes

ρ = soil resistivity in ohm-cm

f = anode shape factor from Table 6-3

y = driving voltage factor from Table 6-4

The equations assume a minimum soil resistivity of 500 ohm-cm and a distance between anode and structure of 10 feet. The equations and factors were developed based on bare or poorly coated structures. Because of the increased circuit resistance occurring with well coated structures, the calculated current value should be reduced by 20 percent. This can be done by multiplying i as shown above, by 0.80.

Example

Calculate the number of anodes required to protect 10,000 feet of well coated, electrically isolated 16" pipe at a pipe-to-soil potential of 0.85 volts in a soil of 2,500 ohm-cm. Assume a current requirement of 1.5 mA/exposed square foot of metal and coating damage of 1%. Use 32 lb pre-packaged standard alloy magnesium anodes and design for a 20 year anode life.

Step 1

Calculate the surface area (n) to be protected.

$$n = \pi \cdot \text{pipe diameter (ft)} \cdot \text{length of pipe (ft)}$$

$$n = \pi \cdot (16/12) \cdot 10000 = 41,888 \text{ ft}^2$$

$$\begin{aligned} \text{Surface area to be protected} &= 41,888 \times 1\% \\ &= 419 \text{ ft}^2 \end{aligned}$$

Step 2

Calculate the current required:

$$419 \text{ ft}^2 \times 1.5 \text{ mA/ft}^2 = 629 \text{ mA}$$

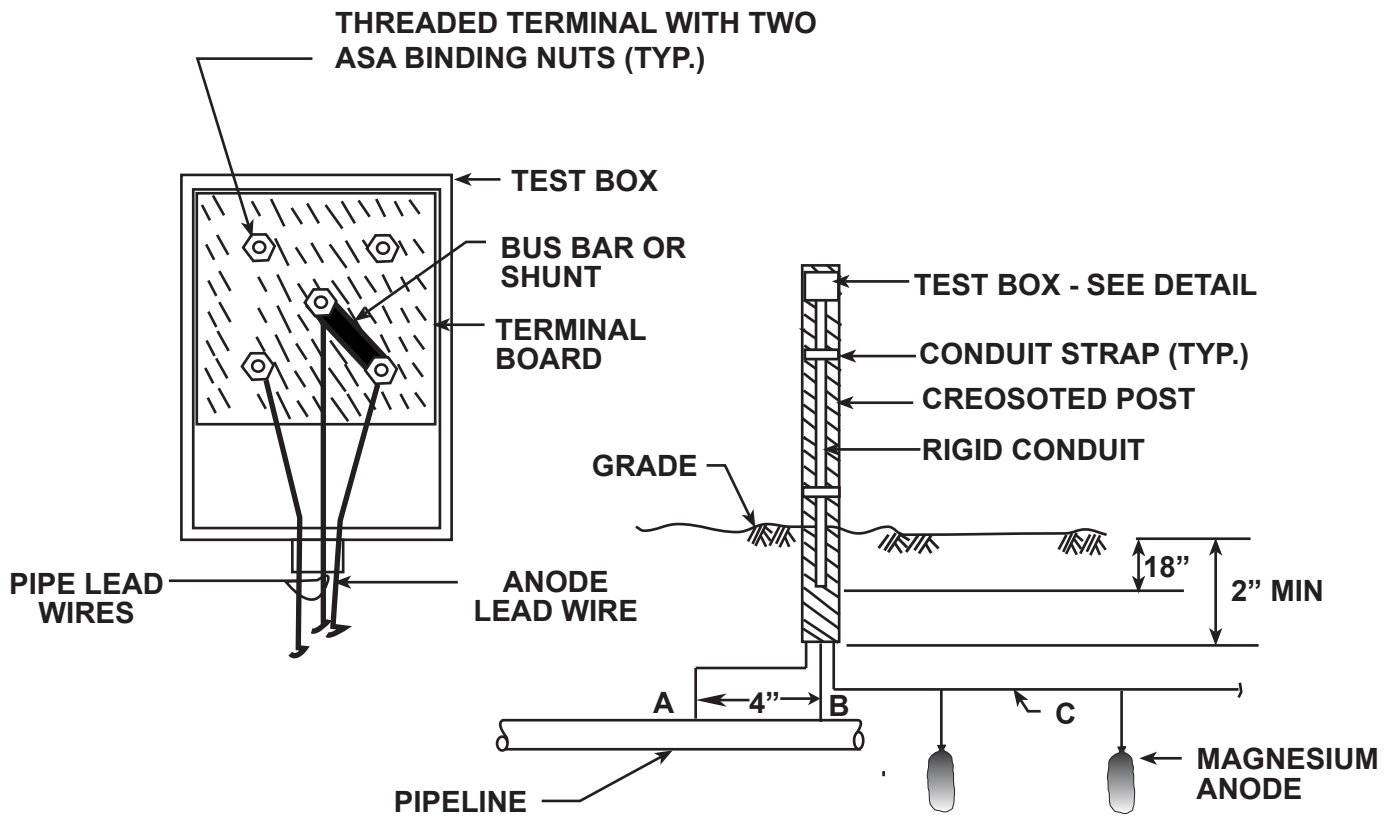

**TYPICAL GALVANIC ANODE
SYSTEM INSTALLATION**

FIGURE 6-2

TABLE 6-3**Anode Shape Factors (f)**

Anode Weight (lbs)	Anode	Factor (f)
Standard Anodes		
3	(Packaged)	0.53
5	(Packaged)	0.60
9	(Packaged)	0.71
17	(Packaged)	1.00
32	(Packaged)	1.06
50	(Packaged - anode dimension 8" dia x 16")	1.09
50	(Packaged - anode dimension 5" x 5" x 31")	1.29
Long Anodes		
9	2.75" x 2.75" x 26" backfill 6" x 31"	1.01
10	1.50" x 4.50" x 72" backfill 4" x 78"	1.71
18	2.00" x 2.00" x 72" backfill 5" x 78"	1.81
20	2.50" x 2.50" x 60" backfill 5" x 66"	1.60
40	3.75" x 3.75" x 60" backfill 6.5" x 66"	1.72
42	3.00" x 3.00" x 72" backfill 6" x 78"	1.90
Extra-Long Anodes		
15	1.6" dia x 10' backfilled to 6" dia	2.61
20	1.3" dia x 20' backfilled to 6" dia	4.28
23	2.0" dia x 10' backfilled to 8" dia	2.81

TABLE 6-4**Driving Voltage Correction Factors (Y)**

P/S	Standard Magnesium	High-Potential Magnesium	Zinc
-0.70	1.21	2.14	1.60
-0.80	1.07	1.36	1.20
-0.85	1.00	1.29	1.00
-0.90	0.93	1.21	0.80
-1.00	0.79	1.07	0.40
-1.10	0.64	0.93	--
-1.20	0.50	0.79	--

TABLE 6-5**Multiple Anode Adjustment Factors**

No of Anodes in parallel	Adjustment Factors (anode spacing in feet)			
	5'	10'	15'	20'
2	1.839	1.920	1.946	1.965
3	2.455	2.705	2.795	2.848
4	3.036	3.455	3.625	3.714
5	3.589	4.188	4.429	4.563
6	4.125	4.902	5.223	5.411
7	4.652	5.598	6.000	6.232
8	5.152	6.277	6.768	7.035
9	5.670	6.964	7.536	7.876
10	6.161	7.643	8.304	8.679

Step 3

Calculate the anode current output: (i_m)

$$i_m = \frac{120000 \cdot f \cdot y}{\rho} \Rightarrow i_m = \frac{120000 \cdot 1.06 \cdot 1.00}{2500}$$

$$i_m = 50.9 \text{ mA (0.0509 amps)}$$

Step 4

Calculate the number of anodes required:

$$\text{Number} = \frac{\text{current requirement}}{\text{anode output}}$$

$$\text{Number} = \frac{629 \text{ mA}}{50.9 \text{ mA / Anode}}$$

$$\text{Number} = 12.4 \text{ or } 13 \text{ anodes}$$

Anodes could be spaced evenly along the line at intervals of 10,000/13 or about every 769 feet.

Step 5

Calculate anode life:

$$\text{Life} = \frac{0.114 \times W \times E \times UF}{\text{Current (amps)}}$$

$$\text{Life} = \frac{0.114 \times 32 \times 0.50 \times 0.85}{0.0509}$$

$$\text{Life} = 30.5 \text{ years}$$

The twenty year design life is satisfied.

Other Factors

The calculated result assumes an even distribution of current over the calculated length of pipe, which is not realistic. The greatest is in close proximity to the anode and decreases with distance. Therefore, assuming uniform

coating and soil, a greater amount of current is available to the pipe closest to the anode. The attenuation of current is more pronounced as coating quality decreases, so an individual galvanic anode protecting a "hot spot" on a bare pipe will protect a much smaller area of pipe than that indicated above. For a series of individually connected anodes, the potential increase on the pipe that results between adjacent anodes, is additive.

Anodes are commonly connected in parallel in order to achieve higher current output at a given location. The approximate current output of a group of anodes can be calculated by multiplying the calculated current output of a single anode by the appropriate adjusting factor indicated in Table 6-5.

Example

The current output (I_t) of six 32 lb pre-packaged standard alloy magnesium anodes connected in parallel can be calculated as follows, based on a current output of 50.88 mA for an individual anode. Assume an anode spacing of 10 feet.

$$I_t = 50.88 \text{ mA} \times \text{Adjusting Factor (Table 6-5)}$$

$$I_t = 50.88 \text{ mA} \times 4.902$$

$$I_t = 249.41 \text{ mA}$$

SPECIFICATION AND MAINTENANCE OF GALVANIC ANODE INSTALLATIONS

Specifications must be written to insure that the materials and methods, upon which the design has been predicated, are utilized. There should be no deviation from these specifications unless approved by the person in charge of design. Inspection should be performed during system installation to guarantee that the specification of material and procedures are adhered to.

The maintenance of galvanic anode systems consists of routine surveys and, when necessary, repairs/replacement. A survey to determine the operating levels of the system should be conducted annually and the data

recorded in a permanent log.

Current measurements will enable the life of the anode to be predicted, and their timely replacement scheduled accordingly. Additional anodes should be installed where low potentials warrant their installation. Damaged facilities should be repaired to ensure that adequate levels of protection are maintained.

CONCLUSIONS

As was the case with the design of the impressed current cathodic protection system, the design of the galvanic anode system warrants the consideration of various factors. These factors include the following:

1. Soil resistivity
2. Current Requirements
3. Anode Material Selection
4. Life Expectancy

The resistivity of the soil and the resistance to earth of the structure being protected have a great impact on design and system performance when using galvanic anodes. This is due to the fact that the driving potential of the system is limited to the natural potential difference between the anode material and the structure being protected.

Reference

1. Tefankjian, D.A., 1974. "Application of Cathodic Protection". Proceedings of the 19th Annual Appalachian Underground Corrosion Short Course, pp 122-138.

CHAPTER 7

MIC INSPECTION AND TESTING

INTRODUCTION

Microbiologically induced corrosion (MIC) has been actively studied in recent years because of its potentially deleterious effect on important underground structures, such as pipelines. The most well known bacteria associated with pipeline corrosion are the sulfate reducing bacteria (SRB). These bacteria are active in deaerated environments often associated with wet, poorly drained soils (that promote oxygen exclusion), require a nutrient that is near the pipe and often the carbonaceous material of the coating, and have a sulfurous (rotten eggs) odor associated with the sulfate reduction process. If conditions change, they may become dormant and another type of bacteria may become active. Because bacteria live in communities, there is also a synergistic effect among them whereby the reaction products of one may act as a nutrient for another. Thus, it is important to test for more than one type of bacteria. However, it is important to recognize also that the presence of bacteria does not necessarily mean that they are active or that they pose a threat to the integrity of the structure.

Research studies have shown that MIC can be characterized by the chemical, biological, and metallurgical features associated with the suspected site. The type and form of pitting corrosion is often distinctively associated with MIC. Chemical and biological data are supportive, and are useful for estimating whether a potential for MIC exists.

The following sections give a procedure for inspecting the dig site, assessing the coating

and steel at coating damage and suspected MIC areas; sampling the soil, groundwater, or pipe-surface products for MIC testing; carrying out the MIC testing using commercially available field test kits; and visually inspecting the corroded areas for MIC characteristics.

SITE INSPECTION

Before excavation of the pipeline, the topography of the surrounding area of the dig and the soil type should be noted. This information is useful in assessing the likely conditions that can support various types of bacteria. For example, low, wet areas with clay soils collect and hold water, and tend to exclude oxygen to promote deaerated conditions. Soils with more sand or rock allow water and/or air to migrate more readily to the pipe and promote more aerated conditions. Higher elevations with rocky soils tend to be better drained and drier, and tend to promote more aerated conditions.

Exposure of the pipe should be slow and careful to avoid damage to the pipe and areas of sampling. Remove soil from the pipe surface carefully to expose the coating surface. Do not remove any products adhering to the coating surface. Note and record the following on an appropriate form:

- Coating type (e.g., coal tar, asphalt, bitumen, tape), type of damage (e.g., disbonding, holidays, blistering, seam tenting, cracking, and wrinkling), extent of damage (% of exposed area), and location (circumferential and longitudinal position on pipe in relation to weld seams and coating

seam, if present)

- Corrosion and/or cathodic protection surface products present
 - Location (see above)
 - Type (e.g., deposit, nodule, or films)
 - Color (e.g., brown, black, white, or gray)
 - Smell (e.g., none, earth, rotten eggs)
- Soil type (e.g., sand, gravel, silt, clay, rock)
- Soil moisture (e.g., wet, dry).

Do not remove any coating or surface products at this time. Only the person performing the field test should remove coating or products from the pipe surface at his discretion until testing is complete.

COATING INSPECTION

Coating inspection for MIC testing purposes should precede any other type of coating evaluation planned.

Identify likely area of MIC or other forms of corrosion from the visual inspection above. Carefully remove the damaged coating using a clean knife to expose the steel beneath. If a liquid is present, take a sample using a syringe or cotton swab following procedures to be described below for testing purposes. If the area is not to be tested for MIC, the steel surface condition and liquid pH should be evaluated.

Visually inspect the steel surface for corrosion. Where possible, use a gauge to measure the depth of corrosion. Also, determine the length of the corroded area in relation to the circumferential and longitudinal position.

The pH of the liquid may be tested using hydrion paper or its equivalent. Carefully slice the coating to a length to allow the test paper to be slipped behind the coating. Press the

coating against the pH paper for a few seconds and remove, then remove the pH paper. Note and record the color of the paper in relation to the chart provided with the paper. Determine the pH of groundwater away from the pipe in the ditch if possible for reference. Compare the two pH values to determine if the pH near the pipe is elevated. An elevated pH indicates the presence of cathodic protection current reaching the pipe. A pH above about 9 would be considered elevated for most soils. It is not uncommon to determine a pH of 12 to 14 for well protected steel.

MIC AND DEPOSIT SAMPLING

Once the pipe is exposed, the soil and any suspected deposits must be sampled and tested immediately. The coating around the suspected area of corrosion should be carefully removed using a knife or similar instrument. Sample contamination must be kept to a minimum. Therefore, avoid touching the soil, corrosion product, or film with hands or tools other than those to be used in sample collection and provided with the test kits.

MIC SAMPLING AND TESTING

A minimum of three samples should be collected and tested. Two samples should be taken from one or more of the following locations:

- Undisturbed soil immediately next to the exposed pipe steel surface or at an area of coating damage
- A deposit associated with visual evidence of pipe corrosion
- A scale or biofilm on the steel surface or the backside of the coating
- Liquid trapped behind the coating.

The third sample should be taken from fresh, undisturbed soil at pipe depth, at least 1 m transverse to the pipe. This location, such as the ditch wall, will act as a reference from which

to determine if the bacteria count near the pipe is elevated.

Additional samples may be taken and tested from other locations where bacterial activity is suspected.

Collect the soil, film, or liquid sample following the detailed procedures outlined in the test kit. Inoculate the vials at the dig site. Mark the side of each vial with the appropriate dilution number, as well as the tray next to it, using a permanent marker. Each tray should be marked to identify the following:

- Date and time sample collected
- Location where the sample was taken
- Location of the dig site.

This same information must be put on the original box in which the sample tray is to be stored. The box of samples should be stored at ambient temperature with the box top closed; it is not necessary to incubate the samples at elevated temperature. All unused test kits should be stored in a refrigerator to prolong shelf life.

After one (1), two (2), and five (5) days, view the sample bottles and record the result. Use the rating number (1 through 5) corresponding to the highest bottle number to give a positive result. Also, record the number of the type of response, such as 2-Cloudy, shown on the Positive Reaction Sheet supplied with the test kit. At the end of 15 days, record the final results. Typically, the results are unchanged after about two to five days of incubation.

Each test kit tests for the presence and count (bacterium/ml) of four (or five) types of viable bacteria.

A test kit that tests for four types of bacteria tests for:

- Sulfate reducing bacterial (BIO-SRB)
- Acid producing bacteria (RIO-APB)
- Aerobic bacteria (BIO-AERO)
- Anaerobic facultative bacteria (BIO-THIO)

A test kit that tests for five types of bacteria tests for:

- Sulfate reducing bacterial (BIO-SRB)
- Acid producing bacteria (BIO-APB)
- Aerobic bacteria (BIO-AERO)
- Iron-related (depositing) bacteria (BIO-IRB)
- Low-nutrient bacteria (BIO-LNB).

The presence and viability of these four (or five) types of bacteria are tested in each of the four (or five) colored strings of bottles in each tray. The bottles in each string contain a fast-acting nutrient specific to the bacterium tested. Some test kits give a quantitative indication of the viability of each bacterium from 10 to 10^5 bacterium/ml by the serial dilution of the sample and subsequent growth in each string; other test kits give a quantitative indication from 10 to 10^4 bacterium/ml.

SUPPORTING ANALYSES

Corrosion and other types of deposits on the pipe may be analyzed in the field using the test kit to assist in interpretation of MIC and other corrosion, or cathodic protection products. This kit can be used to qualitatively analyze for the presence of carbonate (CO_3^{+2}), sulfide (S^{-2}), ferrous iron (Fe^{+2}), ferric iron (Fe^{+3}), calcium (Ca^{+2}), and hydrogen (H^{+1} , pH) ions.

Collect a sample of soil, deposit, film, or liquid from the area of interest. Use only a clean knife or spatula provided with the test kit. The films or deposits may be from the steel surface, coating surface, interior of a corrosion pit, or the backside of the coating. In all cases, note the color and type of sample. Carefully transfer the sample to the test kit vial for testing. Follow the detailed procedure given in the test kit instruction sheets. For comparison purposes, obtain a reference sample taken at least 1 m from the previous collection site.

Record the results of the analysis on the Results Sheet provided with the kit or in a company designated format. Determine the likely type of deposit according to the characteristics shown below. A corrosion film

other than a carbonate, an oxide for example, may only show the presence of ferric or ferrous ion, but with a pH that is similar to that of the reference sample or lower. In addition, cathodic protection films may not necessarily show the presence of calcium or carbonate, but will have an elevated pH compared with the reference sample. For most types of soils, the pH is greater than about nine (9). An elevated pH is not usually associated with the presence of SRB.

Positive Result	SRB	Corrosion Film	Corrosion Oxide	CP Film
CO ₃ ⁻²		Yes		Yes
S ⁻²	Yes			
Fe ⁺²	Yes	Yes	Yes	
Fe ⁺³		Yes	Yes	
Ca ⁺²				Yes
pH				Elevated

METALLURGICAL INSPECTION

The form of the corrosion pits associated with MIC is reasonably distinctive. These features can be observed in the field with the unaided eye or a low power microscope.

After any films or products sampled above have been obtained from a corroded area, the remaining product should be removed using a clean spatula or knife, being careful not to scratch the metal. Clean any remaining material with a clean, dry, stiff brush, such as nylon-bristle brush. Do not use a metal brush if possible, because the metal bristles will mar the pit features. If not all of the product can be removed with this method, use a brass bristle brush in the longitudinal direction only. Dry the area with an air blast or an alcohol swab. A shiny metallic surface of the pit suggests the possibility of active corrosion. However, judgment must be used to differentiate this condition from one created by scraping the steel surface with a metallic object, such as the

knife or spatula use to clean the surface or obtain the sample product.

Examine the corroded area newly cleaned first visually with the unaided eye. Then use a low power magnifying lens at 5X to 50X power to examine the detail of the corrosion pits. MIC often has the following features:

- Large craters up to 2 or 3 inches (5 to 8 cm) in diameter or more
- Cup-type hemispherical pits on the pipe surface or in the craters
- Sometimes the craters or pits are surrounded by uncorroded metal
- Striations or contour lines in the pits or craters running parallel to longitudinal pipe axis (rolling direction)
- Sometimes tunnels can be seen at the ends of the craters also running parallel to the longitudinal axis of the pipe.

Some examples of these features are shown in other materials. The cupping action of the pits is a result of the local action of the bacteria. The striations follow the rolling direction of the steel made into the pipe and are believed to be a result of preferential attack of the steel microstructural components.

ACKNOWLEDGMENT

This chapter was written by K. C. Garrity and was edited by the AUCSC Curriculum Committee.

MIC OF 304 SS WELD

Under Tubercle Illustrated

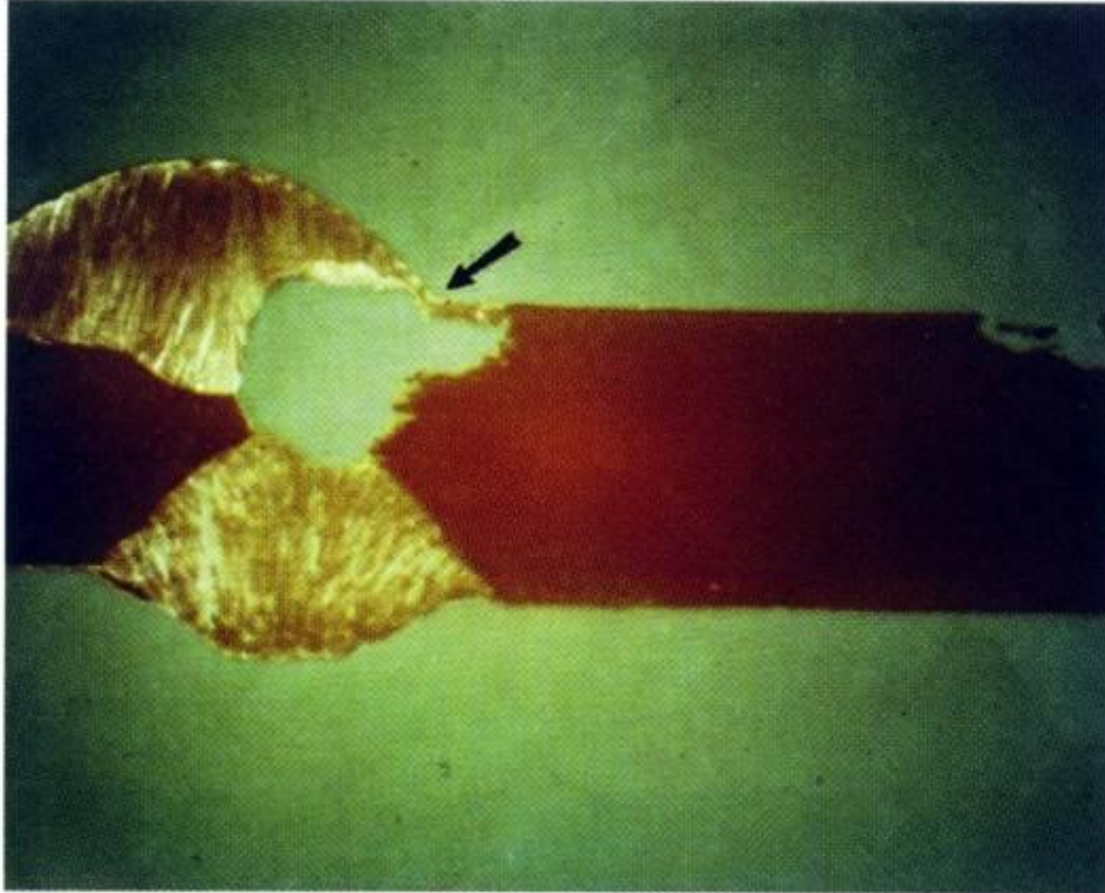

From Little, Wagner,
and Mansfeld

TUBERCLE BUILD-UP WITH IRON-RELATED BACTERIA

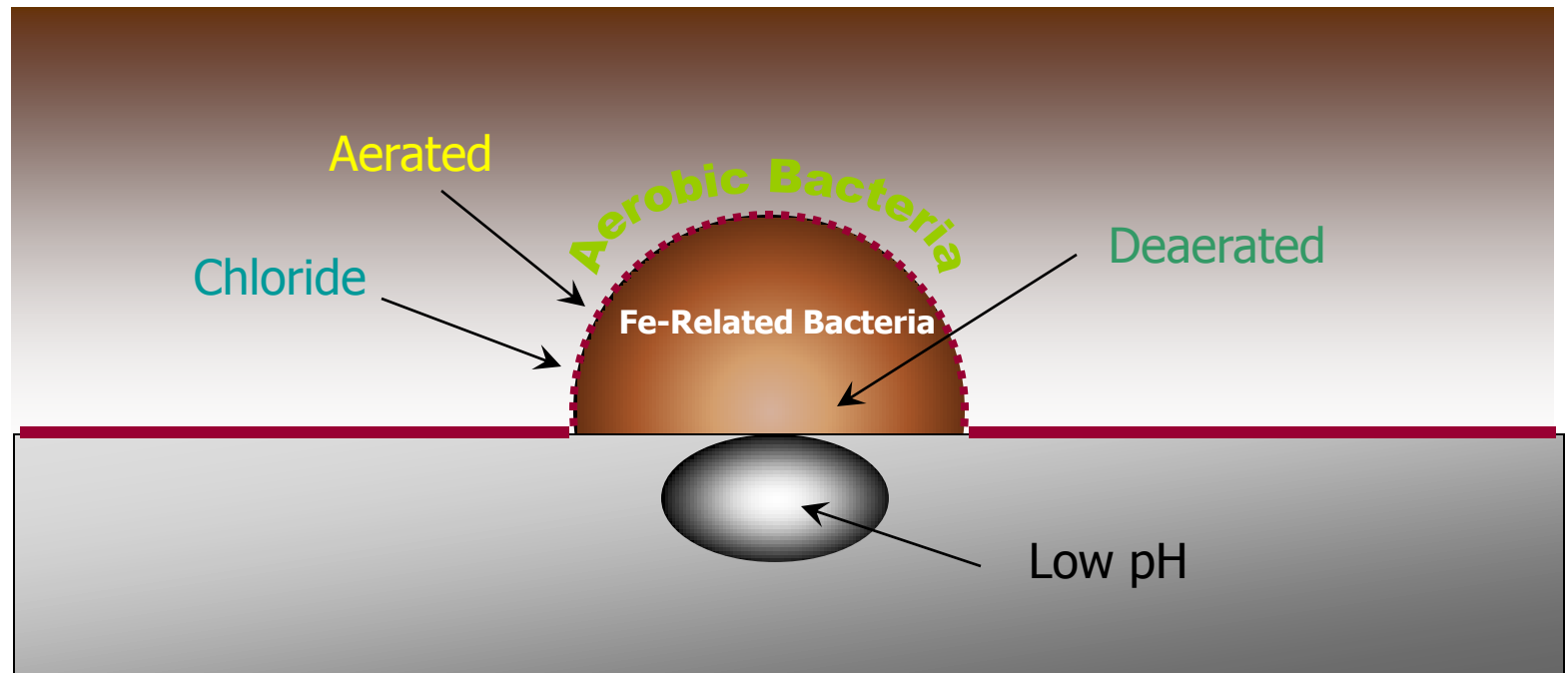

IRB Create a Differential Oxygen Corrosion Cell with Low pH Environment

METALLURGICAL

Pope and GRI

a. Striations in cupped pit bottoms



b. Corrosion in pit



c. Pit products in b. removed

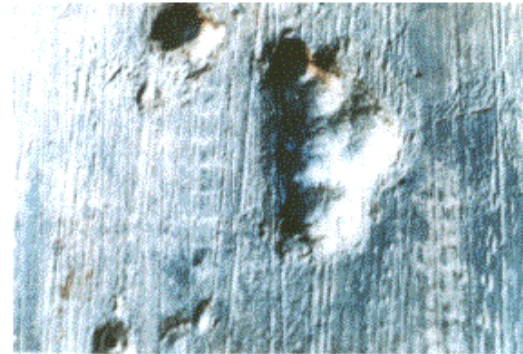

d. Brushed cupped pits in c.

MICROBIOLOGICAL

Aerobic and Anaerobic

- Aerobic Require O_2 and Nutrient
- Consume O_2 and Produce Organic Acids Corrosive to Steel
- Protection Requirements Less Well Defined
- Occur with Anaerobic Bacteria
- Form Complex Communities Dominated by Acid Producing Bacteria
- MIC a Result of Microbe Community, Not SRB Alone

MICROBIOLOGICAL COMMUNITY

Example APB and SRB

- Organic Nutrients Feed APB
- APB Products Nutrients for SRB
- SRB Fed by Organic Acids and Sulfate
- Produce more APB and SRB
- Chlorides with Acids (H^+) Lower pH and Corrode Steel

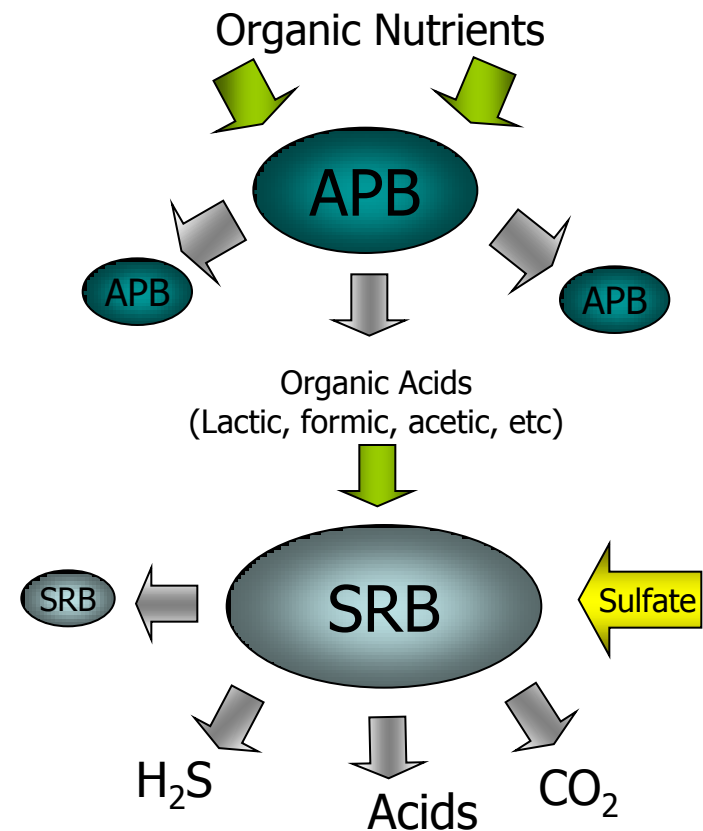

MICROBIOLOGICAL SRB Theory (Anaerobic)

- $8\text{H}_2\text{O} \rightleftharpoons 8\text{OH}^- + 8\text{H}^+$
- $4\text{Fe} \rightleftharpoons 4\text{Fe}^{+2} + 8\text{e}^-$ (A)
- $8\text{H}^+ + 8\text{e}^- \rightleftharpoons 8\text{H}$ (C)
- $\text{SO}_4^{-2} + 8\text{H} + \text{Bacteria} \rightleftharpoons$
 $\rightleftharpoons \text{S}^{-2} + 4\text{H}_2\text{O}$
- $\text{Fe}^{+2} + \text{S}^{-2} \rightleftharpoons \text{FeS}$ (A)
- $3\text{Fe}^{+2} + 6\text{OH}^- \rightleftharpoons 3\text{Fe}(\text{OH})_2$
(A)
- FeS Depolarizes
- Need Nutrient
 - Soil biomass
 - Coating adhesive
- Need No or Low O_2
 - Wet soil
 - Low areas
 - Crevices
- More Protection (Current)
Needed to Overcome
Effects

MIC TESTING

- Field Test Kits for Viable Bacteria
 - SRB, APB, anaerobic, aerobic, iron related
 - Bacteria count—10 to 10^5 (10^4) colonies/ml
- Test Soil or Surface Product
- Create Slurry
- Inoculate Culture Media Vials
- Compare After 2 - 5 Days, 15 Days

TEST KIT INTERPRETATION

- Presence of Bacteria Not Conclusive of MIC
- SRB Often Do Not Dominate
- Not Uncommon to Find All Tested Bacteria Present
- Interpret Indications with Caution
 - 1 to 3 bottles – may have problem
 - 1 to 5 bottles – possible problem

CULTURE TEST

Results

POSITIVE REACTIONS SHEET - MICKit™ III



1. Uninoculated (Negative)
2. Positive – Cloudy
3. Positive – Slime
4. Positive – Fungus



1. Uninoculated (Negative)
2. Positive – Cloudy

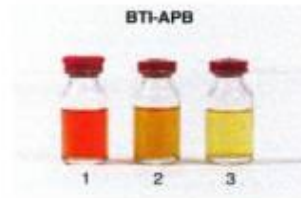

1. Uninoculated (Negative)
2. Positive – Orange color change
3. Positive – Yellow color change



1. Uninoculated (Negative)
2. Positive – Black color change
3. Positive – Slime formation on nail

Aerobic Bacteria Test

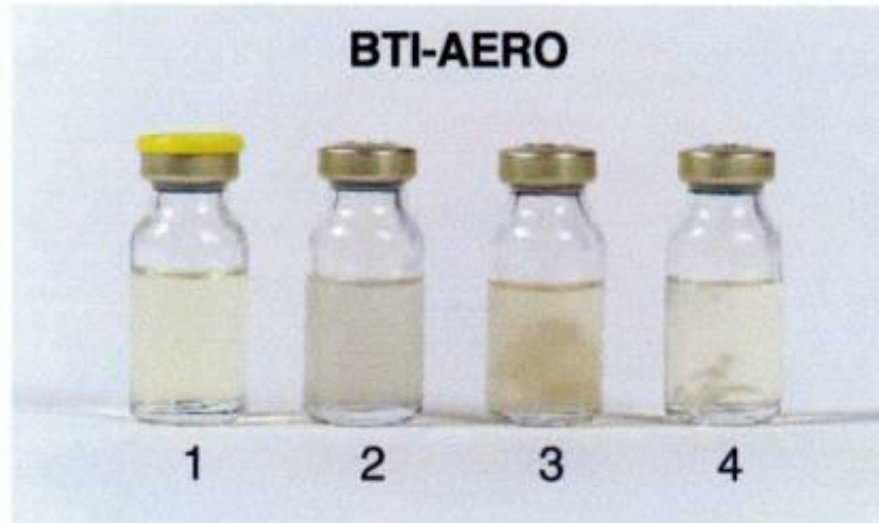

1. Uninoculated (Negative)
2. Positive – Cloudy
3. Positive – Slime
4. Positive – Fungus

APB Bacteria Test

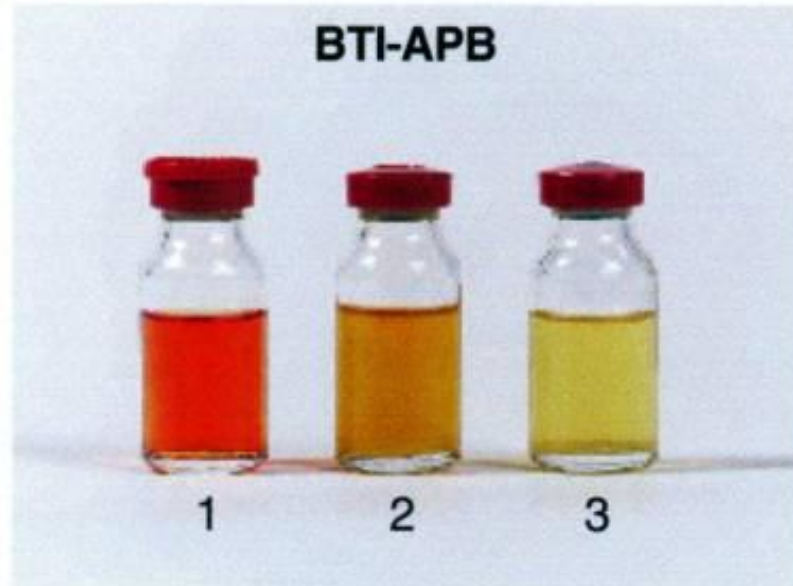

1. Uninoculated (Negative)
2. Positive – Orange color change
3. Positive – Yellow color change